

Appendix no. 1

Installation manual

SK4 container staircase

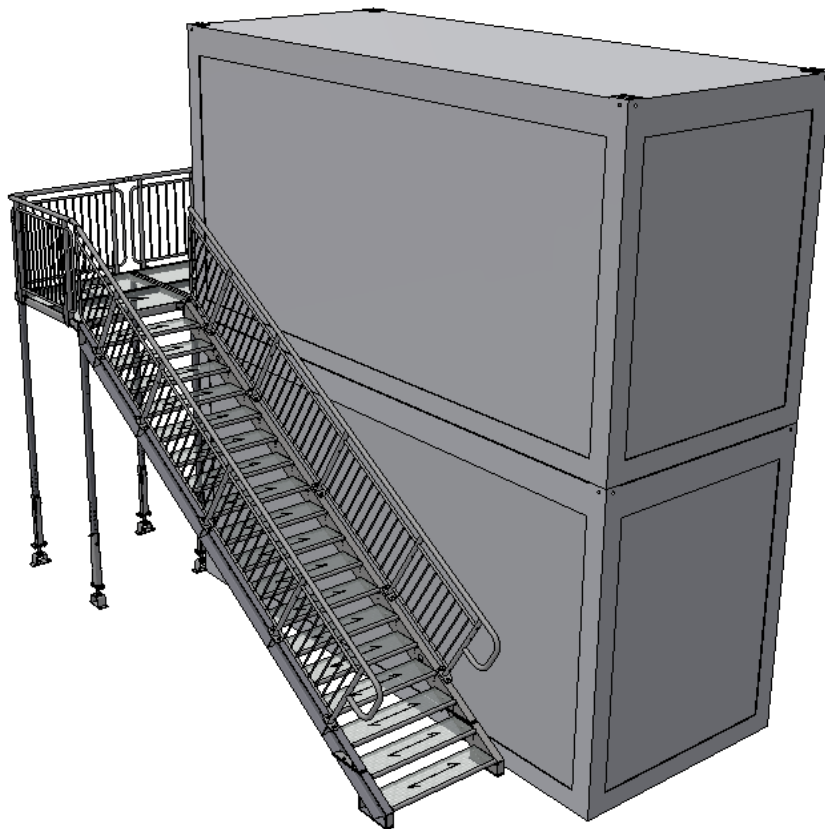

Piotr Abram

(Prepared by)

Robert Cieśla

(Verified by)

Miłosz Muzyka

(Approved by)

Edition 2.0, March 2022

Table of contents

1.	Installation manual	4
2.	Components of a container stair system	8
3.	Graphical list of SK4 system connectors.....	15
4.	List of SK4 system components.....	16
5.	List of tools needed for installation of container staircase	19
6.	Assembly operations for container staircase system components.....	20

List of revisions

No.	FULL NAME	DEPARTMENT	REVISION DATE	SCOPE OF CHANGES	COMMENTS
1					
2					
3					
4					
5					
6					
7					
8					
9					
10					
11					
12					
13					
14					
15					

1. Installation manual

The installation instructions are included as an appendix to TLC's technical and operating documentation for the container stair system.

The container staircase consist of elements according to the specifications attached to the delivery. The system features bolted connections. The system is supplied in the form of separate components such as landings, railings, steps, connectors, stairs and columns. The components are assembled in a specific order.

As a modular system, the container staircase can be freely (to the extent specified by the manufacturer) configured according to needs. The setting of the individual configurations should be in accordance with the DTR. The basic configurations of the container staircase are shown below.

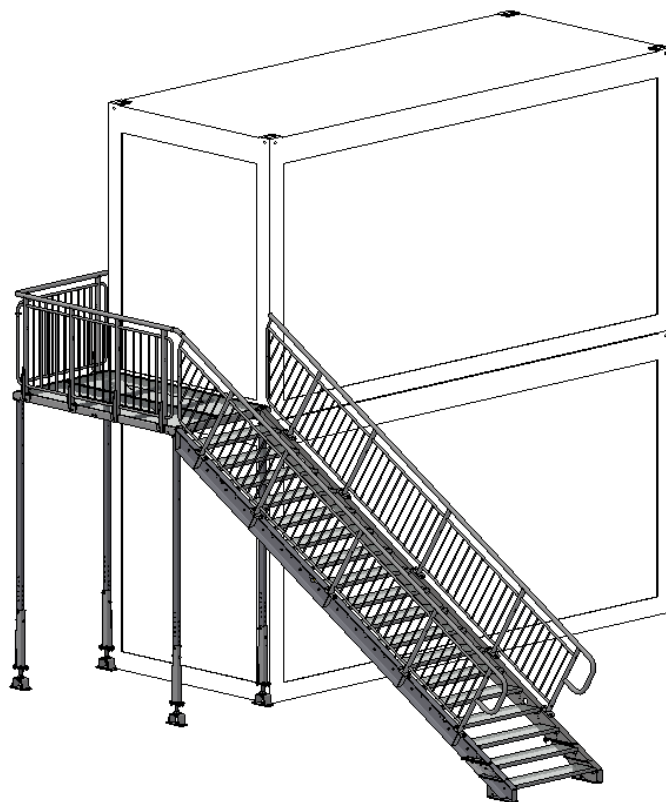

Rys. 1. option 1

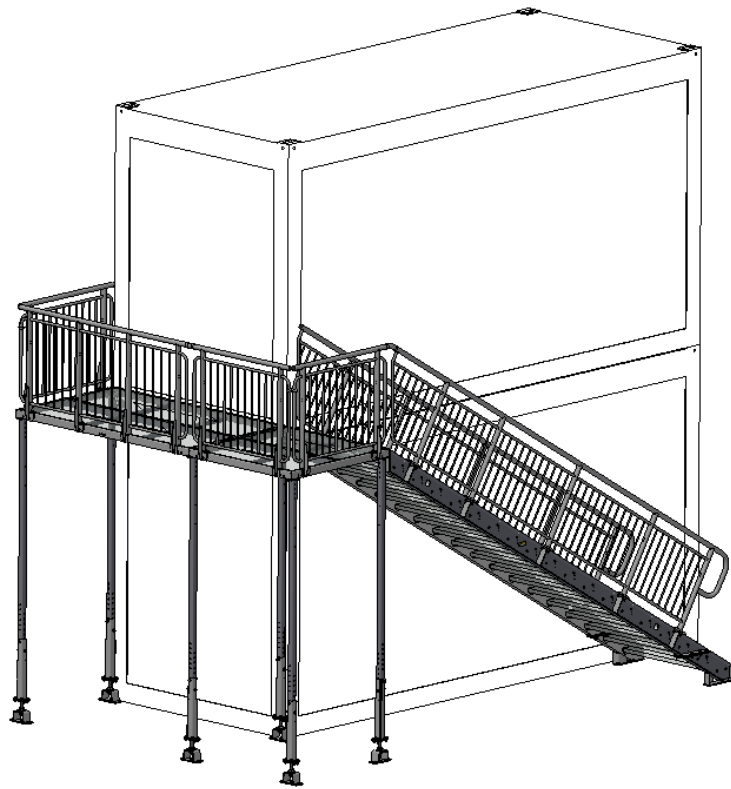

Rys. 2. option 3

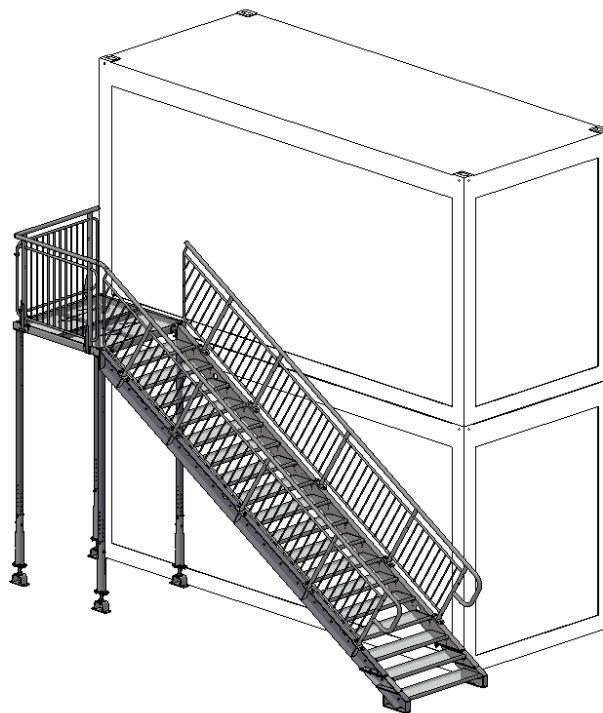

Rys. 3. option 4

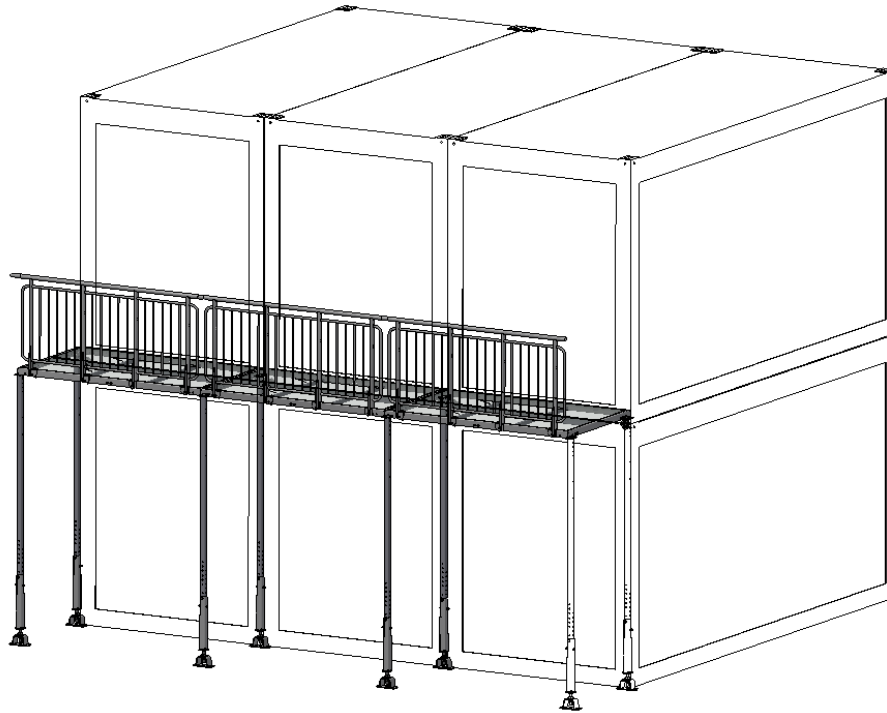

Rys. 4. Option 5

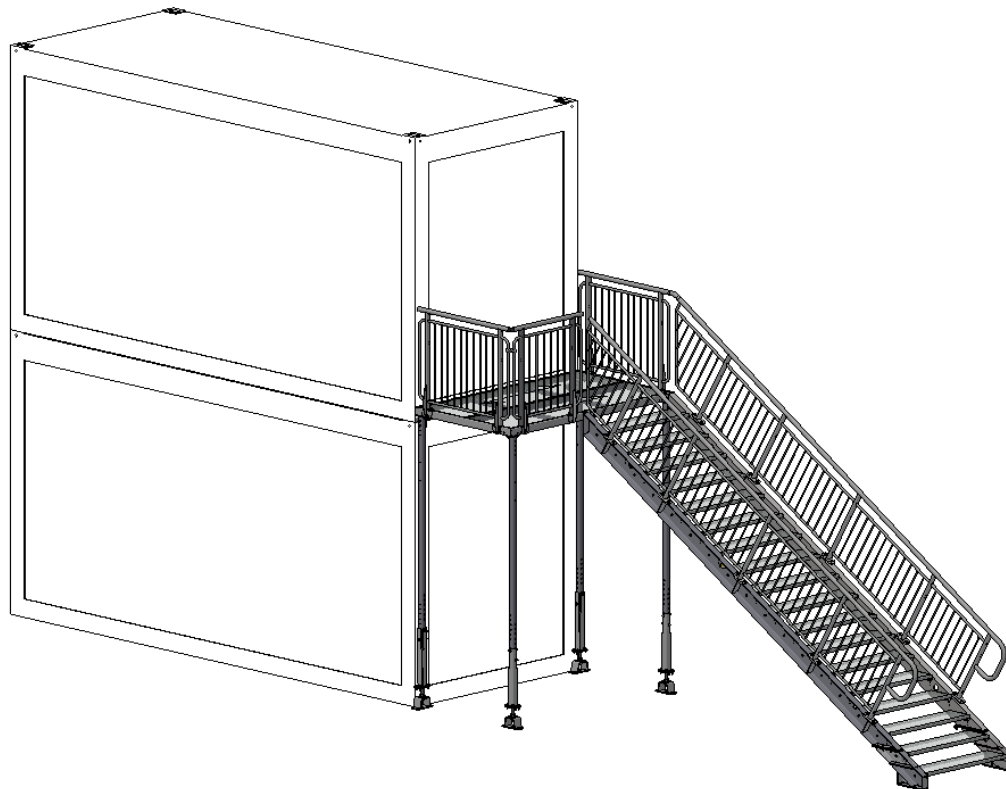

Rys. 5. Option 8

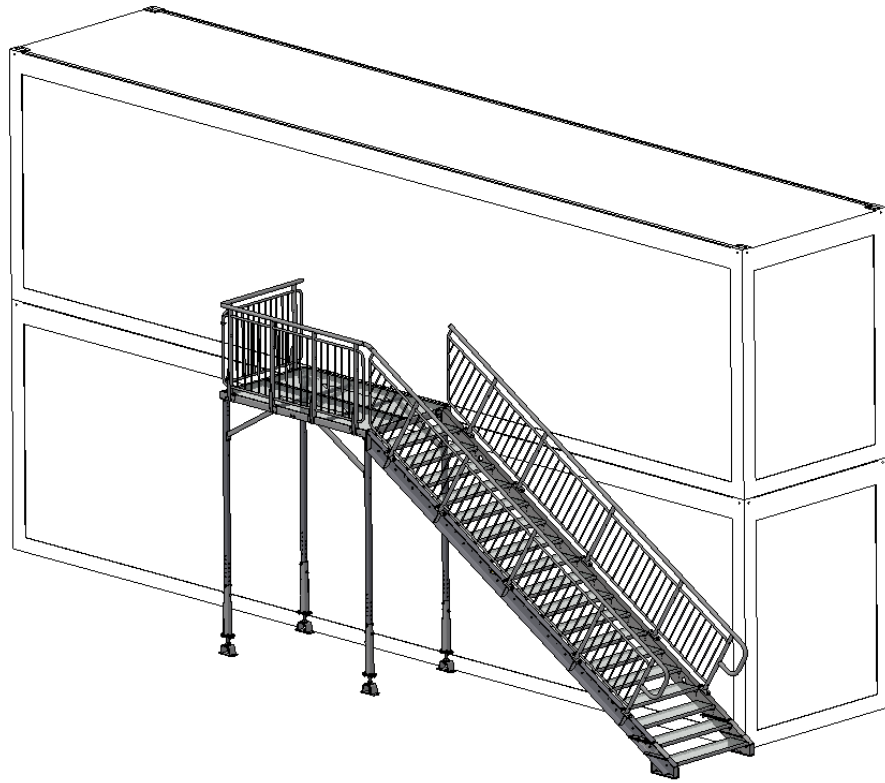

Rys. 6. option 10

2. Components of a container stair system.

The list of elements in Table 1 shows the components of the container staircase system and their quantities assembled depending on the configuration, and the type of system ordered by the customer (to be selected from the column designation, description of the element).

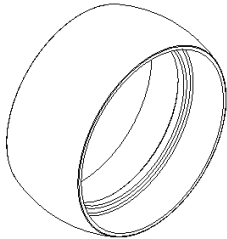
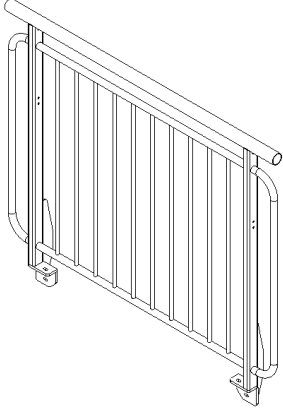
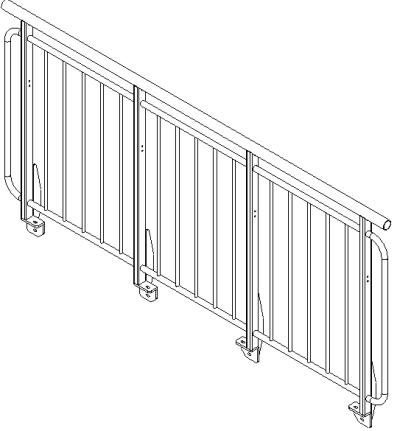
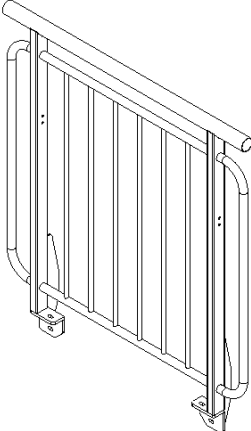
<p>BS-L3</p>  <p>Weight: 0.1 kg Dimensions 56 × 56 × 25 mm</p>	<p>SK4-BP11</p>  <p>Weight: 22.6 kg Dimensions: 1360 × 1180 × 98 mm</p>
<p>SK4-BP12</p>  <p>Weight: 39.6 kg Dimensions: 2360 × 1180 × 98 mm</p>	<p>SK4-BP13</p>  <p>Weight: 17.25 kg Dimensions: 1037 × 1180 × 98 mm</p>

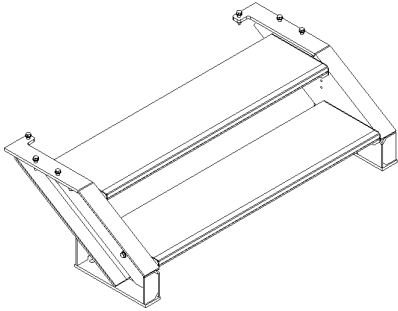
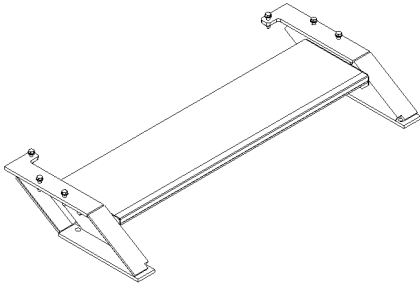
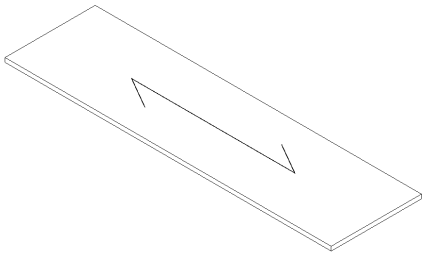
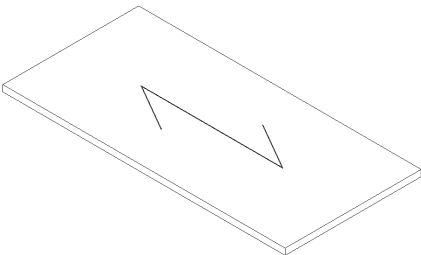
<p>SK4-BS9 Weight: 65.6 kg Dimensions 5808.43 × 958 × 89 mm</p>	
<p>SK4-FS6</p>  <p>Weight: 65.8 kg Dimensions: 1360 × 764.4 × 365 mm</p>	 <p>SK4-FS5 Weight: 5.7 kg Dimensions: 1360 × 643.8 × 160 mm</p>
<p>SK4-KR12</p>  <p>Weight: 28.6 kg Dimensions: 2350 × 650 × 30 mm</p>	<p>SK4-KR11</p>  <p>Weight: 16.4 kg Dimensions: 1350 × 650 × 30 mm</p>

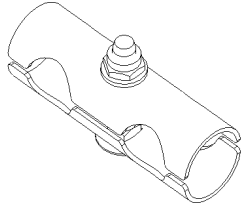
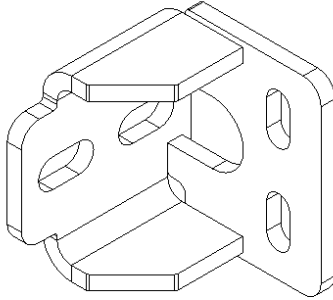
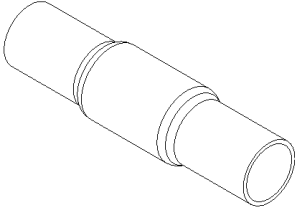
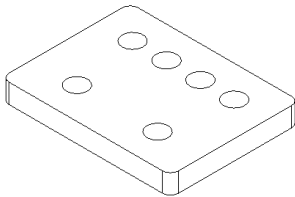
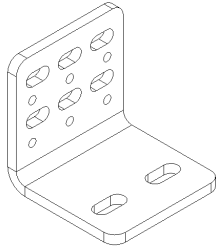
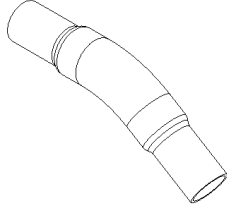
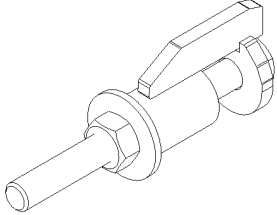
<p>SK4-L14</p>  <p>Weight: 0.2 kg Dimensions: 106.6 × 33.7 × 33.7 mm</p>	<p>SK4-L15</p>  <p>Weight: 1.2 kg Dimensions: 106 × 94 × 90 mm</p>
<p>SK4-L16</p>  <p>Weight: 0.5 kg Dimensions: 190 × 42.4 × 42.4 mm</p>	<p>SK4-L21</p>  <p>Weight: 0.72 kg Dimensions: 105 × 80 × 12 mm</p>
<p>SK4-L22</p>  <p>Weight: 1 kg Dimensions: 103 × 100 × 100 mm</p>	<p>SK4-L24</p>  <p>Weight: 0.7 kg Dimensions: 245.37 × 107.9 × 48.3 mm</p>
<p>SK4-L8</p>  <p>Weight: 0.2 kg</p>	

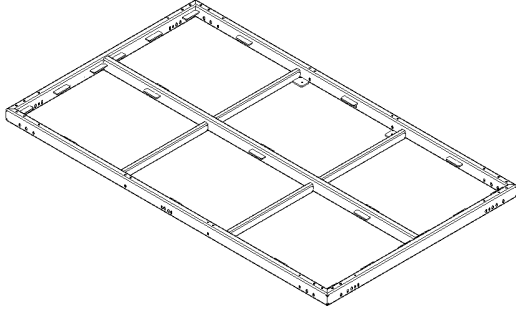
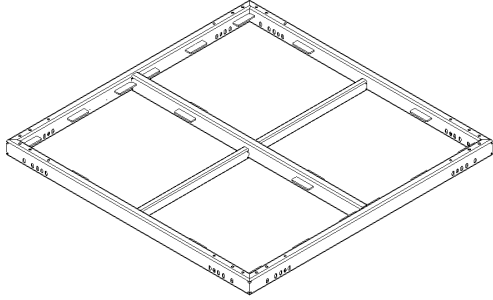
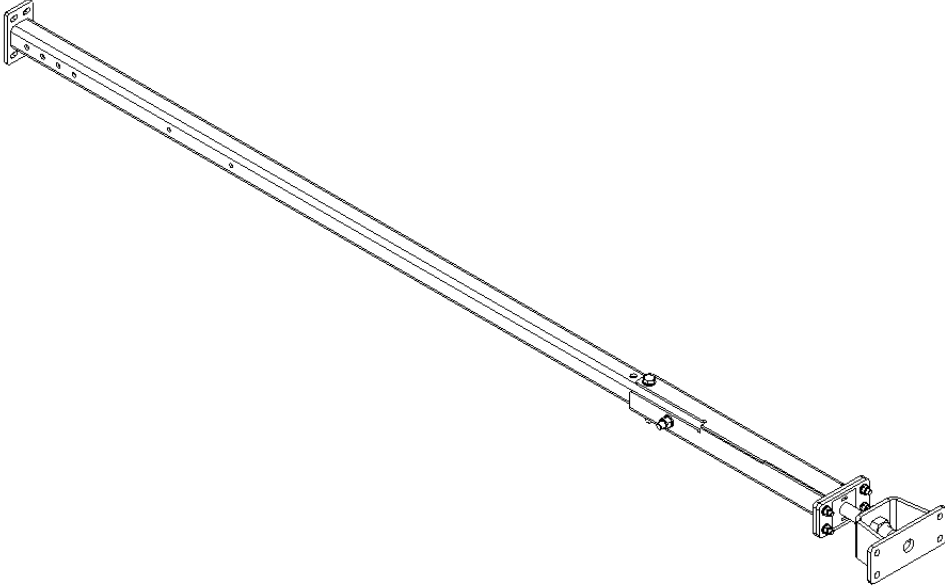
<p>Dimensions: 106 × 38 × 30 mm</p>	
<p>SK4-PD11</p>  <p>Weight: 78.8 kg Dimensions 2440 × 1440 × 80 mm</p>	<p>SK4-PD12</p>  <p>Weight: 53 kg Dimensions: 1440 × 1440 × 80 mm</p>
<p>SK4-PS9</p>  <p>Weight: 38.8 kg Dimensions: 2832.4 × 240 × 140 mm</p>	

SK4-SB1



Weight: 455.7 kg
 Dimensions: 5515.5 × 1360 × 200 mm

SK4-X3

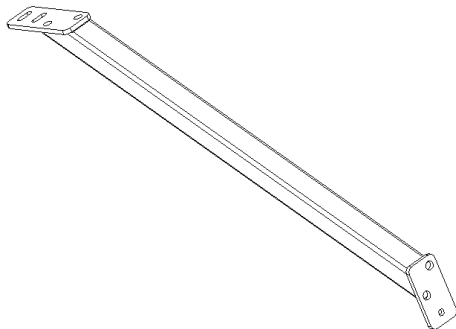

Weight: 4.7 kg
 Dimensions: 1019.4 × 94 × 60 mm

SK5-L16

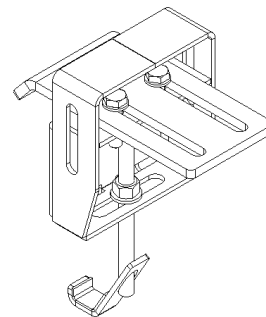

Weight: 2.4 kg
 Dimensions: 257 × 192x128 mm

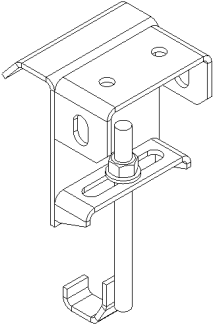
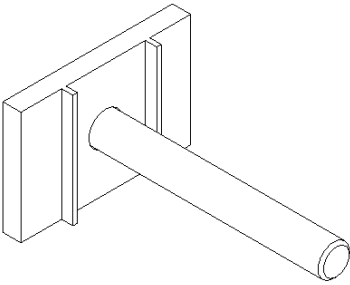
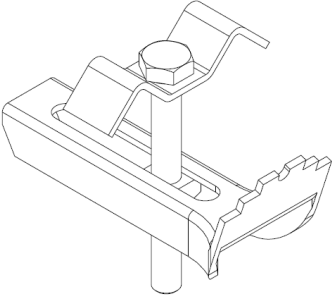
<p>SK5-L2</p>  <p>Weight: 1.1 kg Dimensions: 221 × 101 × 100 mm</p>	<p>P-SK5-ZW-01</p>  <p>Weight: 0.4 kg Dimensions: 118 × 75 × 50 mm</p>
<p>M-KR-UK-G01-34 × 38</p>  <p>Weight: 0.1 kg Dimensions: 50 × 100 × 70 mm</p>	

Tab 1. Components of a container staircase system.

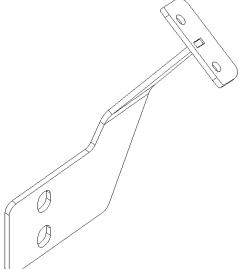
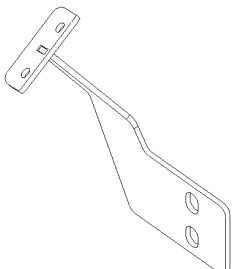
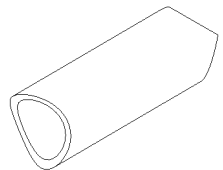
<p>SK4-SP1</p>  <p>Weight: 12.8 kg Dimensions: 5831.4 × 242.4 × 42.4 mm</p>	
<p>SK4-L17</p>  <p>Weight: 0.2 kg Dimensions: 123.4 × 123.3 × 50</p>	<p>SK4-L18</p>  <p>Weight: 0.2 kg Dimensions: 123.4 × 123.3 × 50</p>
<p>SK4-L20</p>  <p>Weight: 0.11 kg Dimensions: 74,7 × 26,9 mm</p>	

Tab 2. Component parts of an add-on to a container stair system for an additional handrail.

3. Graphical list of SK4 system connectors

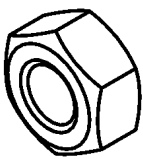
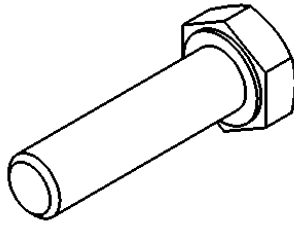
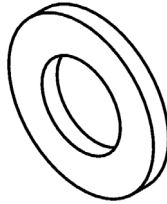
 <p>M12 M10</p>	 <p>M10 × 110 M12 × 50 M10 × 90 M12 × 80 M10 × 70 M12 × 100 M10 × 35 M12 × 120 M12x40</p>	 <p>W12 W10</p>
--	--	--

4. List of SK4 system components

The list of elements in Table 2 shows the components of the container staircase system and their quantities assembled depending on the configuration, and the type of system ordered by the customer (to be selected from the column designation, description of the element).

index	var1			var3			var4			var5			var8			var10		
	2.8	2.9	3.1	2.8	2.9	3.1	2.8	2.9	3.1	2.8	2.9	3.1	2.8	2.9	3.1	2.8	2.9	3.1
BS-L3	2	2	2	4	4	4	2	2	2	2	2	2	2	2	2	2	2	2
M-KR-UK-G01-34 × 38	12	12	12	20	20	20	8	8	8	12	12	12	12	12	12	12	12	12
P-SK5-ZW-01	2	2	0	2	2	0	1	1	0	2	2	0	2	2	0			
SK4-BP11	1	1	1	3	3	3	2	2	2				2	2	2	1	1	1
SK4-BP12	1	1	1	1	1	1				1	1	1				1	1	1
SK4-BP13													1	1	1			
SK4-BS9	2	2	2	2	2	2	2	2	2				2	2	2	2	2	2
SK4-EZ-V1	1	1	1															
SK4-EZ-V10																1	1	1
SK4-EZ-V3				1	1	1												
SK4-EZ-V4							1	1	1									
SK4-EZ-V5										1	1	1						
SK4-EZ-V8													1	1	1			
SK4-FS5	0	1	0	0	1	0	0	1	0				0	1	0	0	1	0
SK4-FS6	0	0	1	0	0	1	0	0	1				0	0	1	0	0	1
SK4-KR11				2	2	2	2	2	2									
SK4-KR12	2	2	2	2	2	2				2	2	2	2	2	2	2	2	2
SK4-L14	1	1	1	2	2	2	1	1	1				1	1	1	1	1	1
SK4-L15	2	2	0	2	2	0	1	1	0	2	2	0	2	2	0			
SK4-L16				1	1	1				1	1	1						
SK4-L21							1	1	1							2	2	2
SK4-L22	0	0	2	0	0	2	0	0	1	0	0	2	0	0	2			
SK4-L24	1	1	1	1	1	1	1	1	1				1	1	1	1	1	1
SK4-L8	0	0	2	0	0	2	0	0	1	0	0	2	0	0	2			
SK4-PD11	1	1	1	1	1	1				1	1	1				1	1	1
SK4-PD12				1	1	1	1	1	1									
SK4-PS9	4	4	4	6	6	6	4	4	4	2*	2*	2*	4	4	4	4	4	4
SK4-SB1	1	1	1	1	1	1	1	1	1				1	1	1			
SK4-X3																4	4	4
SK5-L16																2	2	2
SK5-L2							1	1	1									

*match to the order

Tab 3. Contents of variants depending on height

Name	index	quantity
Connectors Var1	SK4-EZ-V1	
Bolt ISO 4014 8-ZO – M12 × 100	M-Z-S-SZ-12x100-8-ZO	4
Bolt ISO 4014 8-ZO – M12 × 80	M-Z-S-SZ-12x80-8-ZO	4
Bolt ISO 4017 8-ZO – M12 × 50	M-Z-S-SZ-12x50-8-ZO	20
Bolt ISO 4014 8-ZO – M10 × 110	M-Z-S-SZ-10 × 110-8-ZO	14
Bolt ISO 4014 8-ZO – M10 × 70	M-Z-S-SZ-10 × 70-8-ZO	6
ISO 7089 washer 8-ZO-12 – 200 HV	M-Z-P-Z-12-8-ZO	56
ISO 7089 washer 8-ZO-10 – 200 HV	M-Z-P-Z-10-8-ZO	40
Nut ISO 4032 8-ZO – M12	M-Z-N-SZ-12-8-ZO	28
Nut ISO 4032 8-ZO – M10	M-Z-N-SZ-10-8-ZO	20
Round inner plug "48.3	M-PVC-ZW-48,3	4

Name	index	quantity
Connectors Var3	SK4-EZ-V3	
Bolt ISO 4014 8-ZO – M12 × 110	M-Z-S-SZ-12x110-8-ZO	2
Bolt ISO 4014 8-ZO – M12 × 100	M-Z-S-SZ-12x100-8-ZO	4
Bolt ISO 4014 8-ZO – M12 × 80	M-Z-S-SZ-12x80-8-ZO	4
Bolt ISO 4017 8-ZO – M12 × 50	M-Z-S-SZ-12x50-8-ZO	20
Bolt ISO 4014 8-ZO – M10 × 110	M-Z-S-SZ-10 × 110-8-ZO	22
Bolt ISO 4014 8-ZO – M10 × 70	M-Z-S-SZ-10 × 70-8-ZO	10
ISO 7089 washer 8-ZO-12 – 200 HV	M-Z-P-Z-12-8-ZO	60
ISO 7089 washer 8-ZO-10 – 200 HV	M-Z-P-Z-10-8-ZO	64
Nut ISO 4032 8-ZO – M12	M-Z-N-SZ-12-8-ZO	30
Nut ISO 4032 8-ZO – M10	M-Z-N-SZ-10-8-ZO	32
Round inner plug "48.3	M-PVC-ZW-48,3	6

Name	index	quantity
Connectors Var4	SK4-EZ-V4	
Bolt ISO 4014 8-ZO – M12 × 100	M-Z-S-SZ-12x100-8-ZO	4
Bolt ISO 4014 8-ZO – M12 × 80	M-Z-S-SZ-12x80-8-ZO	4
Bolt ISO 4017 8-ZO – M12 × 50	M-Z-S-SZ-12x50-8-ZO	21
Bolt ISO 4014 8-ZO – M10 × 110	M-Z-S-SZ-10 × 110-8-ZO	12
Bolt ISO 4014 8-ZO – M10 × 70	M-Z-S-SZ-10 × 70-8-ZO	4
ISO 7089 washer 8-ZO-12 – 200 HV	M-Z-P-Z-12-8-ZO	58
ISO 7089 washer 8-ZO-10 – 200 HV	M-Z-P-Z-10-8-ZO	32
Nut ISO 4032 8-ZO – M12	M-Z-N-SZ-12-8-ZO	29
Nut ISO 4032 8-ZO – M10	M-Z-N-SZ-10-8-ZO	16
Round inner plug "48.3	M-PVC-ZW-48,3	4





Name	index	quantity
Connectors Var5	SK4-EZ-V5	
Bolt ISO 4014 8-ZO – M12 × 110	M-Z-S-SZ-12x110-8-ZO	2
Bolt ISO 4014 8-ZO – M12 × 90	M-Z-S-SZ-12x90-8-ZO	4
Bolt ISO 4014 8-ZO – M10 × 110	M-Z-S-SZ-10 × 110-8-ZO	10
Bolt ISO 4014 8-ZO – M10 × 70	M-Z-S-SZ-10 × 70-8-ZO	4
ISO 7089 washer 8-ZO-12 – 200 HV	M-Z-P-Z-12-8-ZO	12
ISO 7089 washer 8-ZO-10 – 200 HV	M-Z-P-Z-10-8-ZO	28
Nut ISO 4032 8-ZO – M12	M-Z-N-SZ-12-8-ZO	6
Nut ISO 4032 8-ZO – M10	M-Z-N-SZ-10-8-ZO	14

Name	index	quantity
Connectors Var8	SK4-EZ-V8	
Bolt ISO 4014 8-ZO – M12 × 100	M-Z-S-SZ-12x100-8-ZO	4
Bolt ISO 4014 8-ZO – M12 × 80	M-Z-S-SZ-12x80-8-ZO	4
Bolt ISO 4017 8-ZO – M12 × 50	M-Z-S-SZ-12x50-8-ZO	20
Bolt ISO 4014 8-ZO – M10 × 110	M-Z-S-SZ-10 × 110-8-ZO	14
Bolt ISO 4014 8-ZO – M10 × 70	M-Z-S-SZ-10 × 70-8-ZO	6
ISO 7089 washer 8-ZO-12 – 200 HV	M-Z-P-Z-12-8-ZO	56
ISO 7089 washer 8-ZO-10 – 200 HV	M-Z-P-Z-10-8-ZO	40
Nut ISO 4032 8-ZO – M12	M-Z-N-SZ-12-8-ZO	28
Nut ISO 4032 8-ZO – M10	M-Z-N-SZ-10-8-ZO	20
Round inner plug "48.3	M-PVC-ZW-48,3	6

Name	index	quantity
Connectors Var10	SK4-EZ-V10	
Bolt ISO 4014 8-ZO – M12 × 120	M-Z-S-SZ-12x120-8-ZO	8
Bolt ISO 4014 8-ZO – M12 × 100	M-Z-S-SZ-12x100-8-ZO	4
Bolt ISO 4014 8-ZO – M12 × 80	M-Z-S-SZ-12x80-8-ZO	4
Bolt ISO 4017 8-ZO – M12 × 50	M-Z-S-SZ-12x50-8-ZO	22
Bolt ISO 4014 8-ZO – M10 × 110	M-Z-S-SZ-10 × 110-8-ZO	6
Bolt ISO 4014 8-ZO – M10 × 90	M-Z-S-SZ-10 × 90-8-ZO	4
Bolt ISO 4014 8-ZO – M10 × 70	M-Z-S-SZ-10 × 70-8-ZO	6
Bolt ISO 4017 8-ZO – M10 × 40	M-Z-S-SZ-10 × 40-8-ZO	4
ISO 7089 washer 8-ZO-12 – 200 HV	M-Z-P-Z-12-8-ZO	76
ISO 7089 washer 8-ZO-10 – 200 HV	M-Z-P-Z-10-8-ZO	40
Nut ISO 4032 8-ZO – M12	M-Z-N-SZ-12-8-ZO	38
Nut ISO 4032 8-ZO – M10	M-Z-N-SZ-10-8-ZO	20
Round inner plug "48.3	M-PVC-ZW-48,3	4

Tab 4. Contents of connector sets

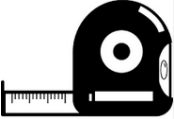
5. List of tools needed for installation of container staircase

	<p>Wrenches: 22,19,18,17,16,13,10</p>
	<p>Spirit level</p>
	<p>Measuring tape</p>
	<p>Lifting device with a lifting capacity of min. 1 t</p>

Tab 5. List of tools

6. Assembly operations for container staircase system components

The assembly instructions show how to assemble the individual components of the container staircase system.

6.1. Before installation, the components must be checked for completeness in accordance with the list for the respective variant and container height. Plan the location of the platform and staircase.

6.2. Possibility of installing variant 1

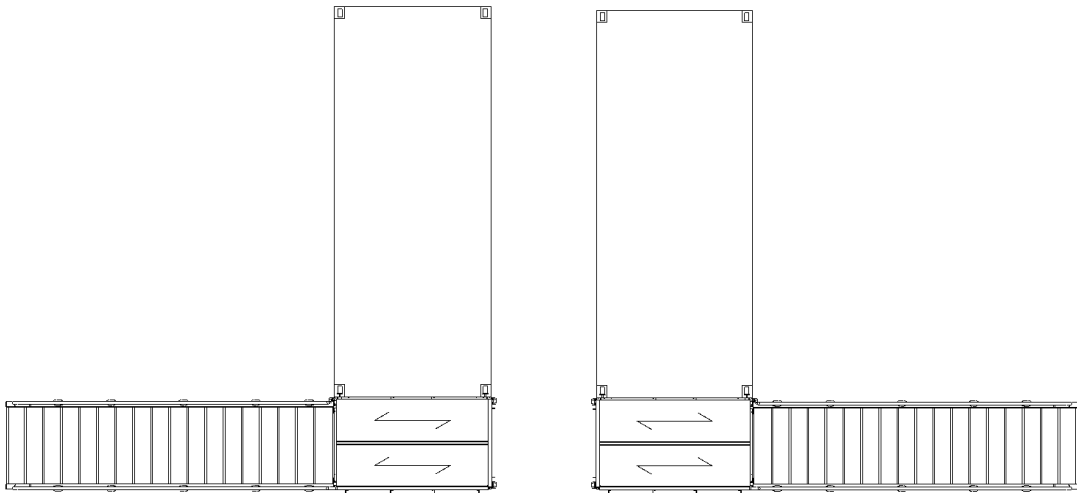

6.2. Possibility of installing variant 3

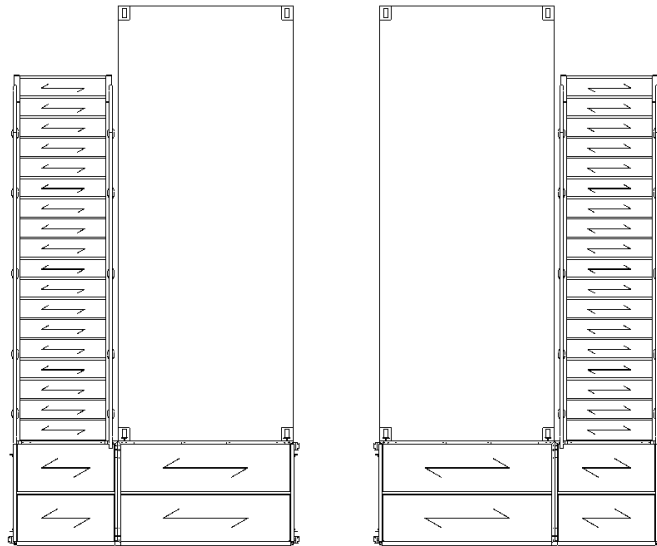

6.3. Possibility of installing variant 4

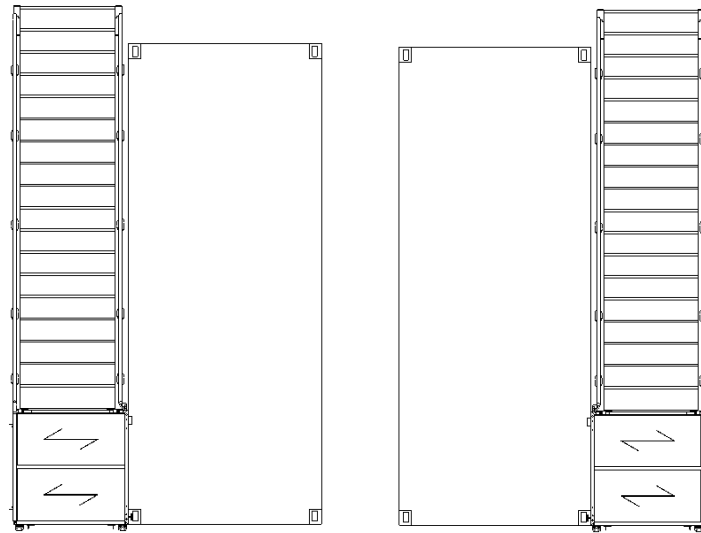

6.4. Possibility of installing variant 5

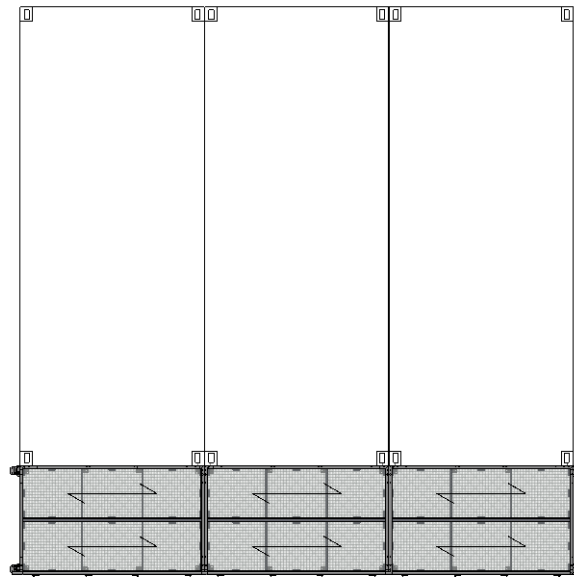

NOTE: Option 5 is in addition to options 1, 3, 8 and cannot be used on its own. Select supports individually to the number of platforms

6.5. Possibility of installing variant 8

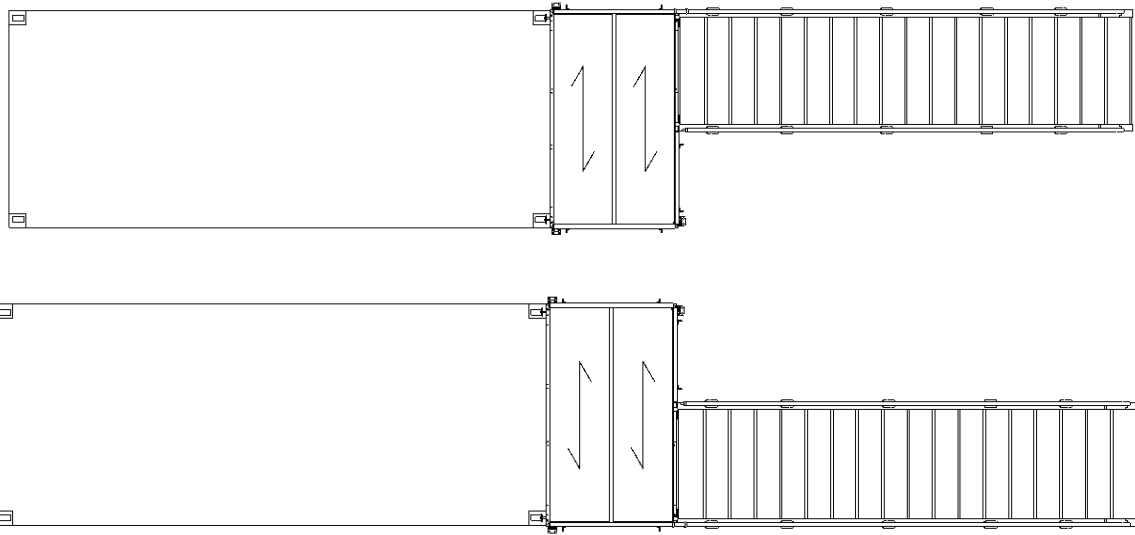

6.6. Possibility of installing variant 10

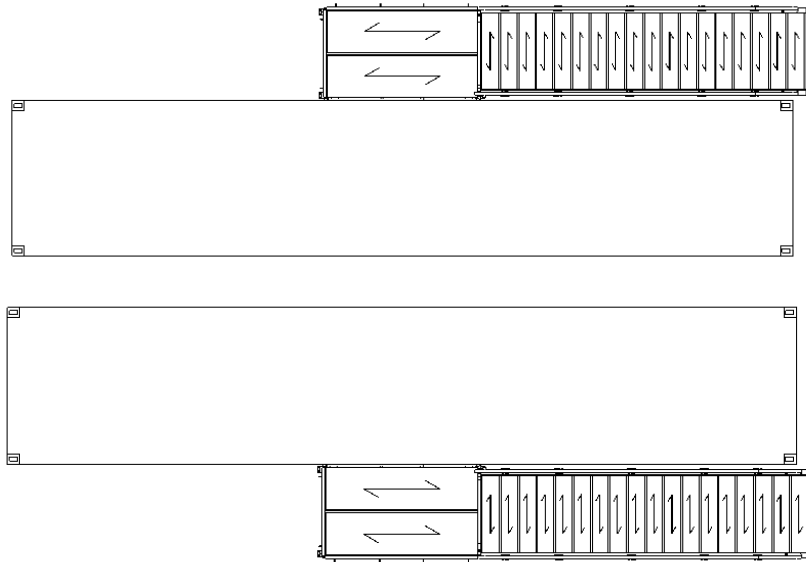

6.7. Installation of platform on supports. Seat the platform frame on the columns, fasten with a bolt, washer, nut set. Install the infill in the form of gratings using grating brackets.

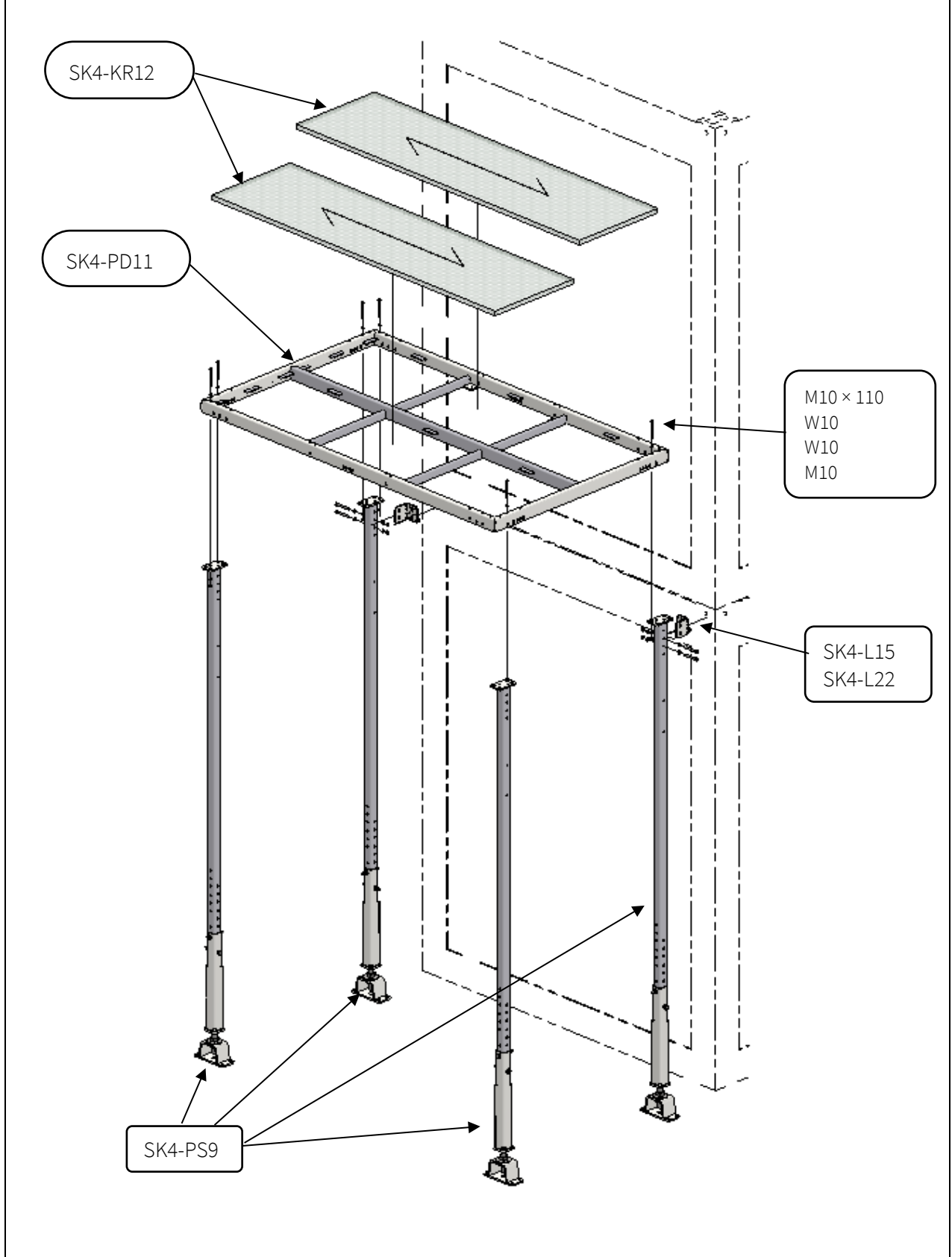

6.8. Mounting to container using SK4-L22 and SK4-L8 connectors

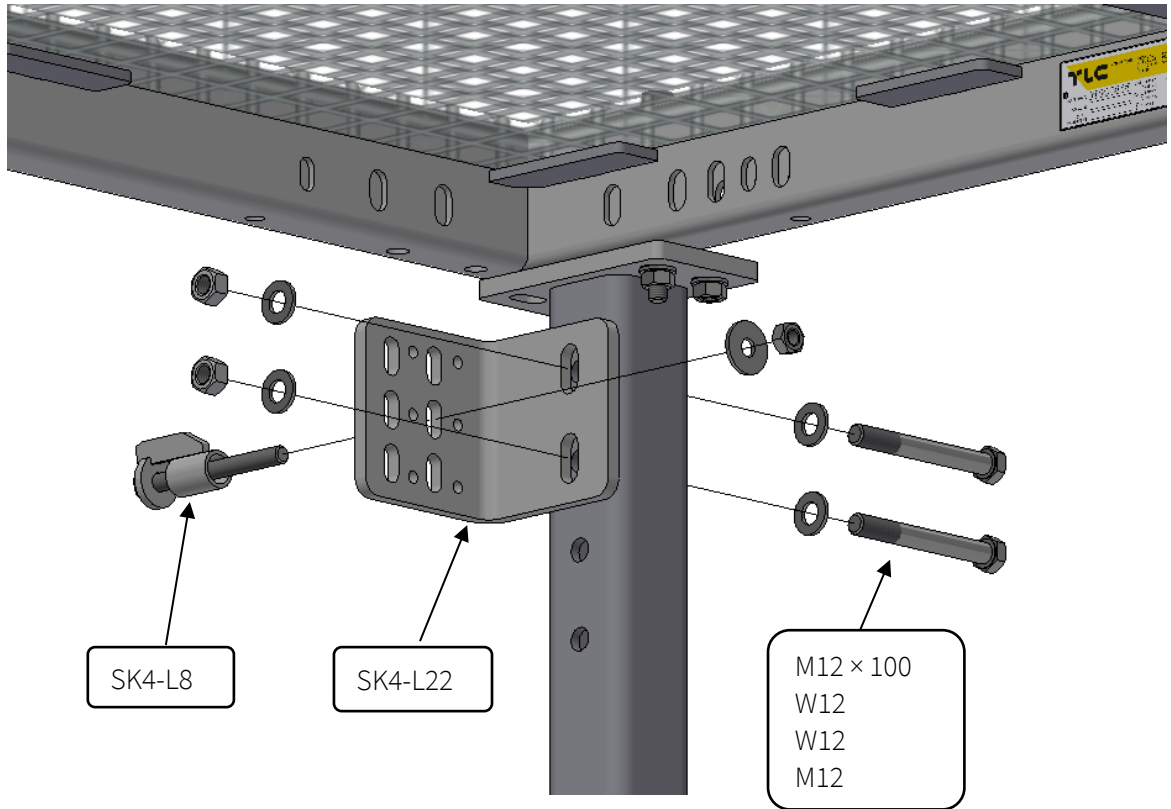

6.9. Mounting to the container using SK4-L15 and P-SK5-ZW-01 connectors

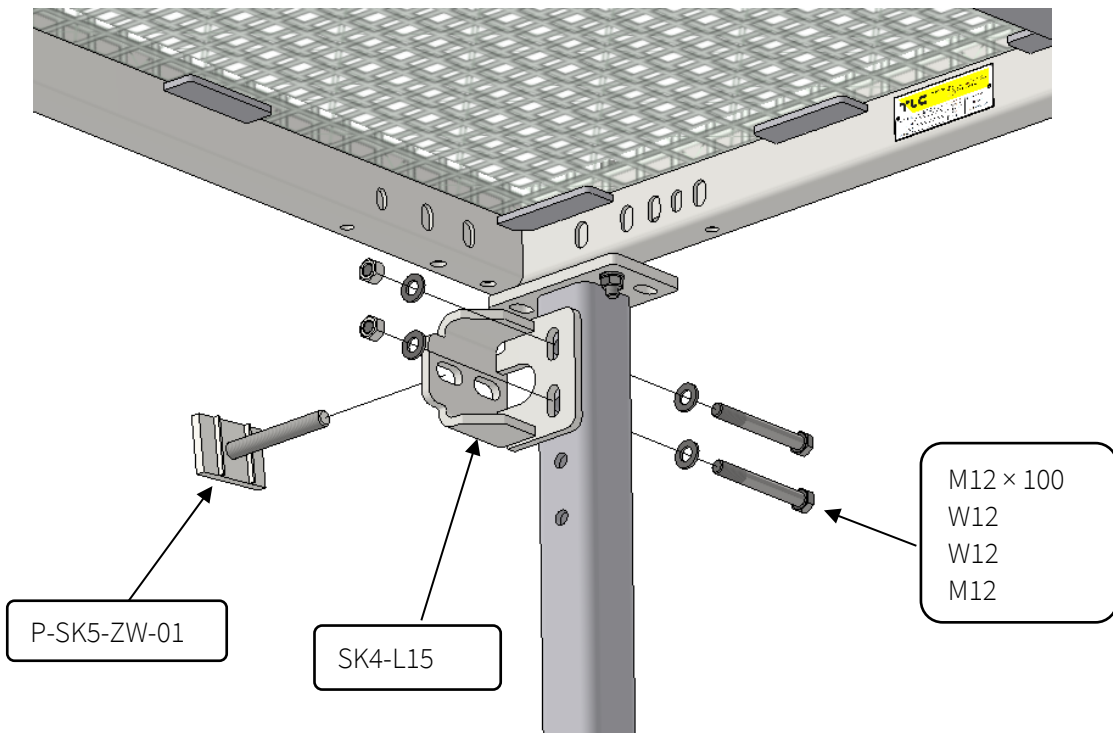

6.10. Set the frame of the next platform on the columns according to the diagram below. Tighten with bolt, washer, nut set. Install the gratings using the grating brackets.

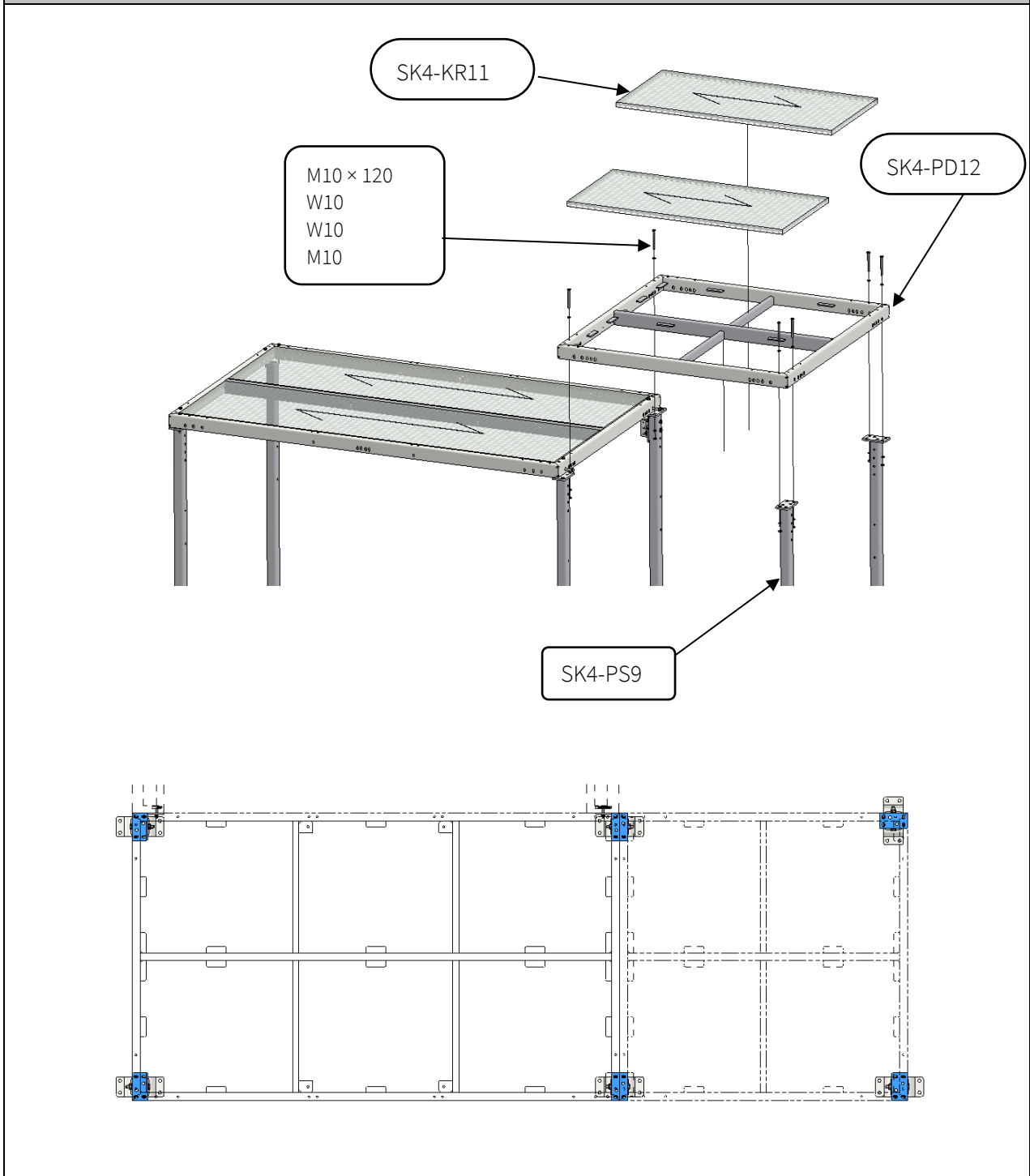

6.11. Screw the stair extension together using the bolt, washer and nut set

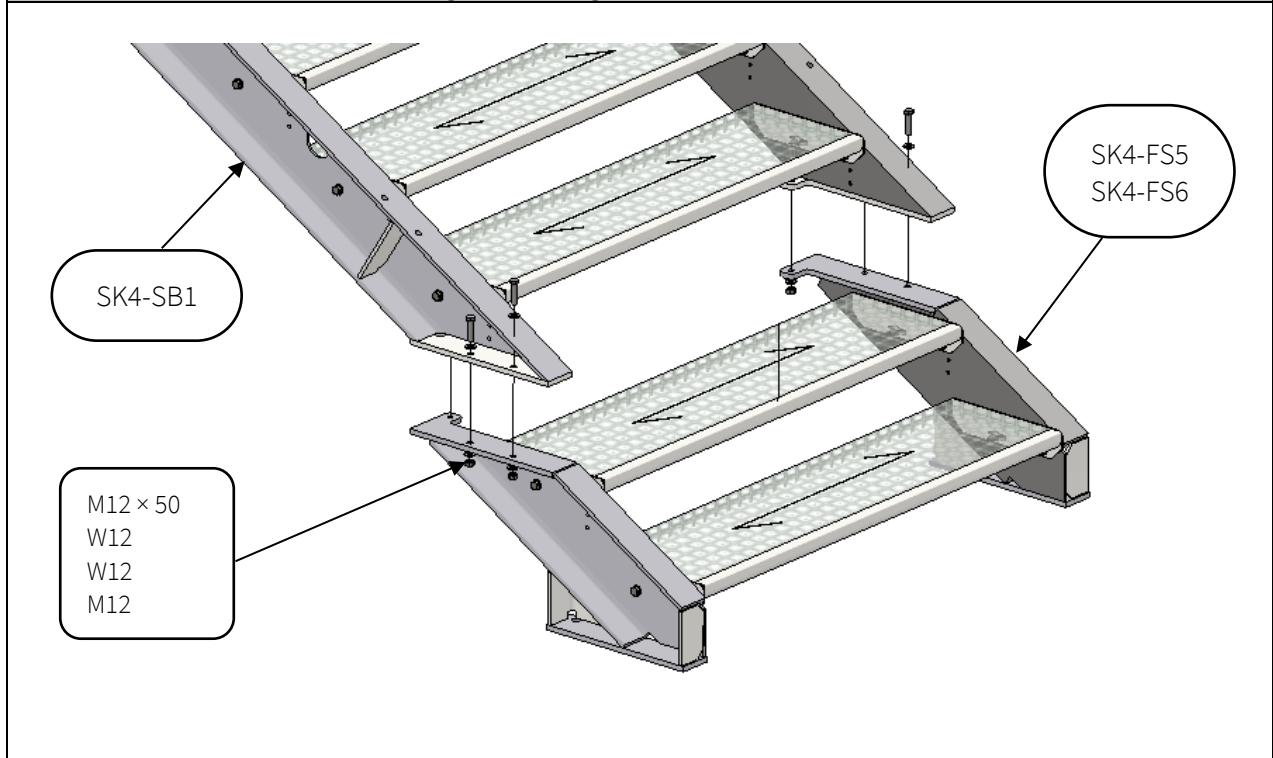

6.12. Hang the staircase on the platform and screw it down with the bolt washer nut set



6.13. Mounting the handrail to the staircase, the handrail should be bolted with a bolt washer nut set.

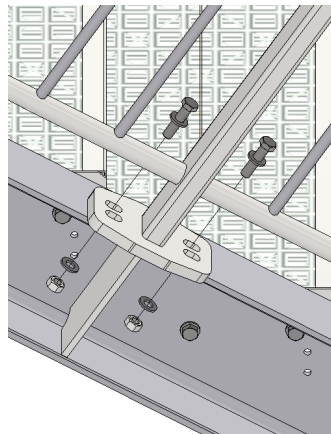
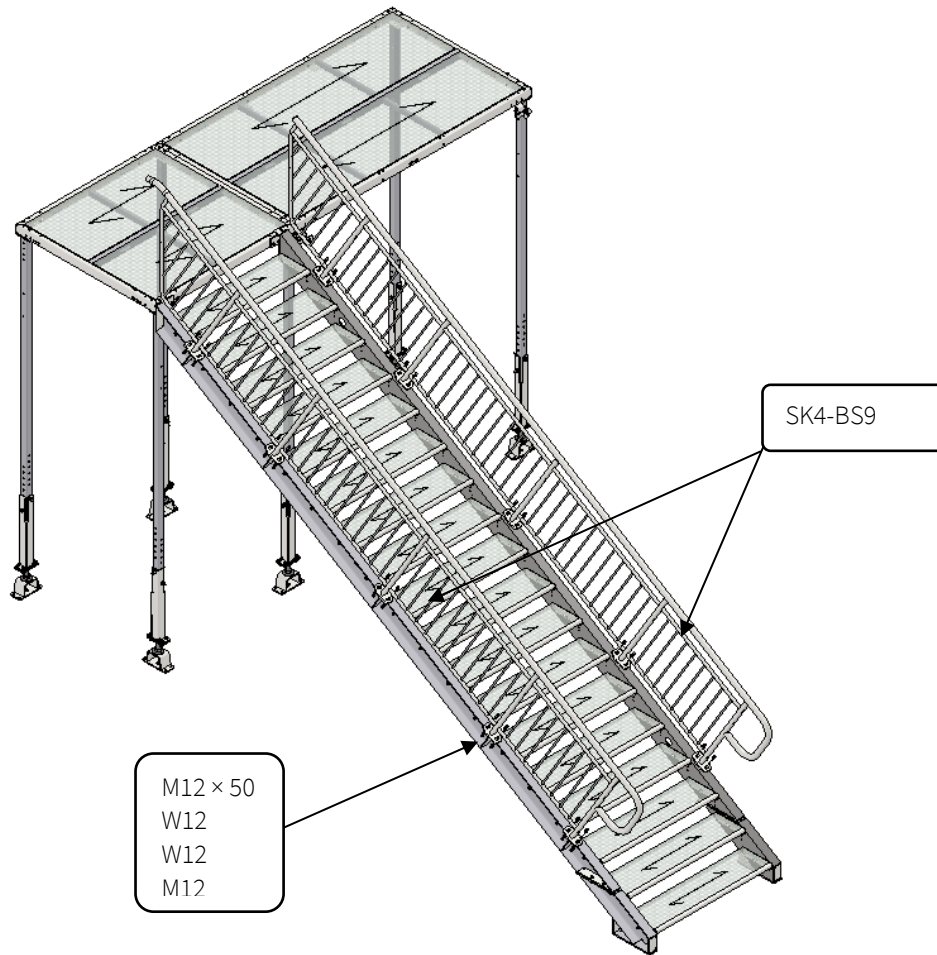

6.14. The barriers should be bolted to the platform using a bolt, washer, nut set. Connect barriers between each other using SK4-L14, SK4-L16.

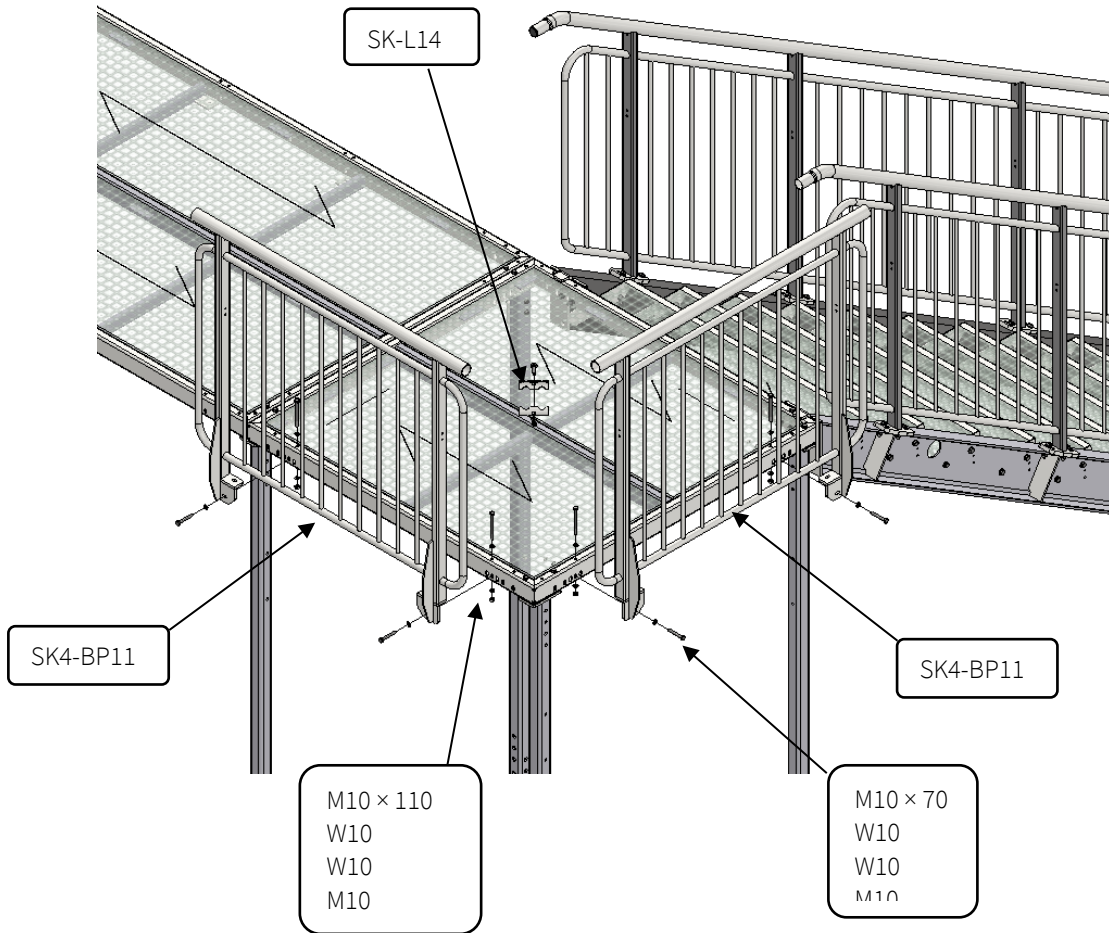

Connecting the handrail to the railing on the platform

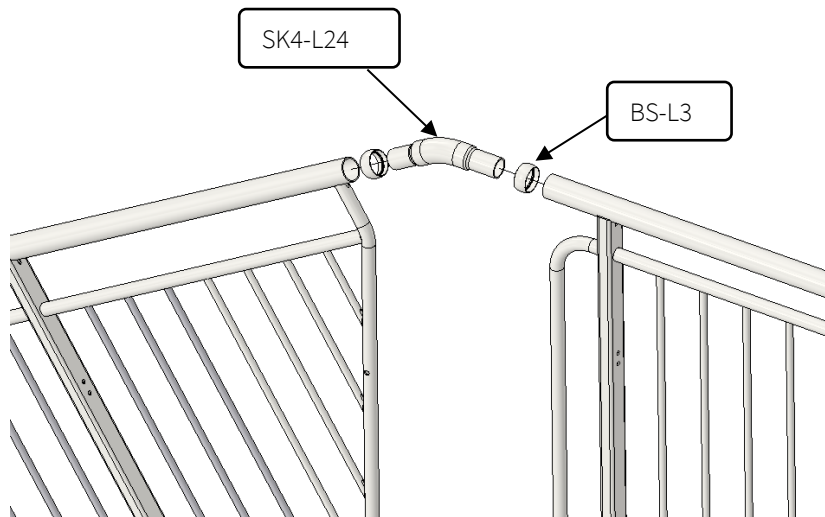

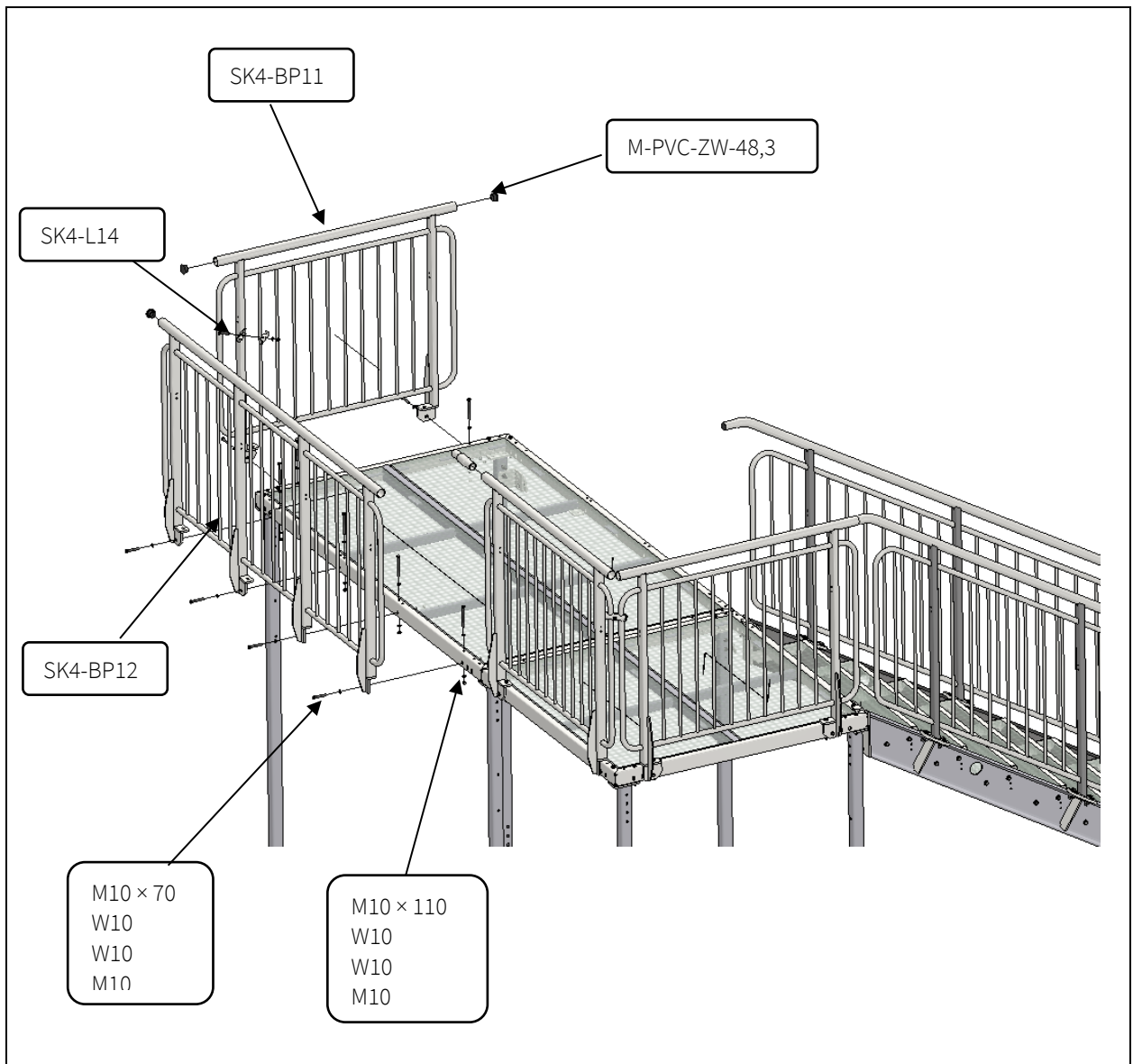

Connecting the handrail on the platform with that on the platform

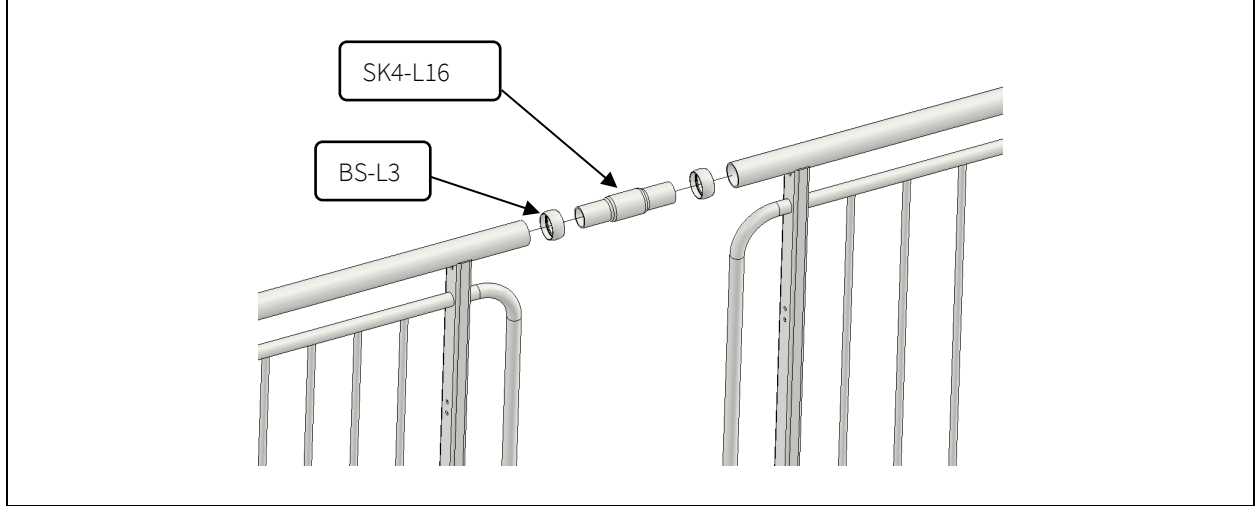

6.15. Install SK4-X3 bracing using bolt, washer, nut assemblies.

