

Attachment no. 1

Assembly manual of

TAS System Staircase

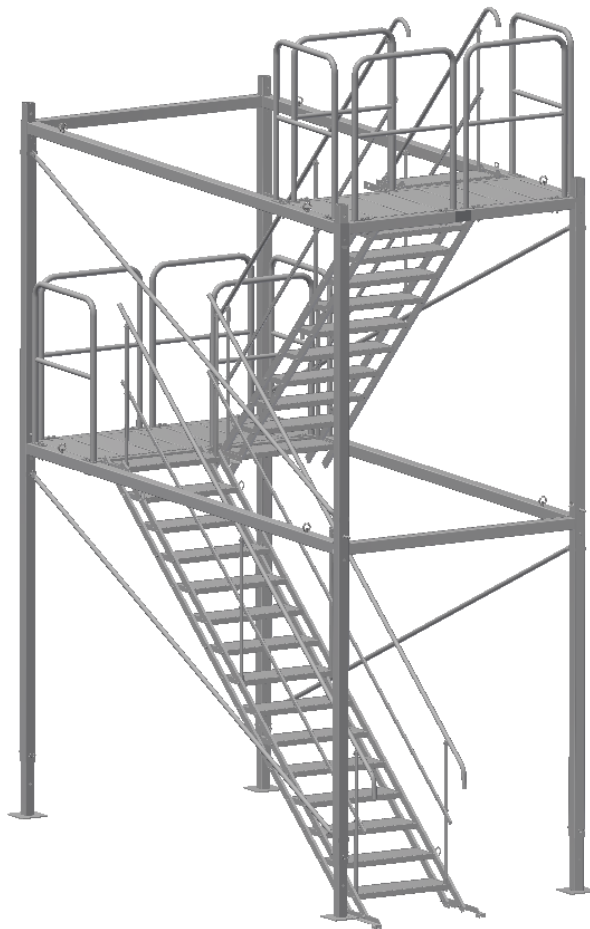

Robert Cieśla
(Prepared by)

Cieśla
.....
(Signature)

Piotr Abram
(Checked by)

Piotr Abram
.....
(Signature)

Mitosz Muzyka
(Approved by)

Mitosz Muzyka
.....
(Signature)

Release 3.5, May 2023

Table of content

1	Assembly manual	4
2	Components of the TAS system staircase	4
3	List of tools required for container stairs assembly.	9
4	Assembly of the staircase	10
4.1	Activities prior to assembly	10
4.2	Adjustment of the descent level	11
4.3	Assembly.....	13
4.3.1	Zone designation.....	13
4.3.2	Assembly of the railings to the platform	13
4.3.3	Foot assembly	15
4.3.4	Assembly of the post to the frame	16
4.3.5	Bracing assembly	17
4.3.6	Inspection	18
4.3.7	Stairs assembly	19
4.3.8	Assembly of the railings to the middle module	20
4.3.9	Assembly of the posts to the frame.....	21
4.3.10	Bracing assembly	23
4.3.11	Assembly of the stairs to the middle module	24
4.3.12	Assembly of the middle module on the lower module.....	25
4.3.13	Assembly of the middle module stairs to the lower module	26
4.3.14	Disassembly of the railings	27
4.3.15	Assembly of the staircase anchorage	27
4.4	Assembly of the descent.....	29
4.4.1	Assembly when the exit level is above the staircase platform	29
4.4.2	Removal of the bottom foot from the TAS-3A / 6A stairs.....	29
4.4.3	Assembly of the EPS-KS-A5 adapter to the TAS-3A / 6A stairs.....	30
4.4.4	Disassembly of the railing.....	30
4.4.5	Assembly of the upward descent	31
4.4.6	Assembly when the exit level is below the level of the staircase platform.....	32
4.4.7	Disassembly of the upper foot from the TAS-3A / 6A stairs.....	32
4.4.8	Disassembly of the step from the EPS-KS-A5 adapter	33
4.4.9	Assembly of the EPS-KS-A5 adapter to the TAS-3A / 6A stairs.....	33
4.4.10	Disassembly of the railing.....	34
4.4.11	Assembly of the downward descent.....	34

Table of changes

No	FULL NAME	DEPT.	DATE OF CHANGE	SCOPE OF CHANGE	NOTES
1	Robert Cieśla	R&D	6.03.2019	Full document update	p. 2, 3, 4
2	Miłosz Muzyka	R&D	15.05.2020	Information on the possible use of TAS-6A has been added	
3	Robert Cieśla	R&D	12.05.2023	Height of staircase update	tab. 6, 7 drw. 1, 2
4					
5					
6					
7					
8					
9					
10					
11					
12					
13					
14					
15					

1 Assembly manual

The assembly instructions is an attachment to the operation and maintenance document of the TLC staircase.

The staircase consists of elements fitting the specification added to the delivery.

There are bolt and pin connections in the staircase. The staircase is delivered in the form of separate elements, such as platforms, railings, steps, connectors, stairs, posts. Elements are assembled in a specific sequence.

The staircase consists of modules that can be stacked, depending on the needs, up to 4 layers; providing appropriate stabilization conditions, i.e. the appropriate ground and fixing with anchors to permanent structures, e.g. walls, columns.

2 Components of the TAS system staircase

The list of elements in Table 1 presents the components of a single staircase module and their assembly quantities.

Table 1 List of components

No.	ID	Description	quantity in the lower module	quantity in the middle module
1	EPS-KS-S1	Post	4	4
2	EPS-KS-A1	Foot	4	0
3	EPS-KS-RA	Frame	1	1
4	EPS-KS-X1	Bracing	2	2
5	EPS-KS-O	Clamp 80x80	4	4
6	EPS-KS-R1	Railing	5	5
7	EPS-KS-A2	Connector	0	2
8	EPS-KS-A3	Connector	0	2

Table 2 List of fasteners

No.	ID	Description	Quantity
A	ISO 7089 -12	ISO 7089-12-200 HV washer	48
B	ISO 4032 - M12	ISO 4032 - M12 nut	24
C	ISO 4017 - M12 x 110	ISO 4017 - M12 x 110 bolt	16
D	ISO 7089 -8	ISO 7089 -8 - 200 HV washer	8
E	DIN 582 - M16 - 2	DIN 582 - M16 - 2 ring nut	4
F	ISO 7089 -16	ISO 7089 -16 - 200 HV washer	4
G	ISO 4017 - M16 x 110	ISO 4017 - M16 x 110 bolt	4
H	ISO 4017 - M12 x 90	ISO 4017 - M12 x 90 bolt	4
I	ISO 4014 - M8 x 40	ISO 4014 - M8 x 40 bolt	4
J	ISO 4032 - M8	ISO 4032 - M8 nut	4
K	ISO 4014 - M12	ISO 4014 - M12 x 100 bolt	4
L	M-Z-SW-ZACZ-19	19 mm safety hitch pin	4

Table 3 List of stairs

No.	ID	Description	Height
S1	EPS-SHD-12	12 step stairs	2145-2330
S2	EPS-SHD-15	15 step stairs	2330-2515
S3	EPS-SHD-18	18 step stairs	2515-2883

Table 4 Components of a staircase

EPS-KS-RA

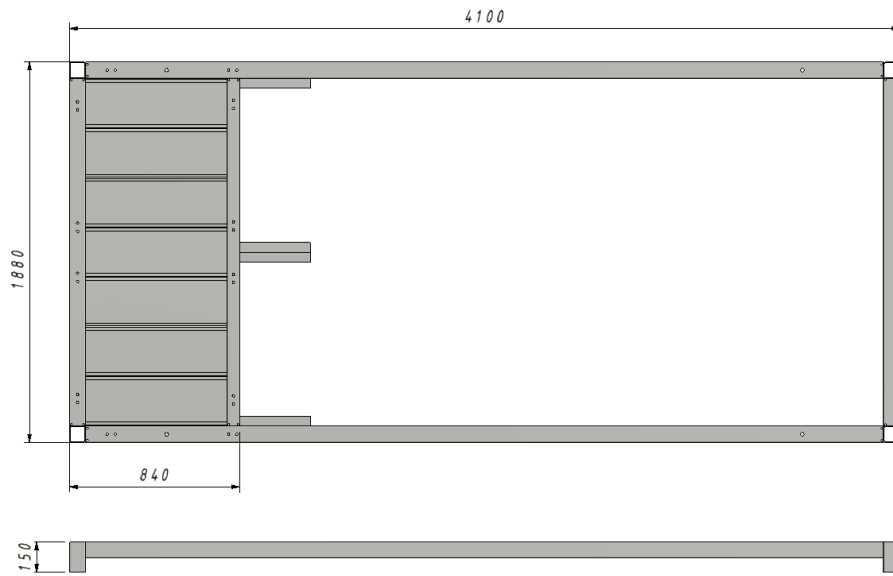

Weight 122.61 kg

EPS-KS-S1

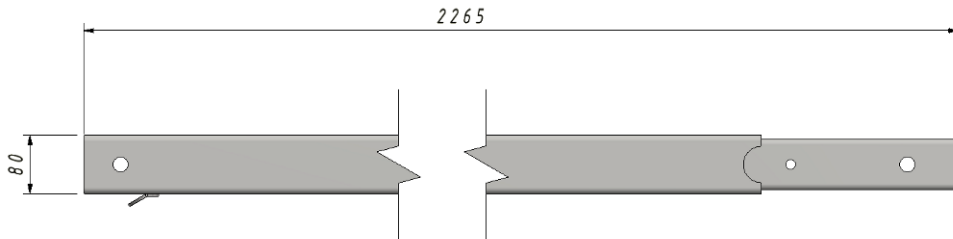

Weight: 20.78 kg

EPS-KS-A1

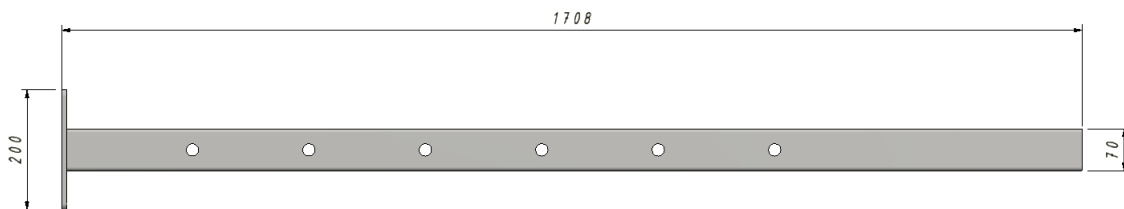

Weight: 12.08 kg

EPS-KS-X1

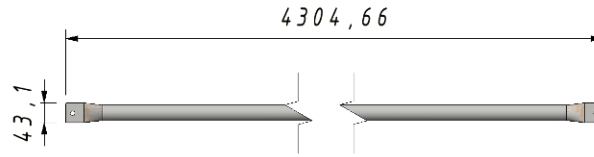

Weight 7.63 kg

EPS-KS-O

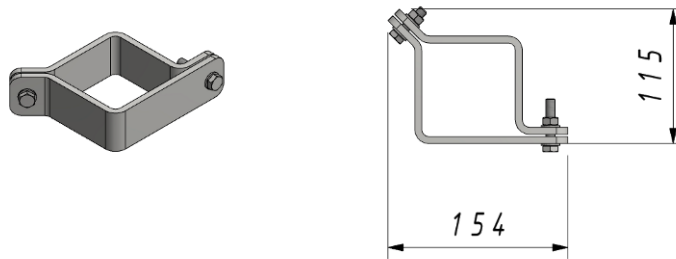

Weight 0.9 kg

EPS-KS-R1

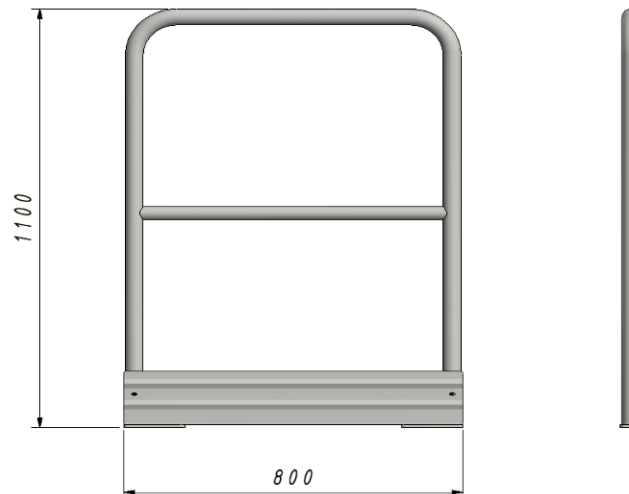

Weight 13.610 kg

EPS-KS-A2

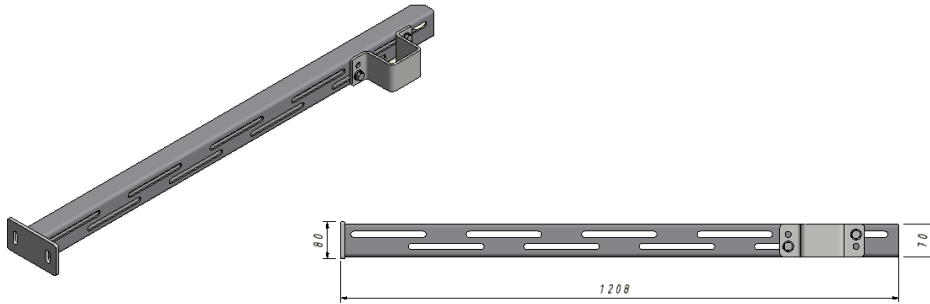

Weight: 7.1 kg

EPS-KS-A3

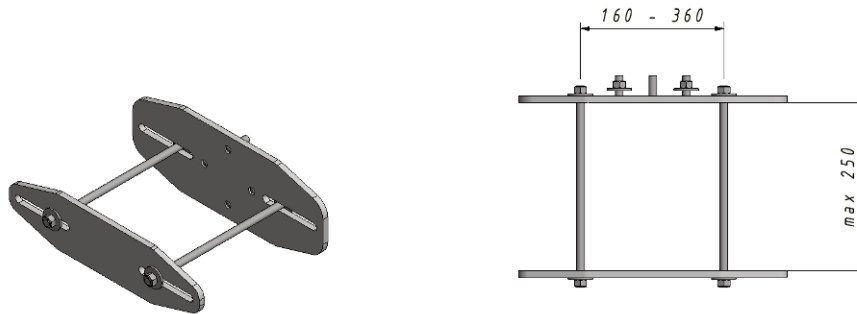

Weight: 6.777 kg



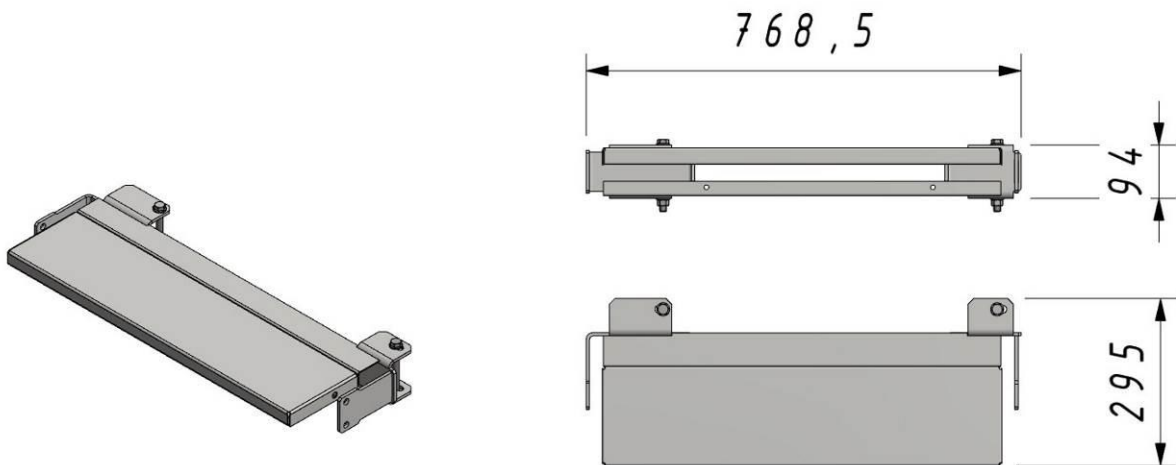

EPS-KS-A5



Weight: 8.3 kg

3 List of tools required for container stairs assembly.

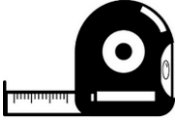
Table 5 List of tools

	Wrenches: 24, 18, 13
	Level
	Tape measure
	Lifter with at least 1 t capacity
	Height depends on the number of modules max. 10m

4 Assembly of the staircase

4.1 Activities prior to assembly

Before starting the assembly, check the quantity and condition of all elements. Plan the entrance and exit from the staircase, prepare the ground.

The available staircase heights are shown in Fig. 1. In Table 6. the height of the modules which is adjusted on the posts of the lower module is shown. In table 7. height range when adjusting it on the posts of the lower module and adjusting when leaving the staircase is shown (with use of additional TAS-3A or TAS-6A stairs).

		0	1	2	3	4	5	6
MD		2150	2305	2500	2695	2890	3085	3280
MD	MS x 1	4295	4450	4645	4840	5035	5230	5425
MD	MS x 2	6440	6595	6790	6985	7180	7375	7570
MD	MS x 3	8585	8740	8935	9130	9325	9520	9715

Table 6 Height of the module from the ground in mm, step-adjustable from 0 to 6: MD - lower module; MS - middle module,

				TAS-3A		TAS-6A	
		min	max	min	max	min	max
MD		2150	3280	1580	3718	1009	4292
MD	MS x 1	4295	5425	3725	5863	3162	6437
MD	MS x 2	6440	7570	5872	8010	5307	8582
MD	MS x 3	8585	9715	8017	10155	7452	10727

Table 7 The height of the descent from the ground in mm: MD - lower module; MS - middle module

4.2 Adjustment of the descent level

Additionally, by using the adapter and TAS-3A or TAS-6A stairs, it is possible to additionally adjust the height of the descent from the staircase platform to the construction level. Adjustment is possible both upwards and downwards.

The possible descent heights with the use of additional TAS-3A or TAS-6A stairs are shown in the figures below.

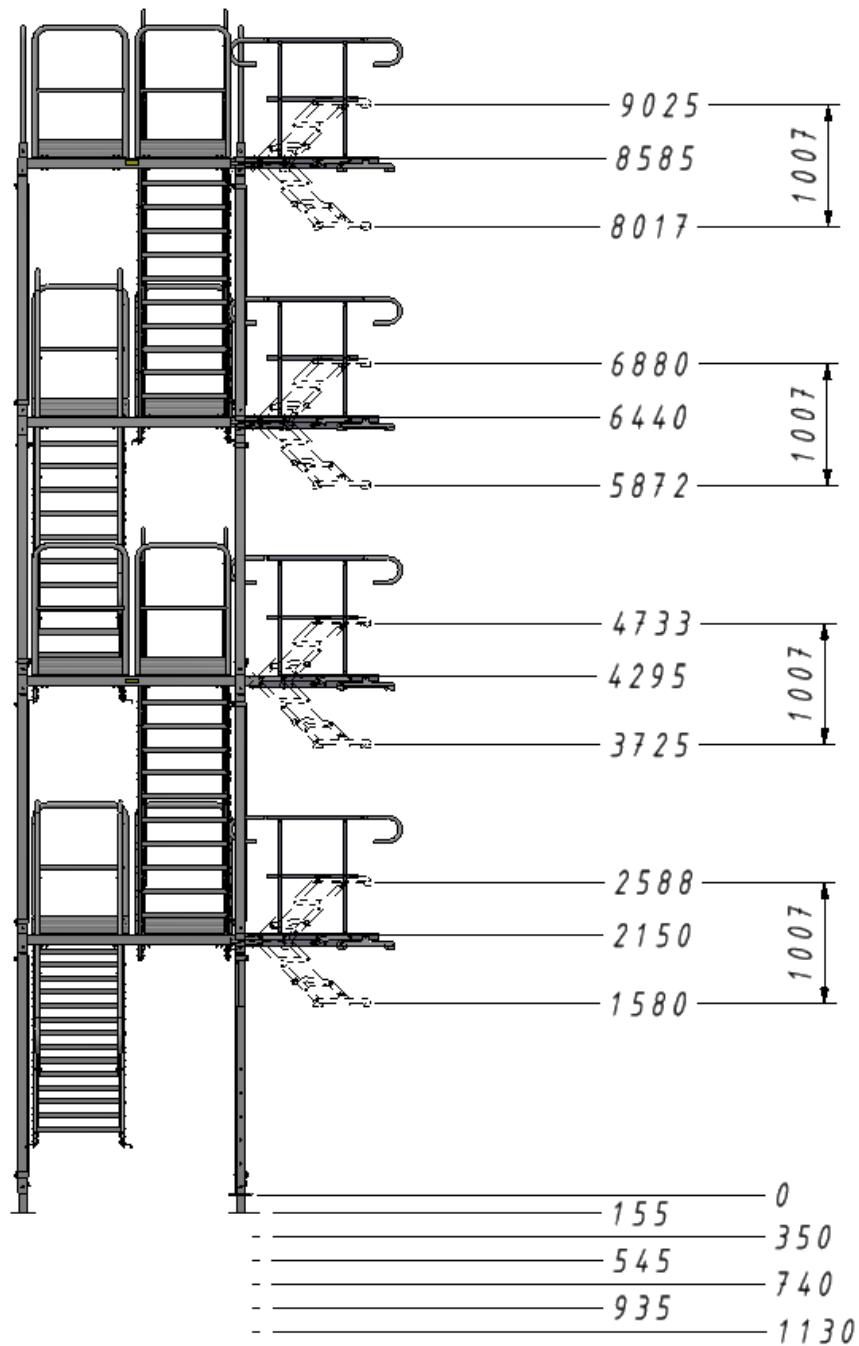

Fig. 1 Available heights when using the additional TAS-3A stairs

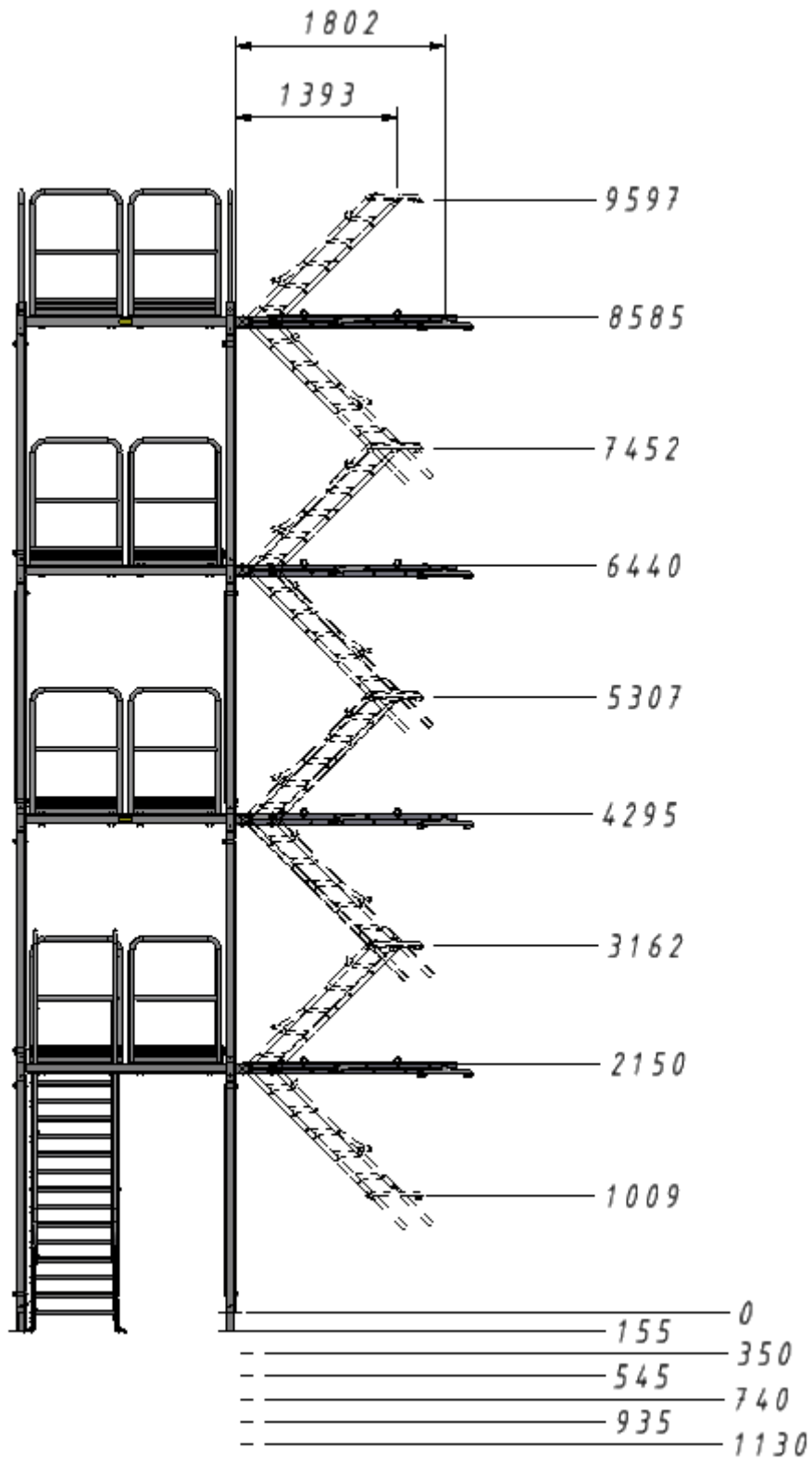

Fig. 2 Available heights when using the additional TAS-6A stairs

4.3 Assembly

4.3.1 Zone designation

Designation of a safe assembly zone at least 6 m from the work carried out

- 1. Staircase assembly site
- 2. Pre-assembly component site
- 3. Work zone

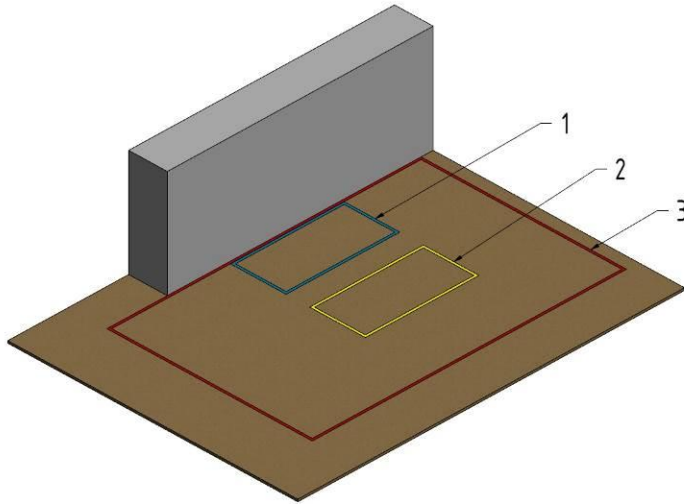

4.3.2 Assembly of the railings to the platform

The railings should be assembled to the frame using a set of a bolt + 2 washers + a nut, repeat the activity for each railing. Omit the railing in the place of fixing the stairs leading to the platform.

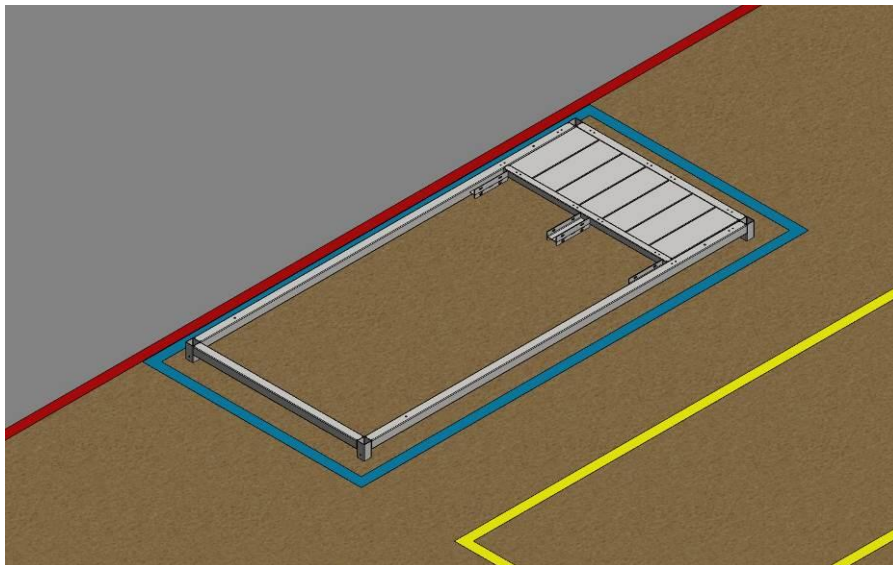

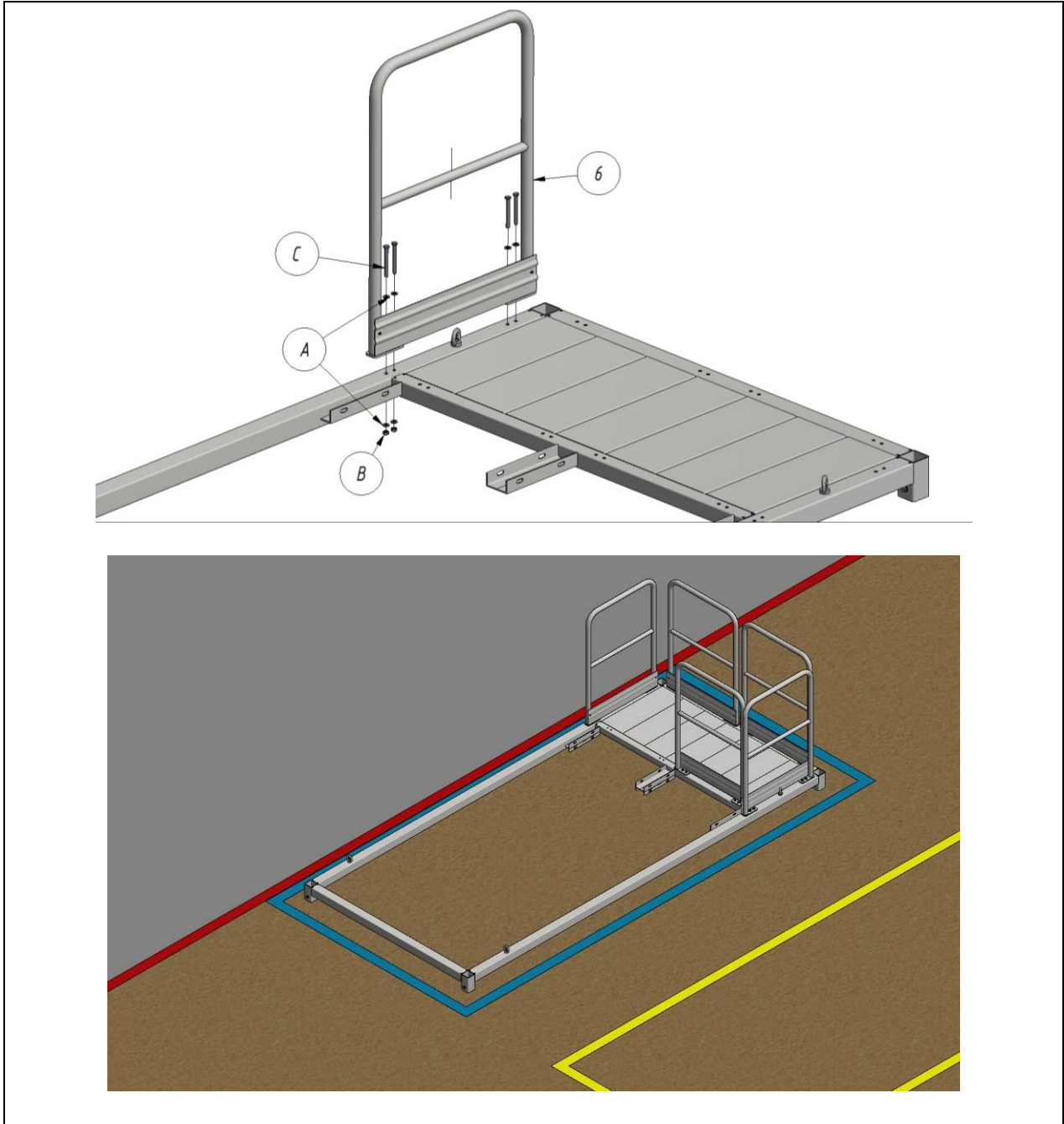

4.3.3 Foot assembly

Set the height for each post as needed.

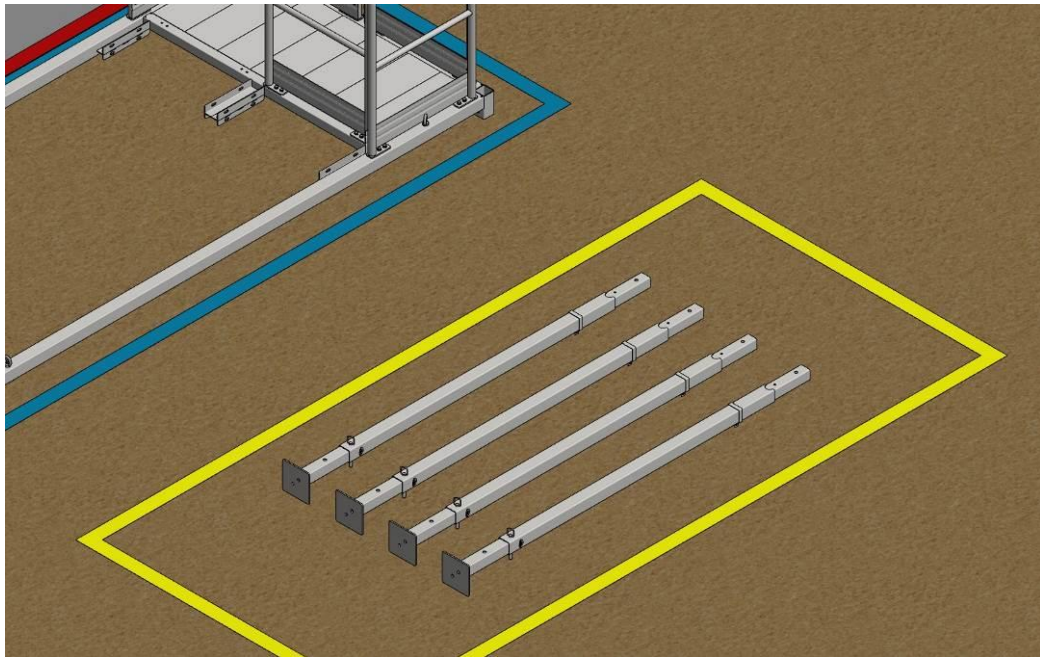
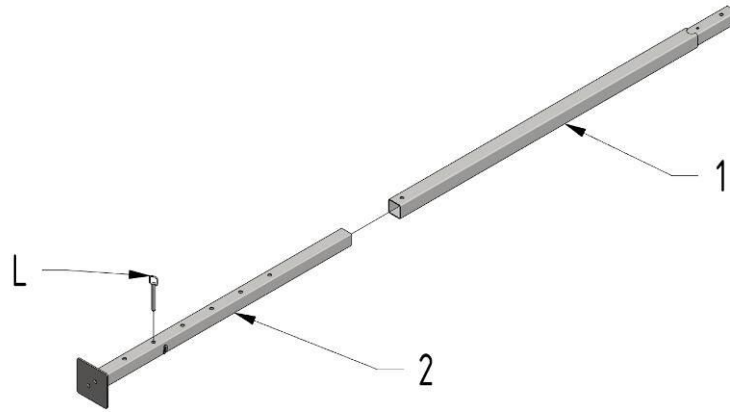

4.3.4 Assembly of the post to the frame

Lift the frame up gripping the ring nuts with the use of a lifter, then place the posts in the holes located in the frame and secure it with a set of a bolt + 2 washers + a nut.

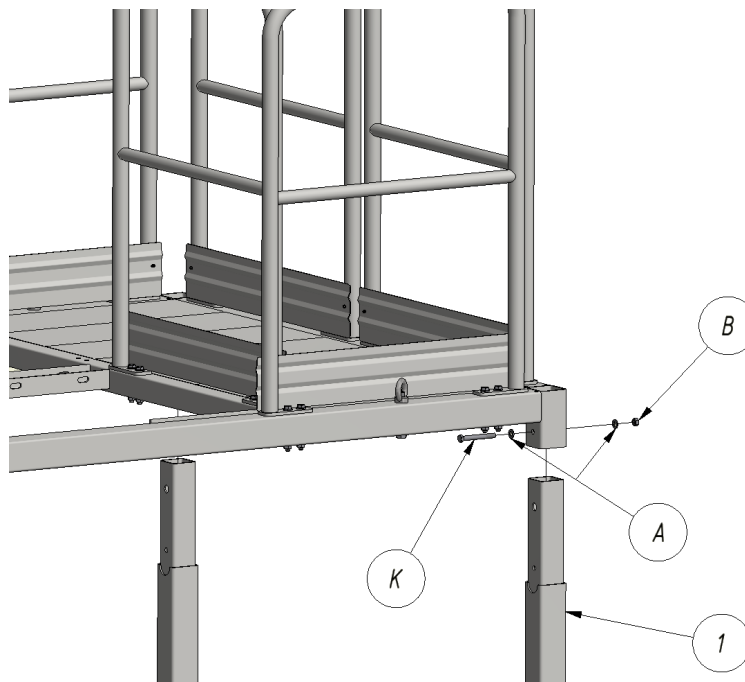
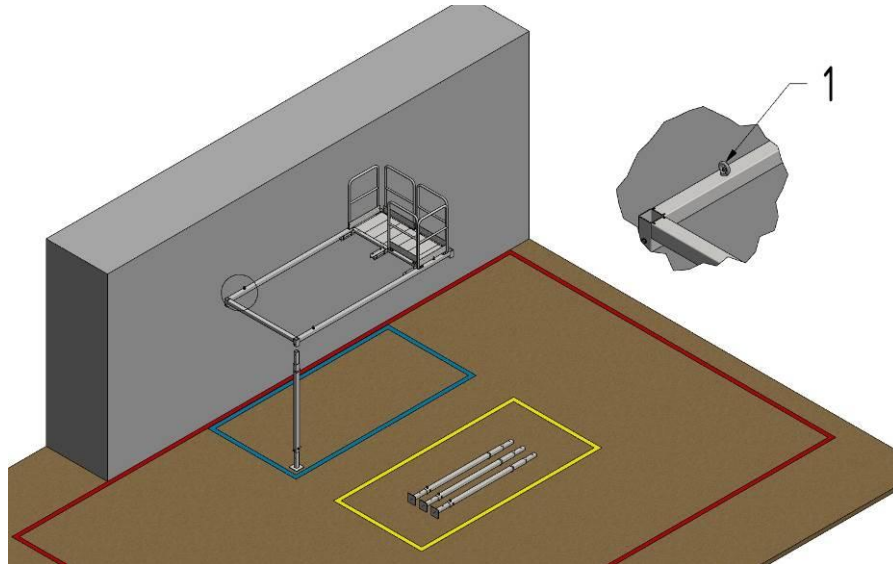

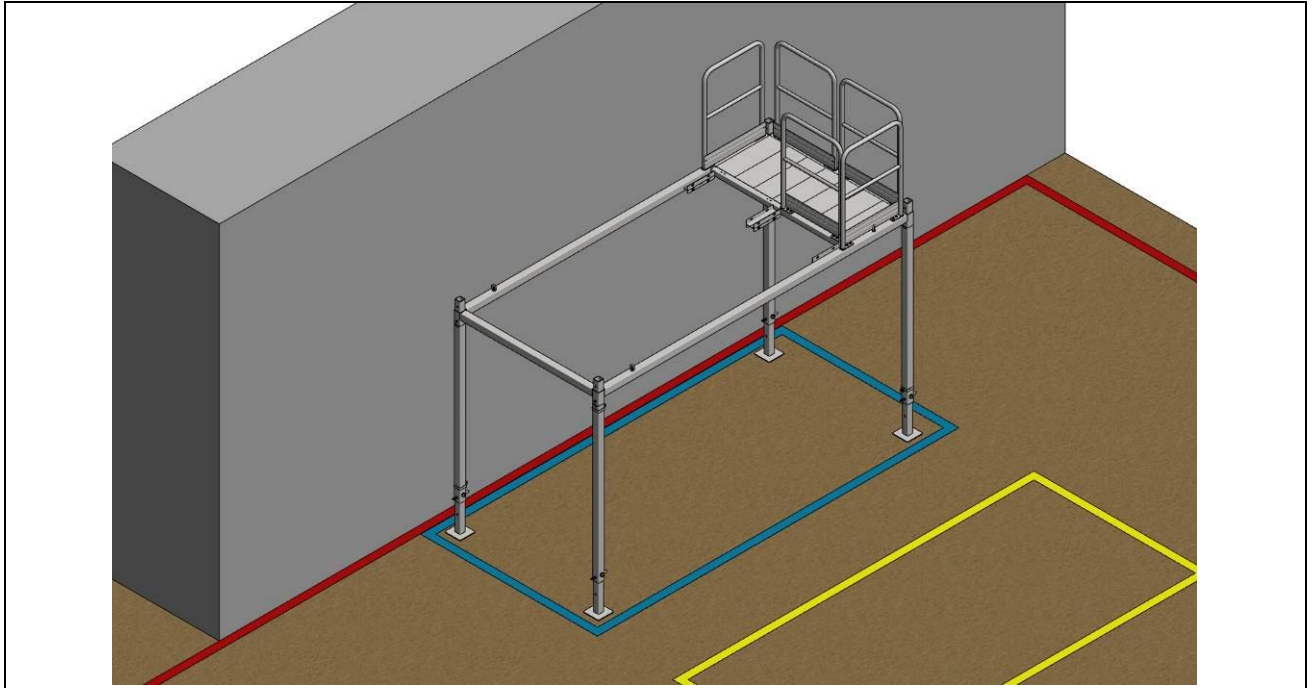

4.3.5 Bracing assembly

Assemble the bracings diagonally between the posts with a clamp.

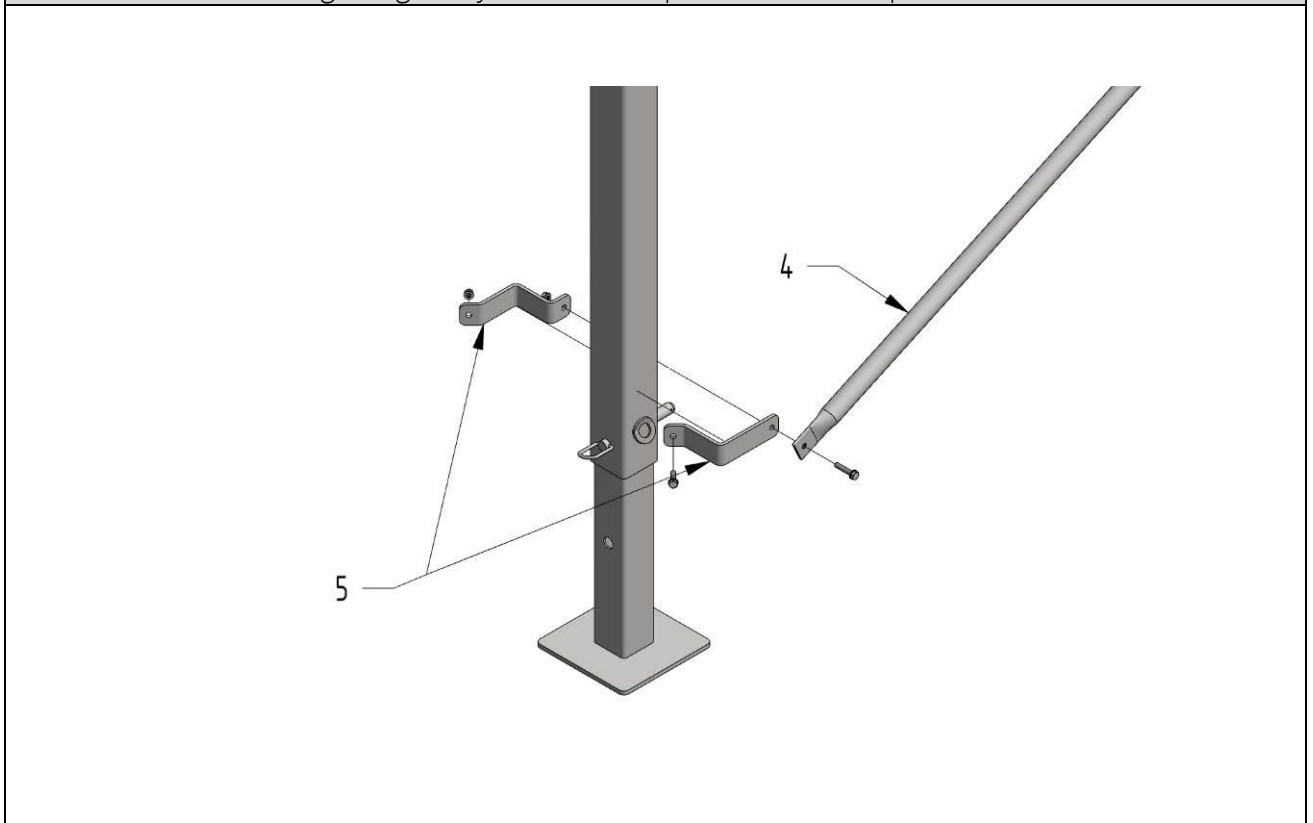

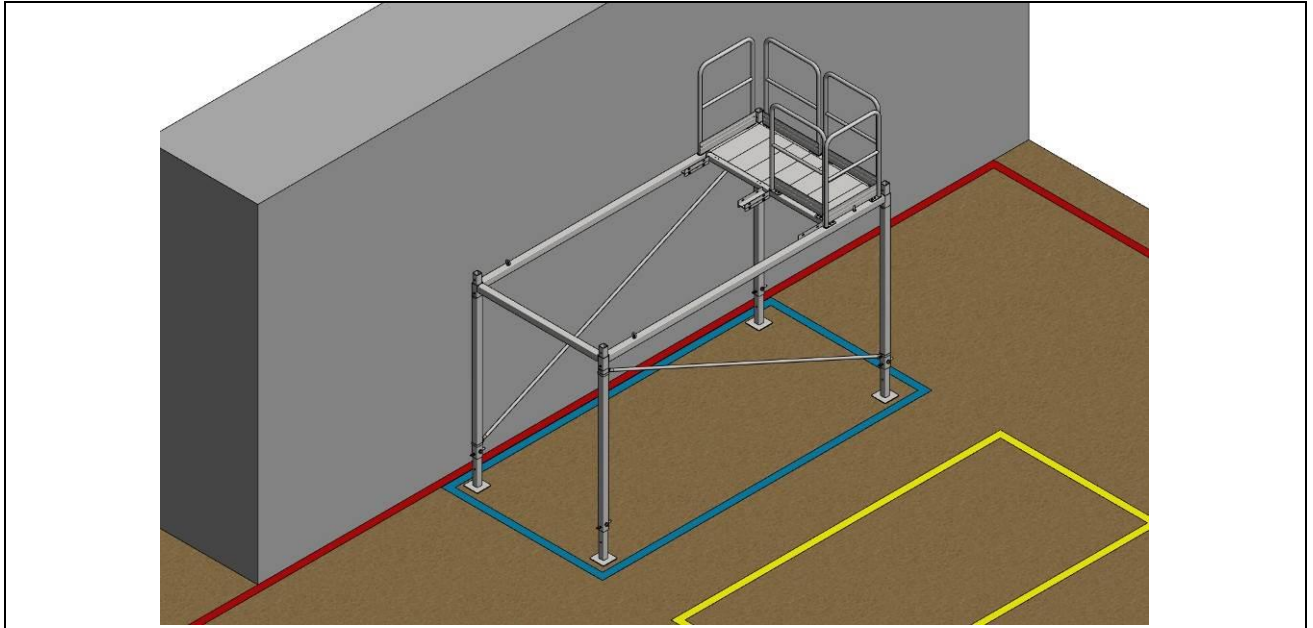

4.3.6 Inspection

- Check and, if necessary, level the lower staircase module - check screw connections

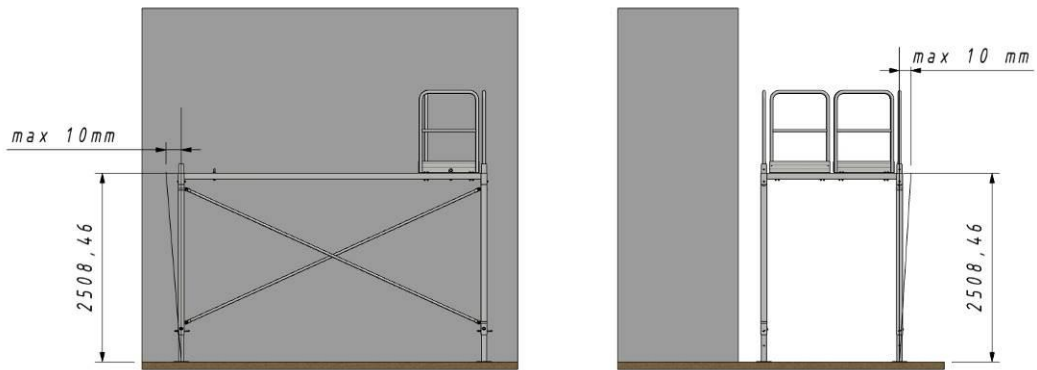

4.3.7 Stairs assembly

The choice of stairs in the lower module depends on the height set on the posts. The stairs are screwed to the module with a set of a bolt + 2 washers + a nut, used for assembly of the last step of the stairs.

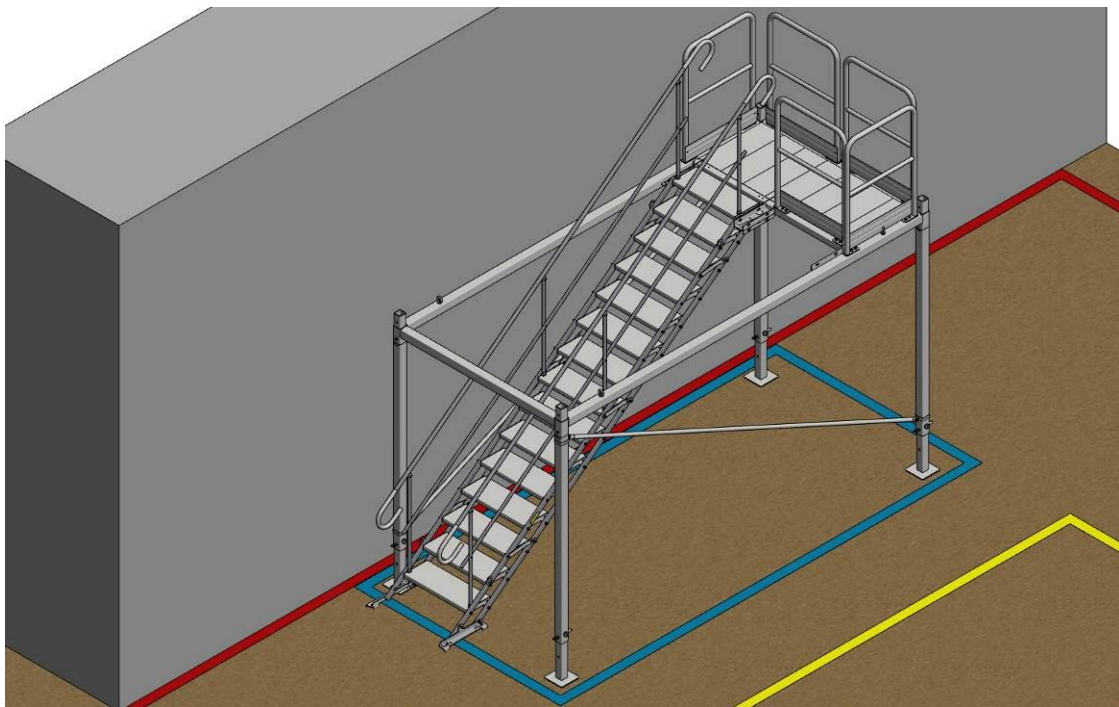
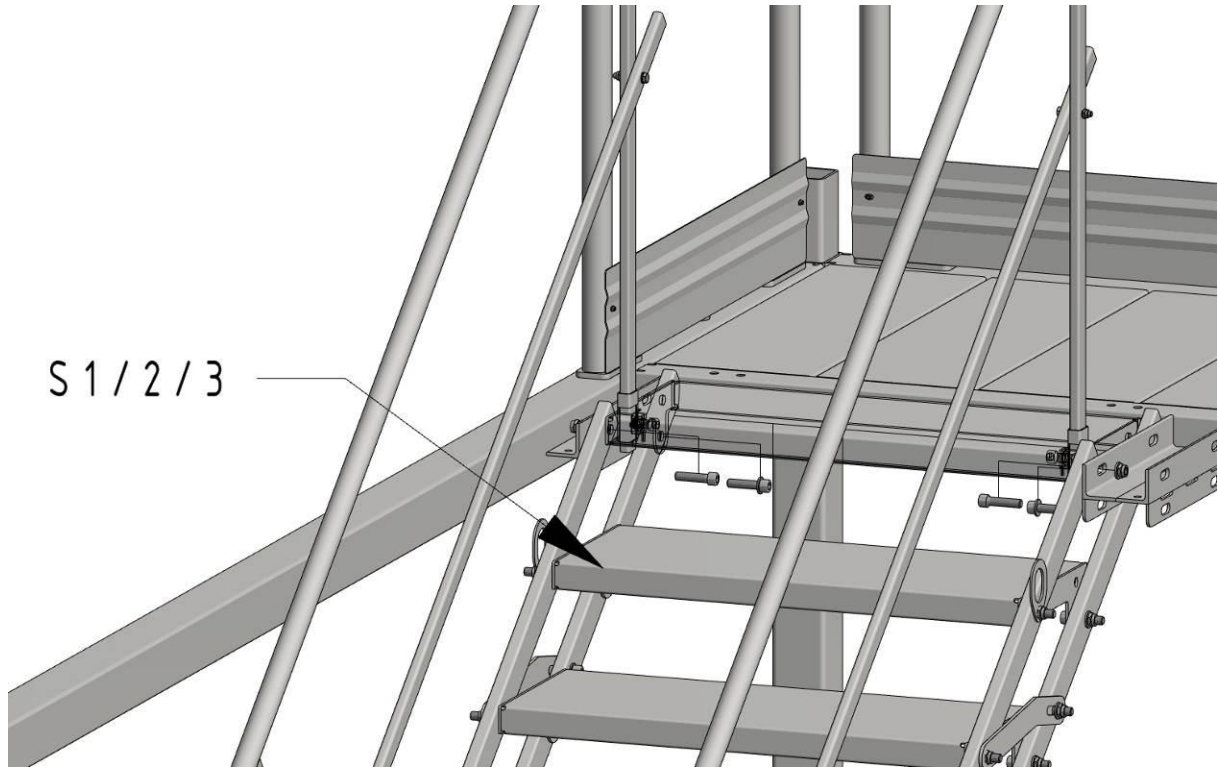

The end of the lower module assembly.

4.3.8 Assembly of the railings to the middle module

The railing should be assembled to the frame using a set of a bolt + 2 washers + a nut, repeat the activity for each railing. Omit the railing in the place of fixing the stairs leading to the platform.

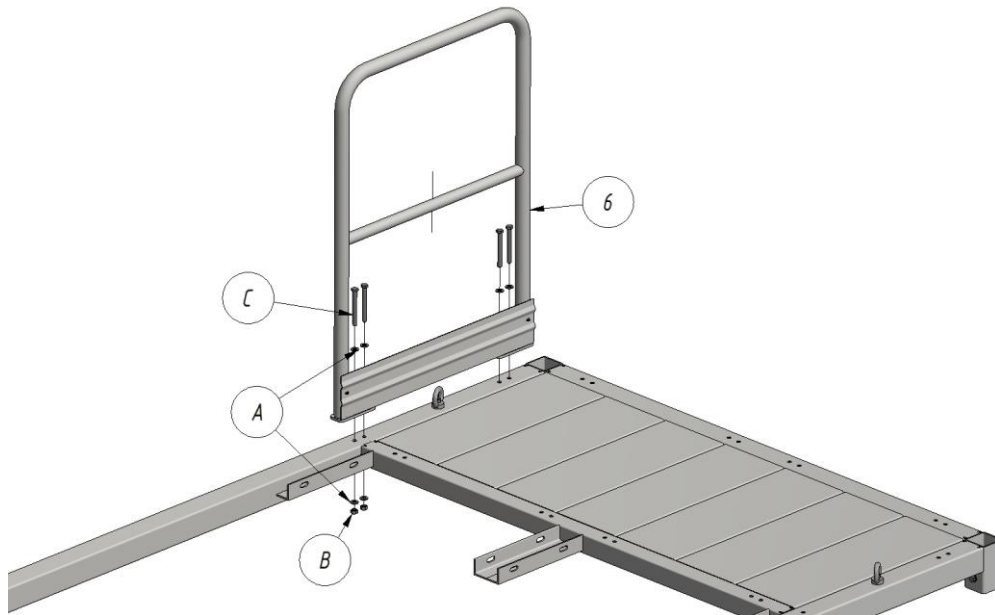
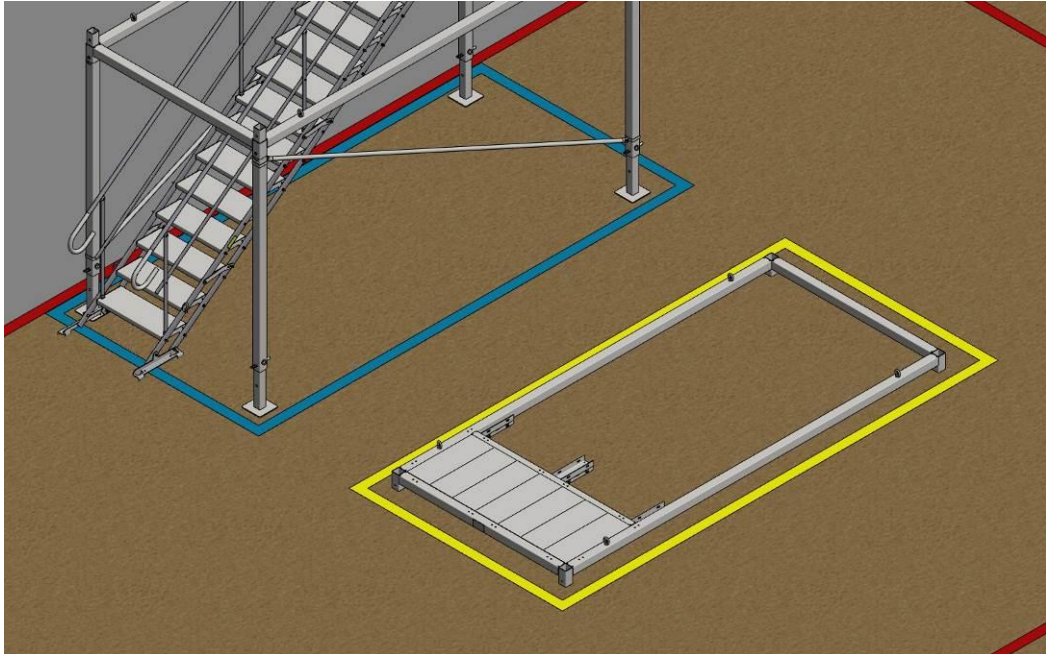

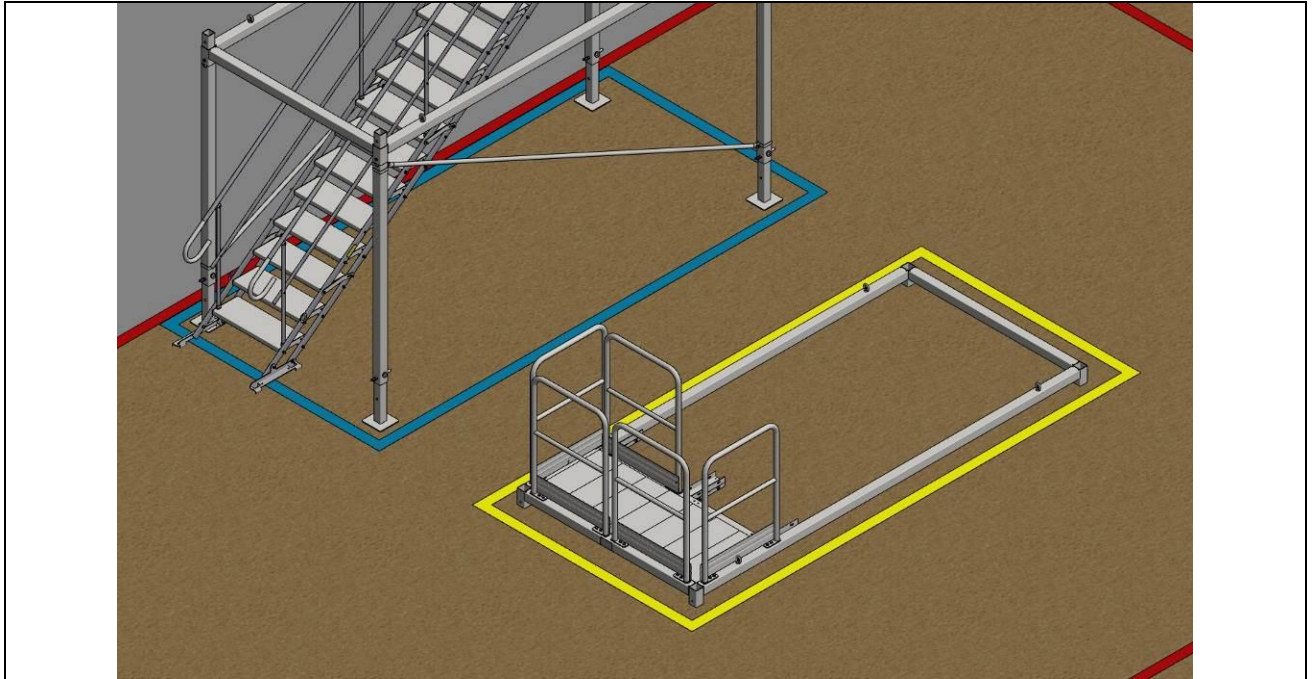

4.3.9 Assembly of the posts to the frame

Lift the frame up gripping the ring nuts with the use a lifter, then place the posts in the holes located in the frame and secure it with a set of a bolt + 2 washers + a nut.

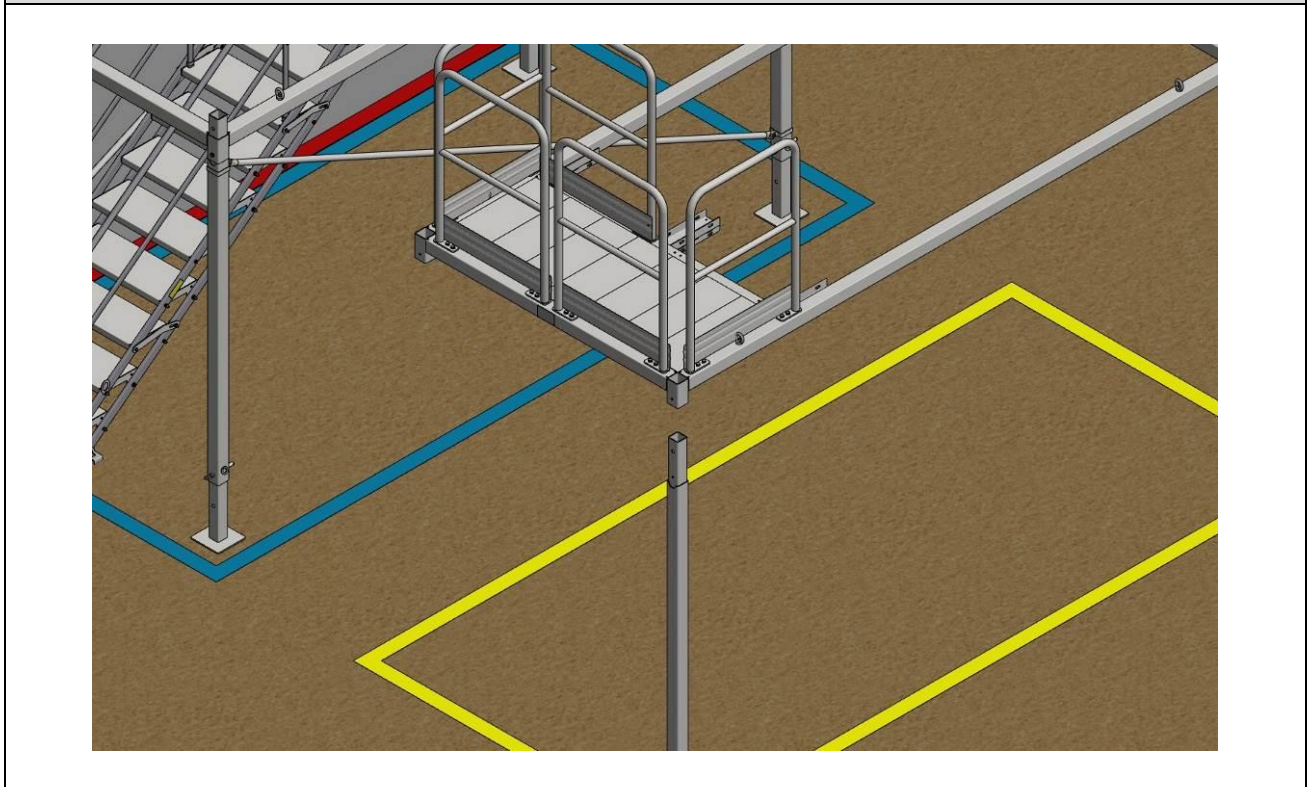

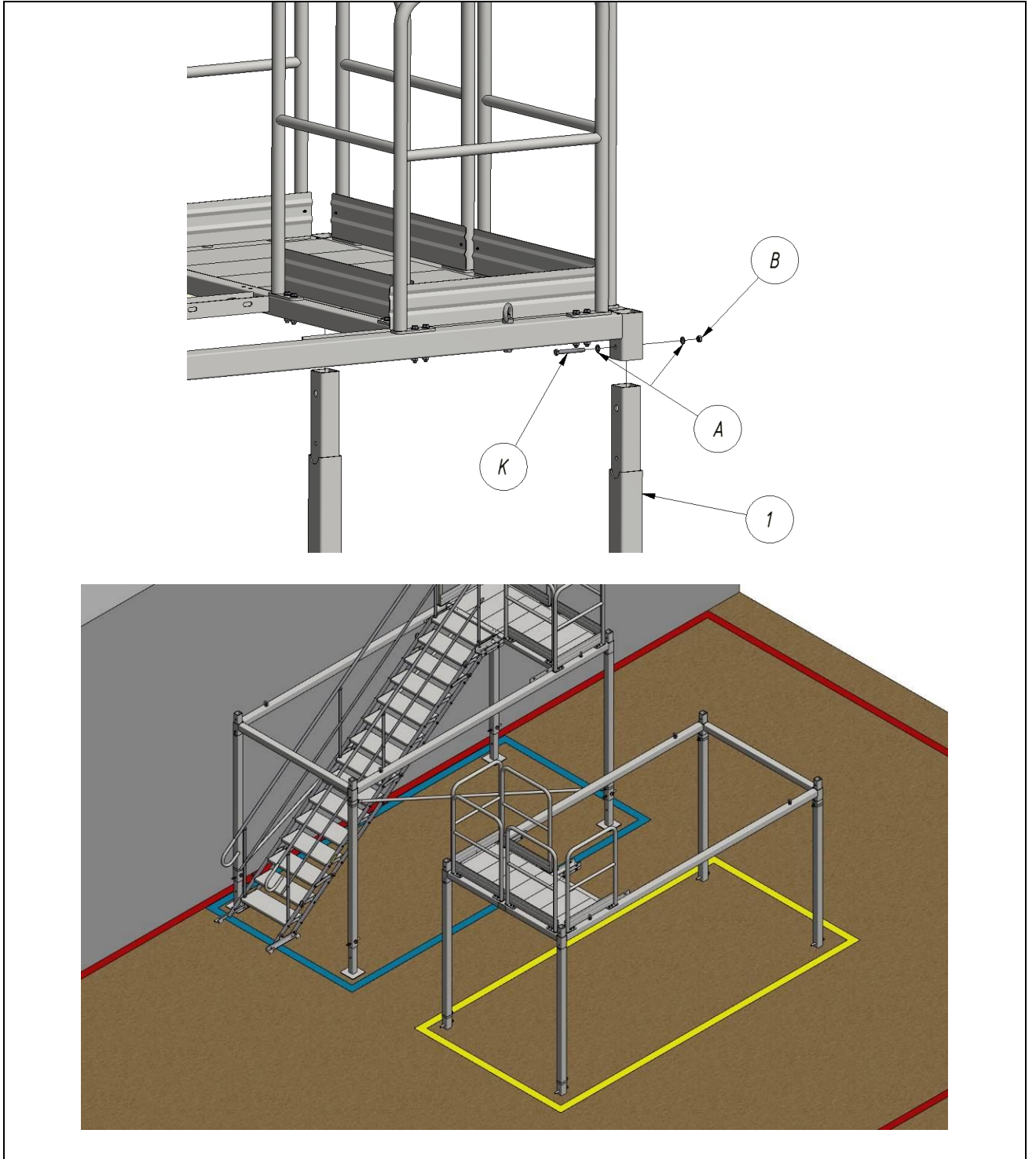

4.3.10 Bracing assembly

Assemble the bracings diagonally between the posts with a clamp.

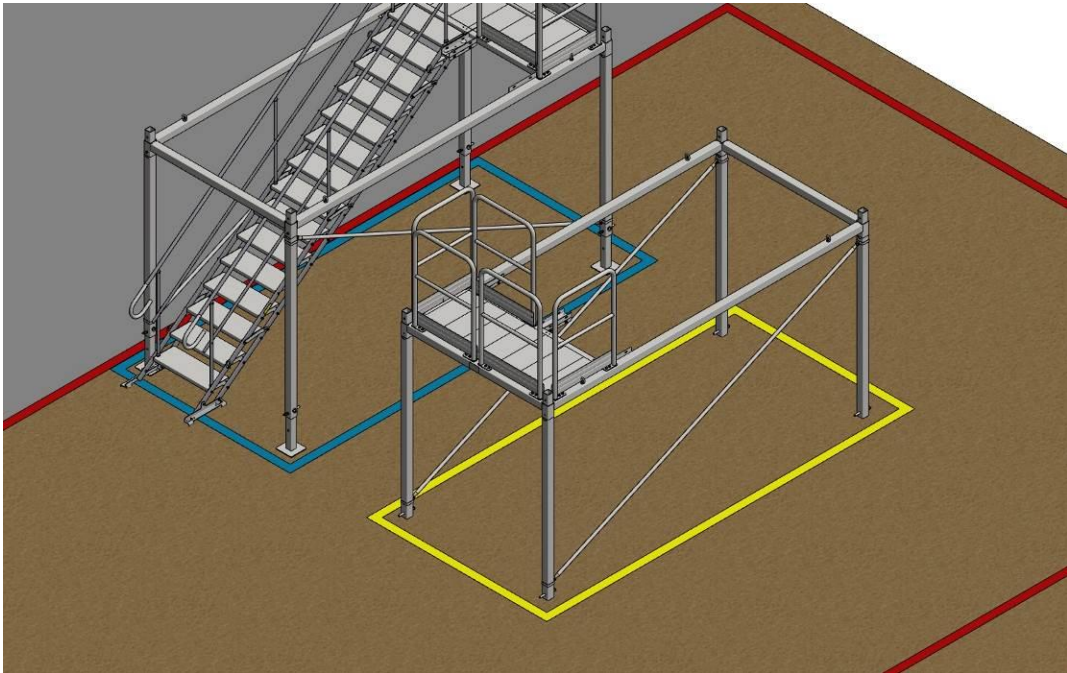
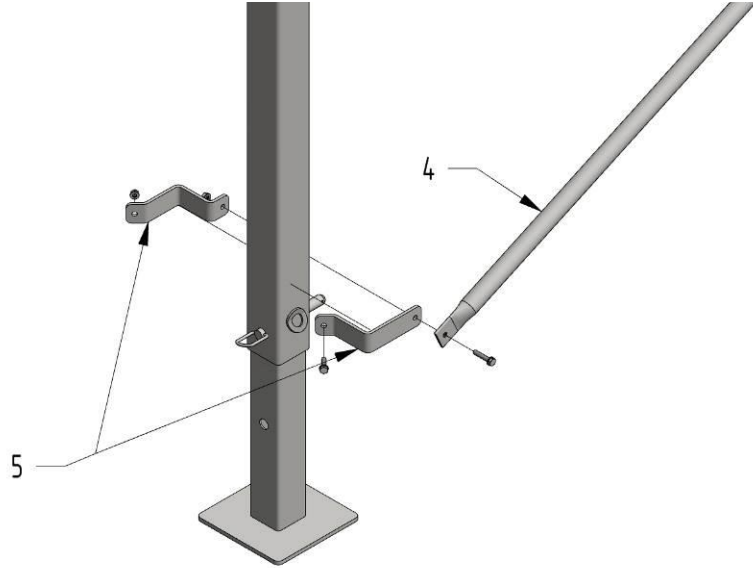

4.3.11 Assembly of the stairs to the middle module

Assemble the stairs to the middle module using the set of a bolt + 2 washers + a nut, used to mount the last step of the stairs.

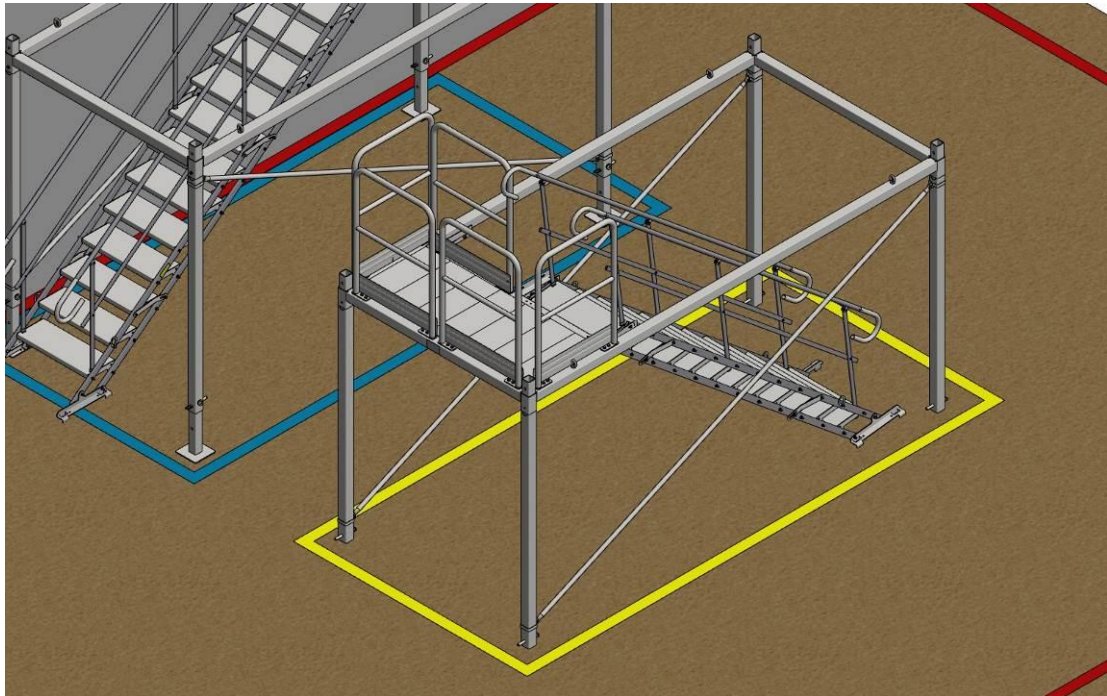
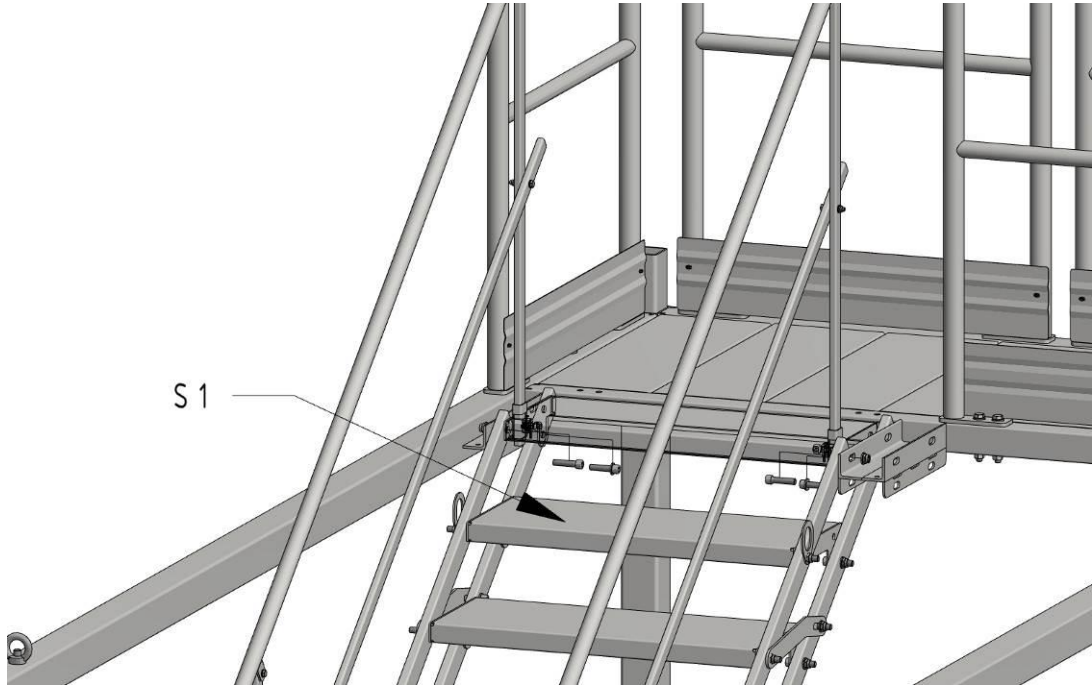

4.3.12 Assembly of the middle module on the lower module

Using a lifter, we put one segment on the other one, securing it with pins.

WARNING! Use a basket lifter to secure it with pins

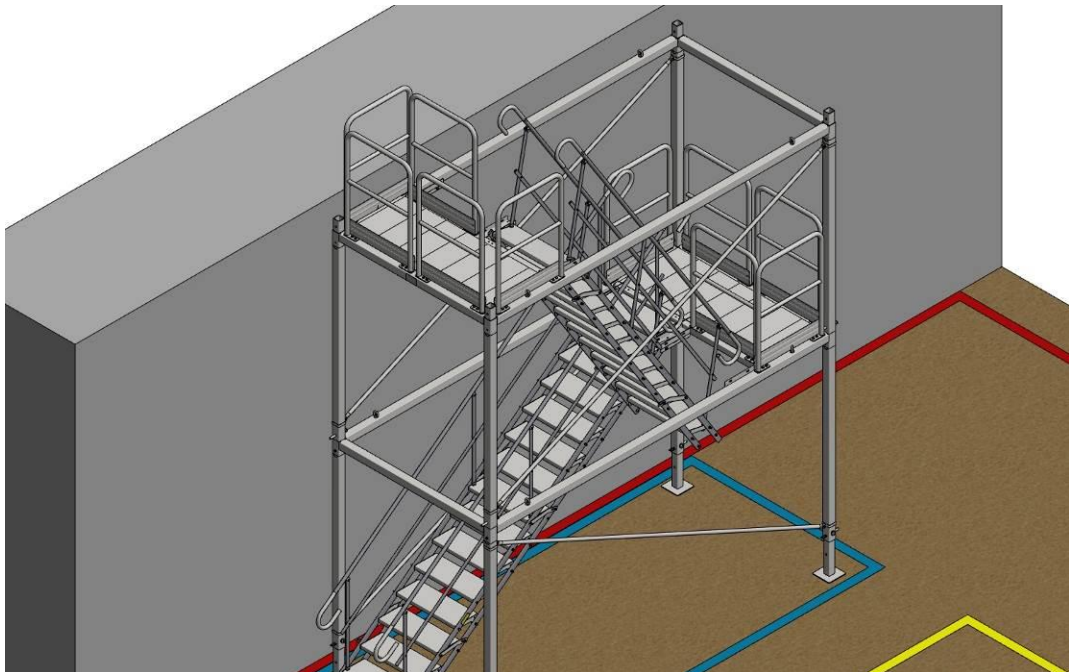

4.3.13 Assembly of the middle module stairs to the lower module

The stairs should be pulled to the frame and screwed together with the lower module using the set of a bolt + 2 washers + a nut, used for the assembly of the first step of the staircase.

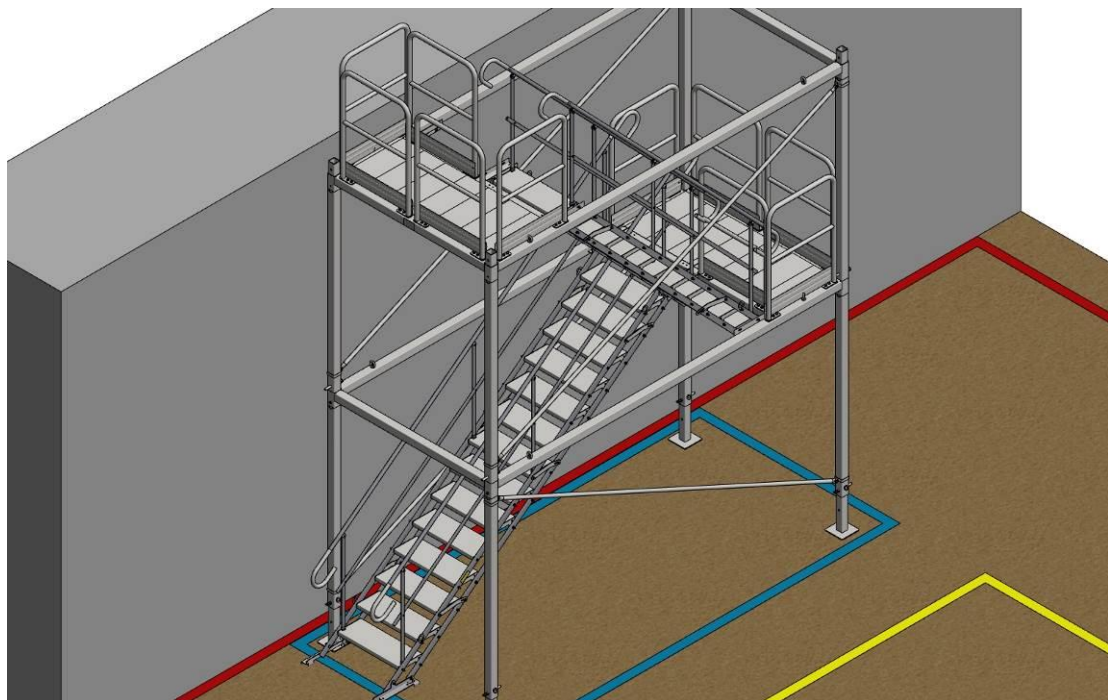
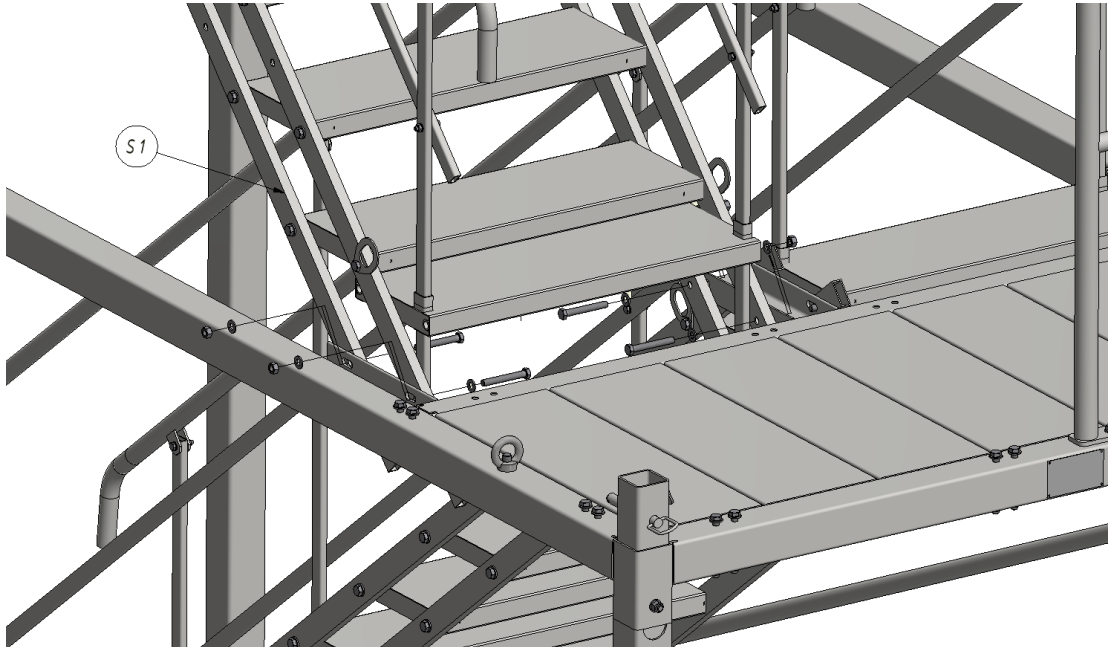

4.3.14 Disassembly of the railings

After assembly of the stairs to the lower module, remove the railing that previously secured the open space from the side of the assembled stairs.
Repeat the activity for other modules.

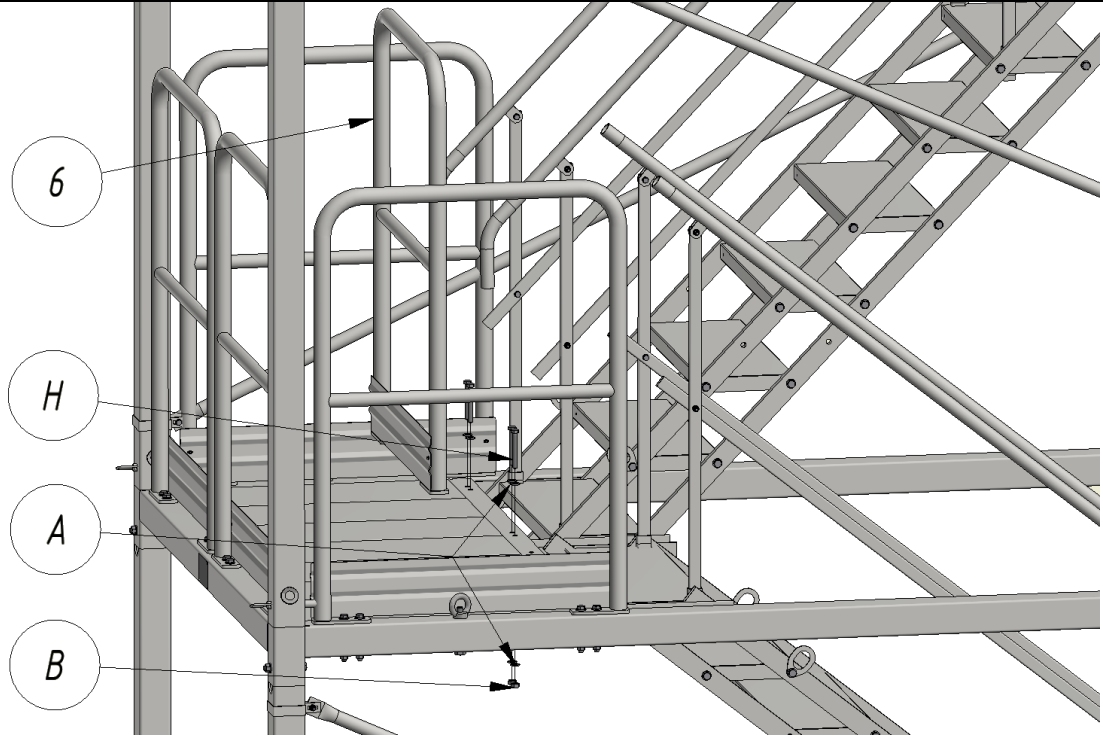

The end of the middle module assembly.

4.3.15 Assembly of the staircase anchorage

WARNING! Each middle module of the staircase should be anchored to the structure

An example of assembly to the post.



An example of assembly to the wall. The set does not include mounting pins / anchors for fixing in the wall.

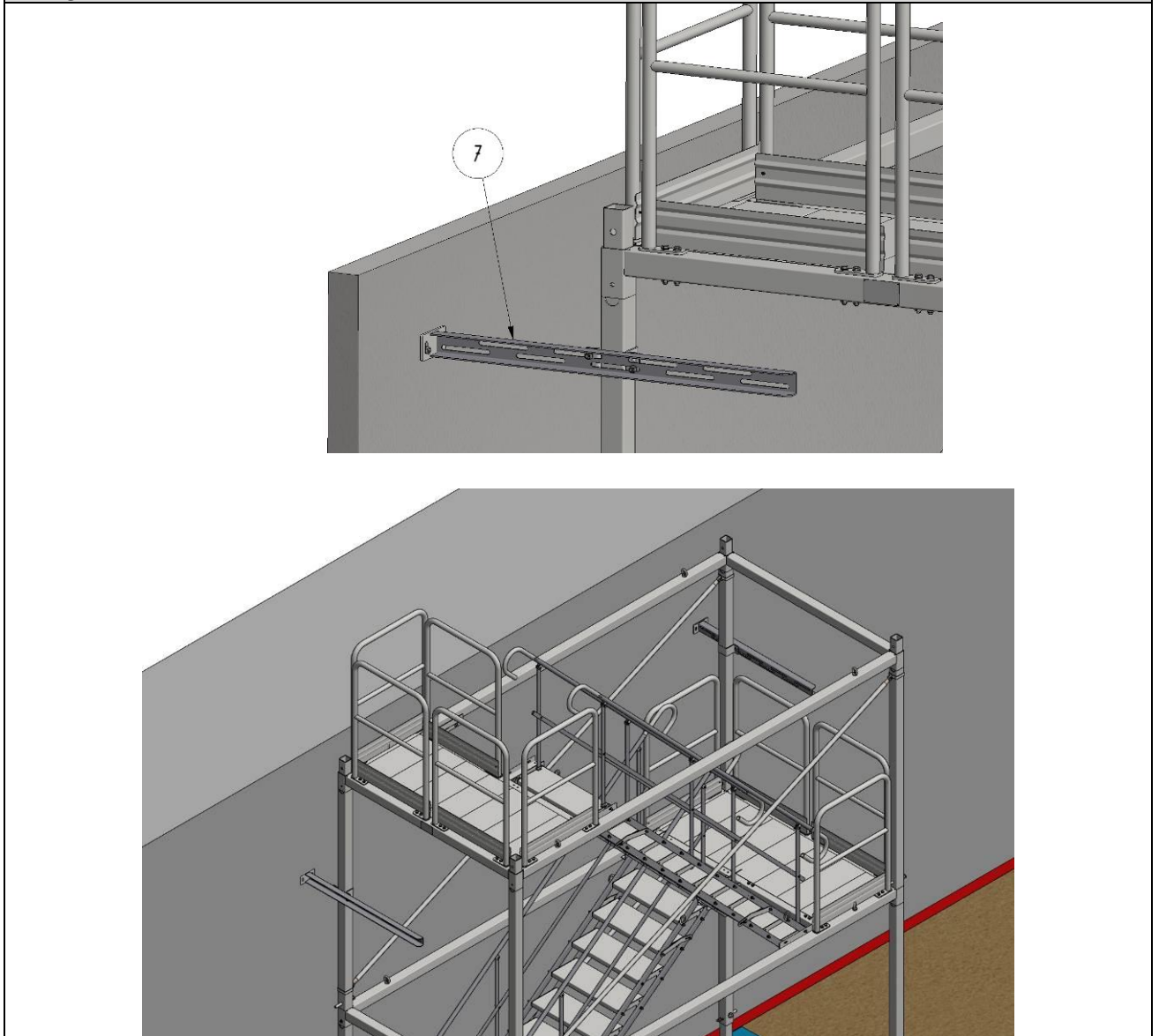

4.4 Assembly of the descent

4.4.1 Assembly when the exit level is above the staircase platform

Level difference when leaving the staircase not exceeding 408 mm - use the TAS-3A stairs

Level difference when leaving the cage not exceeding... mm - use the TAS-6A stairs

WARNING! Check the distance between the staircase and the wall

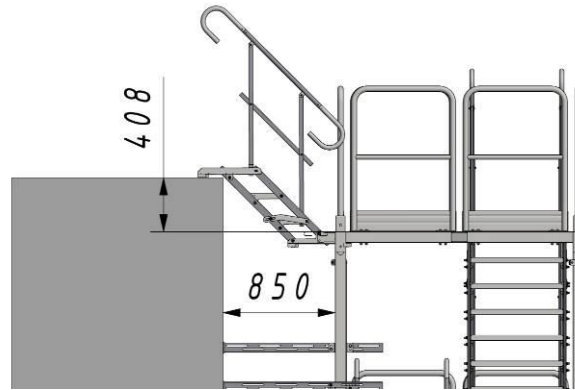

4.4.2 Removal of the bottom foot from the TAS-3A / 6A stairs

The TAS-3A / 6A stairs are equipped with the bottom foot that must be removed before further work

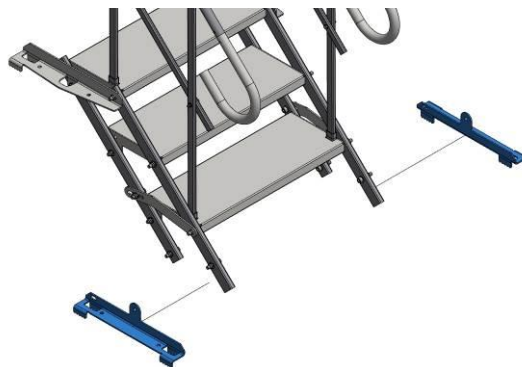

4.4.3 Assembly of the EPS-KS-A5 adapter to the TAS-3A / 6A stairs

The adapter is screwed with the same bolts as the foot

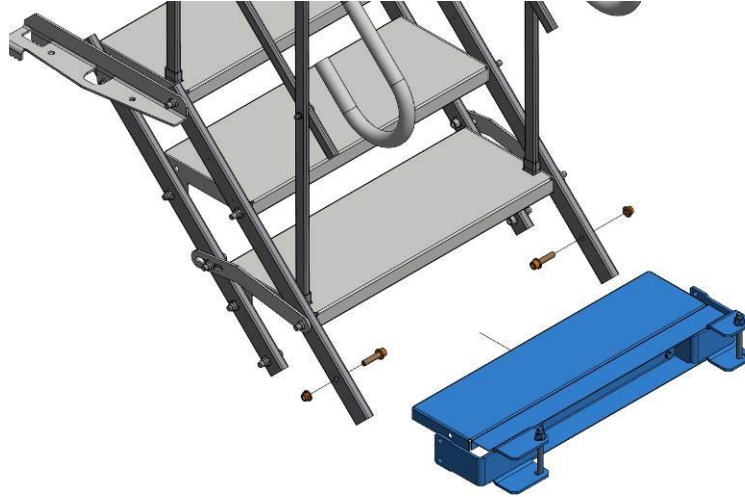

4.4.4 Disassembly of the railing

The railing is disassembled in the reverse sequence to assembly, see item 4.2.2. Assembly of the railings to the frame

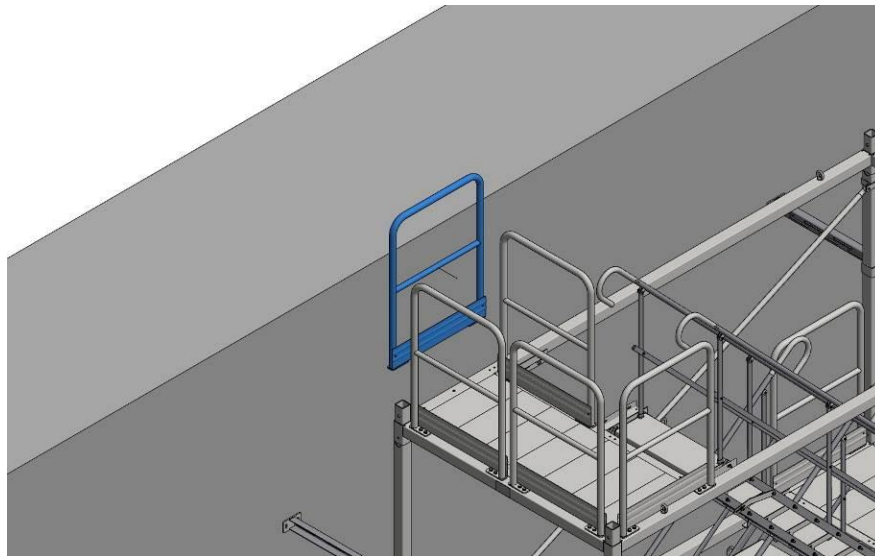

4.4.5 Assembly of the upward descent

The descent is screwed with bolts in the place as the disassembled railing

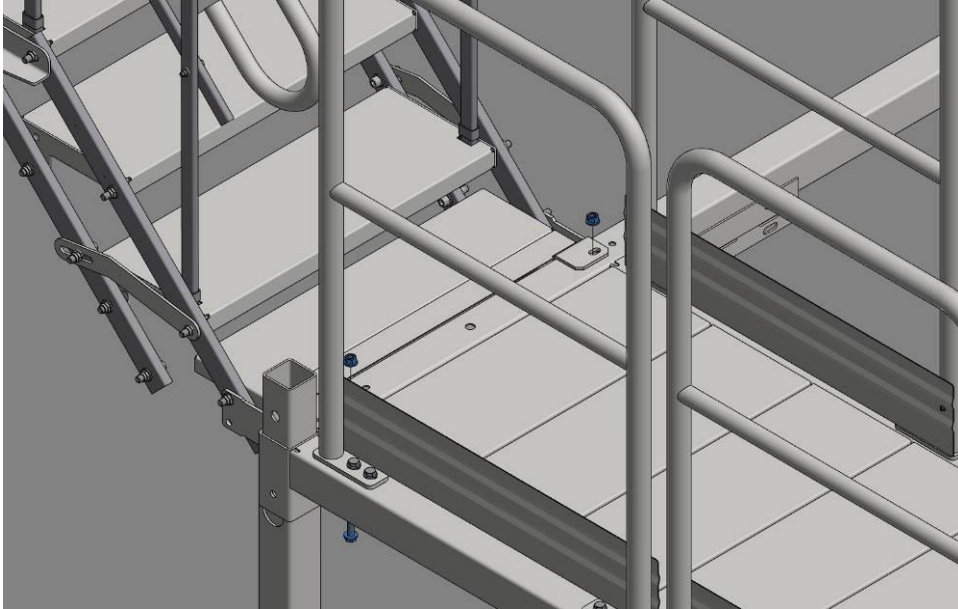

4.4.6 Assembly when the exit level is below the level of the staircase platform

Level difference when leaving the staircase not exceeding 591 mm - use the TAS-3A stairs

Level difference when leaving the staircase not exceeding mm - use the TAS-6A stairs

WARNING! Check the distance between the staircase and the wall

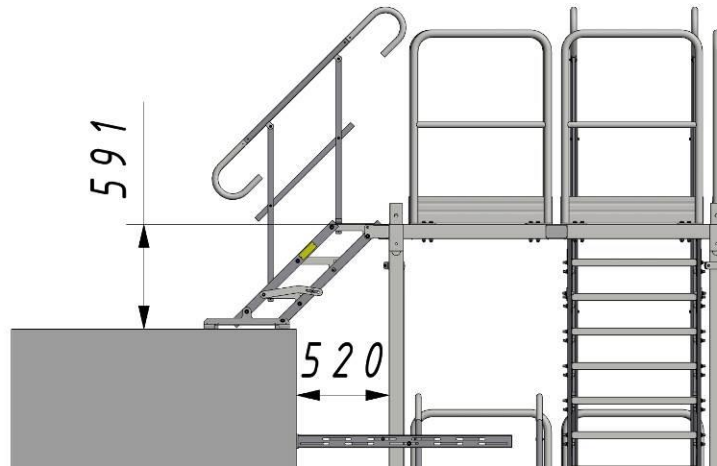

4.4.7 Disassembly of the upper foot from the TAS-3A / 6A stairs

The TAS-3A / 6A stairs are equipped with the upper foot that must be removed before further work

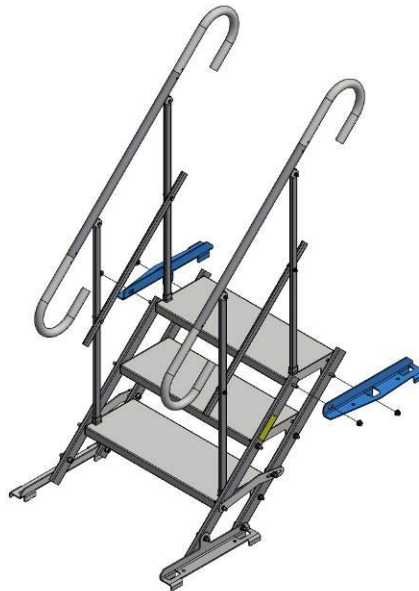

4.4.8 Disassembly of the step from the EPS-KS-A5 adapter

The step must be removed

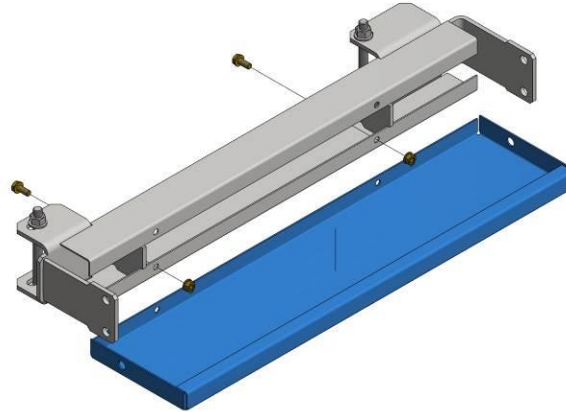

4.4.9 Assembly of the EPS-KS-A5 adapter to the TAS-3A / 6A stairs

The adapter is screwed with the same bolts as the upper foot of stairs.

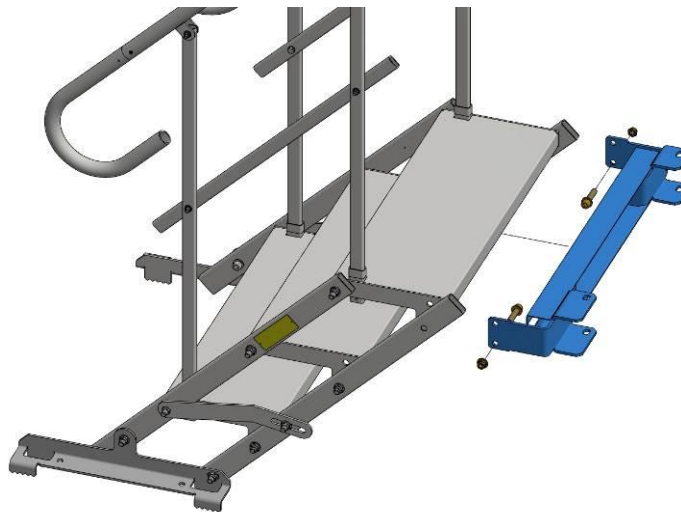

4.4.10 Disassembly of the railing

The railing is disassembled in the reverse sequence to assembly, see item 4.2.2. Assembly of the railings to the frame

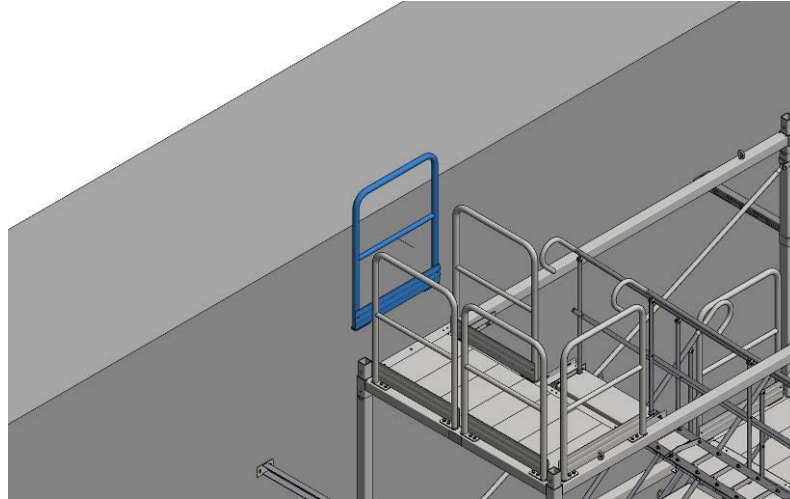

4.4.11 Assembly of the downward descent

The descent is screwed with bolts in the place as the disassembled railing

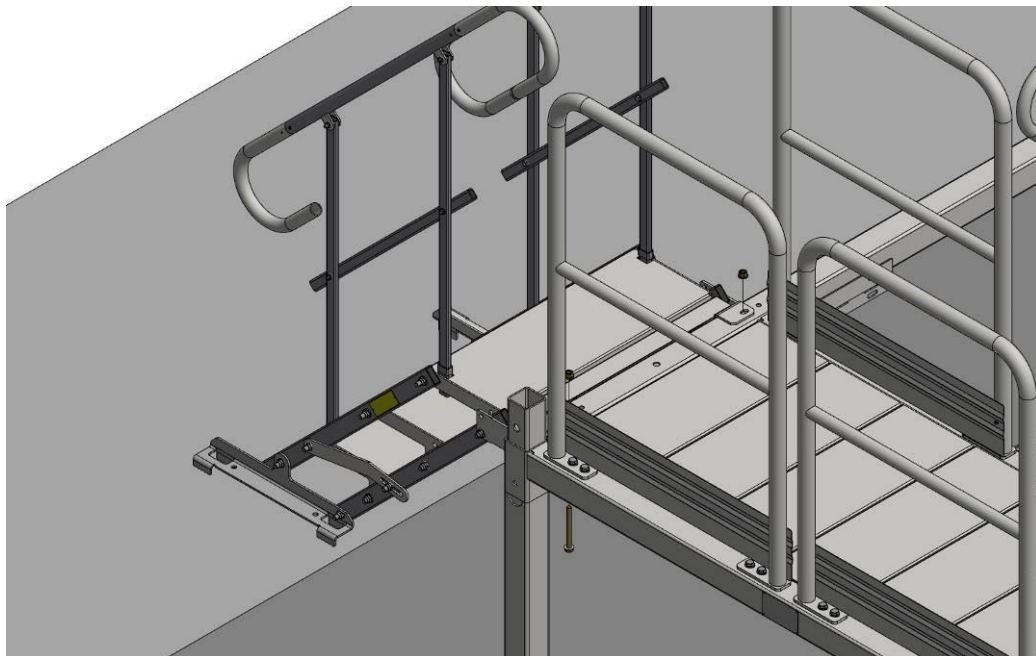

The manufacturer is not responsible for any damage caused by improper assembly of the product or its misuse.