

Appendix no. 1

Assembly manual of

TAS Temporary Stairs

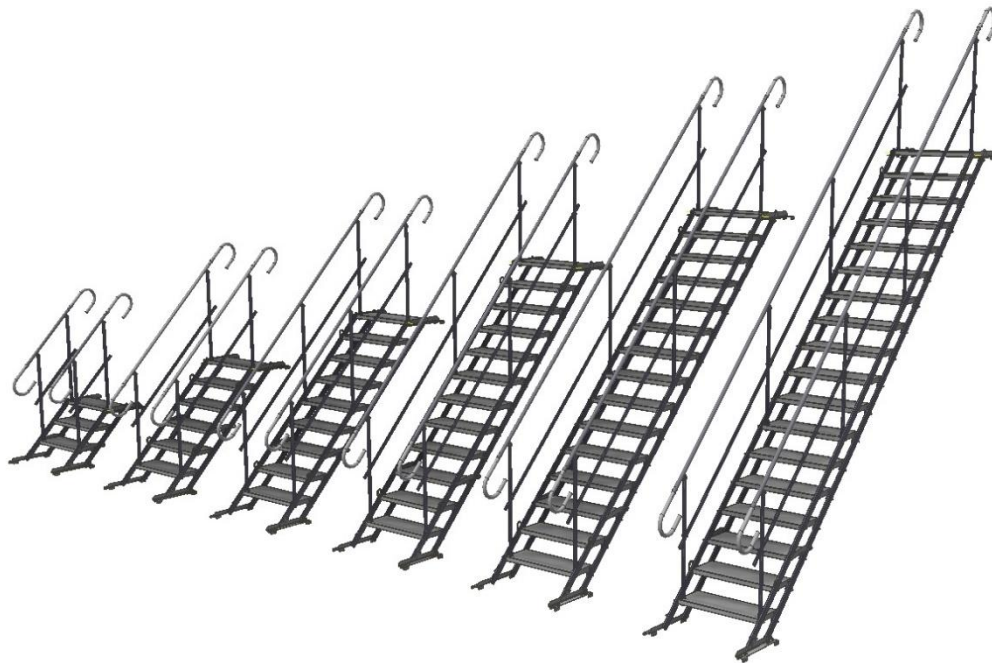

Robert Cieśla

.....
(Prepared by)

Piotr Abram

.....
(Checked by)

Miłosz Muzyka

.....
(Approved by)

Version 8.o, July 2020

Table of Changes

No	FULL NAME	DEPT.	DATE OF CHANGE	SCOPE OF CHANGE	NOTES
1	Robert Cieśła	RD	5.10.2018	Changes in 4. and 5.	
2	Piotr Abram	RD	30.10.2018	Components weight and number of connectors update. Change in 4.4.	
3	Robert Cieśła	RD	29.11.2018	Change in 5.	
4	Robert Cieśła	RD	6.03.2019	Update: TAS-B gangway	
5	Piotr Abram	RD	23.01.2020	Update: TAS-WB truss	
6	Cieśła Robert	RD	23.03.2020	Update: scaffolding coupler	
7	Piotr Abram	RD	22.07.2020	Update – 5.	
8					
9					
10					
11					
12					
13					
14					
15					

Table of content

1. <i>General safety rules</i>	4
2. <i>Components</i>	5
3. <i>List of tools required for TAS stairs assembly</i>	23
4. <i>Assembly of TAS stairs</i>	24
5. <i>Assembly of stairs and gangways</i>	36
6. <i>Operational conditions</i>	38
7. <i>Disassembly</i>	38
8. <i>Disposal</i>	38

1. General safety rules

The assembly manual is a part of operation and maintenance documentation of TAS excavation stairs. The stairs consist of elements fitting the specification added to the delivery.

Prior to the assembly works and operation, one should read this manual. The wrong assembly and usage can lead to health and life threatening danger.

Due to high dimensions of particular components, one should act cautiously during transport, assembly and use of the stairs.

Keep this manual as an information source for stairs users and a service team.

1. Assembly and use of stairs incompatible with the manual can result in a product malfunction and may become a source of a danger.
2. The manufacturer takes no responsibility for any damage that resulted from the improper product assembly or misuse.
3. It is forbidden to modify any of the stairs components.
4. The stairs are intended to be used in industrial conditions i.e. to be used by adults, who consider health and safety rules, are trained and sober.
5. It is forbidden to stand under the stairs when they are being used.
6. It is forbidden to use the stairs by a number of people whose combined weight exceeds the weight allowed on the stairs.
7. The stairs are designed to allow movement of people to lower levels of deep excavations and vice versa. Standing on the steps, as well as putting objects which are not the components of the stairs is against the rules of use.
8. The stairs should not be used to transport other objects than tools, devices etc.
9. Due to the fact that in most cases the stairs are assembled on unpaved ground, one should consider the risk of ground sliding/ wetting which can affect stairs stability.
10. If there's a risk of falling from a height, one should always use safety harness while assembling and disassembling the stairs.

This manual was prepared by TLC Sp. z o. o. and is its property. TLC has all copyrights resulting therefrom.

Without the written consent of TLC Sp. z o. o. it is forbidden to pass the manual to others in whole or in part, to copy and distribute it in whole or in part, to process it in electronic form in whole or in part. The manufacturer reserves the right to make changes to the product without notifying the user.

2. Components

The basic TAS excavation stairs components are flights of stairs with railings. Flights are available in 3, 6, 9, 12, 15, 18 step variants of 700 and 1000 mm width. The variants can be connected using proper connectors and supports.

The system allows to establish a walkway over the obstacle with a platform and either 3- or 6- step flight. It is possible to use the stairs as gangways (e.g. over excavations) with 3, 6, 8, or 12 step stairs, and with 15 and 18 step stairs with an additional truss application.

Exchanging the lower and upper foot of the stairs allows to assemble it on round, fi 48.3 mm scaffolding systems.

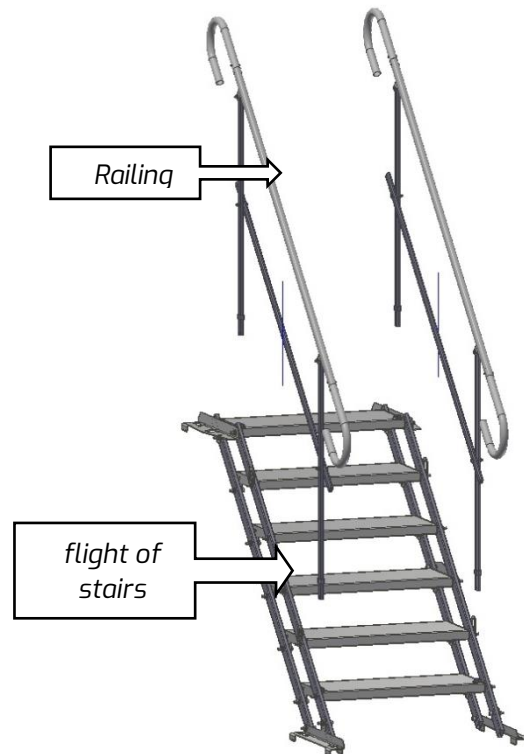

Fig. 1 Components

Tab 1. Stairs IDs (Sets of stairs with railings)

No.	ID	Description
1	TAS-3A	Stairs with 3 steps, width 708 mm
2	TAS-6A	Stairs with 6 steps, width 708 mm
3	TAS-9A	Stairs with 9 steps, width 708 mm
4	TAS-12A	Stairs with 12 steps, width 708 mm
5	TAS-15A	Stairs with 15 steps, width 708 mm
6	TAS-18A	Stairs with 18 steps, width 708 mm
7	TAS-3B	Stairs with 3 steps, width 1000 mm
8	TAS-6B	Stairs with 6 steps, width 1000 mm
9	TAS-9B	Stairs with 9 steps, width 1000 mm
10	TAS-12B	Stairs with 12 steps, width 1000 mm
11	TAS-15B	Stairs with 15 steps, width 1000 mm
12	TAS-18B	Stairs with 18 steps, width 1000 mm

Tab 2. Additional equipment

No.	ID	Description
13	TAS-K3	3 step gangway, width 708 mm
14	TAS-K4	3 step gangway, width 1000 mm
15	TAS-WB1	Truss 01
16	TAS-WB2	Truss 02
17	TAS-WB3	Bar

System components

TAS-S3A

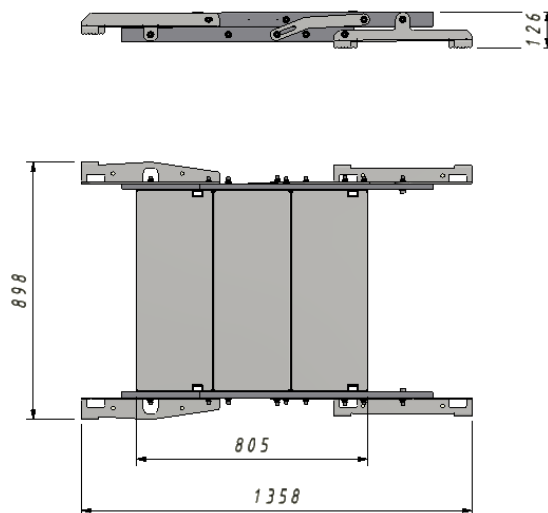

Weight: 31.31 kg

TAS-S3B

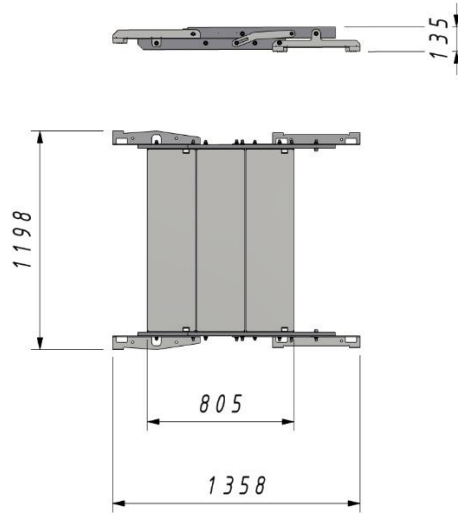

Weight: 40.6 kg

TAS-BP3

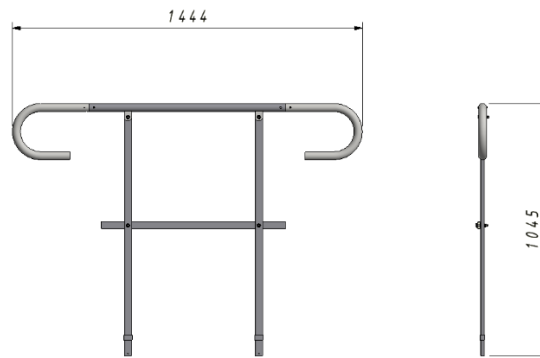

Weight: 8.18 kg

TAS-BL3

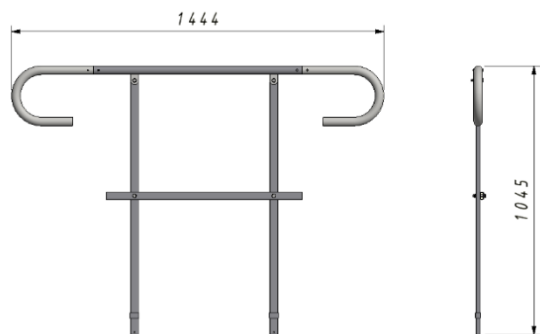

Weight: 8.18 kg

TAS-S6A

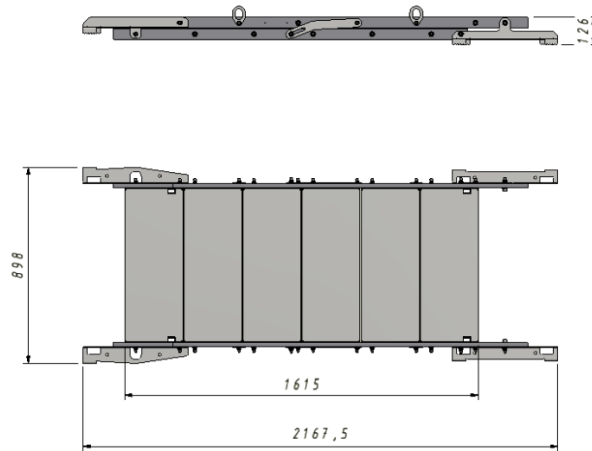

Weight: 53.26 kg

TAS-S6B

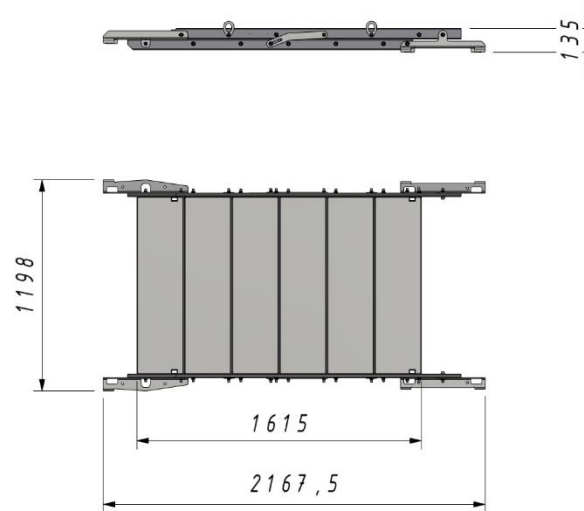

Weight: 71.86 kg

TAS-BL6

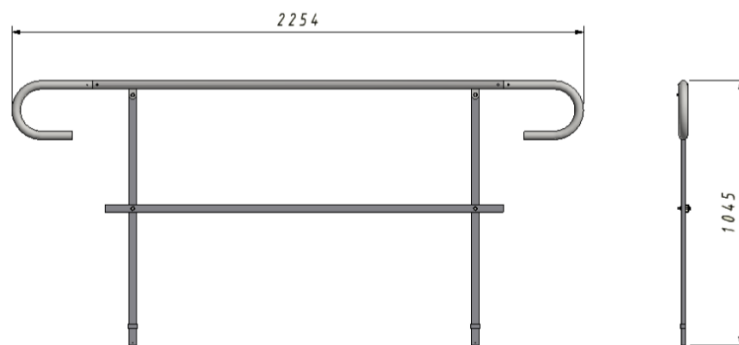

Weight: 10.96 kg

TAS-BP6

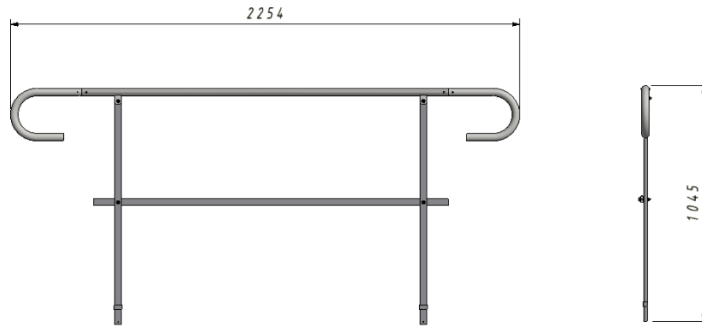

Weight: 10.96 kg

TAS-S9A

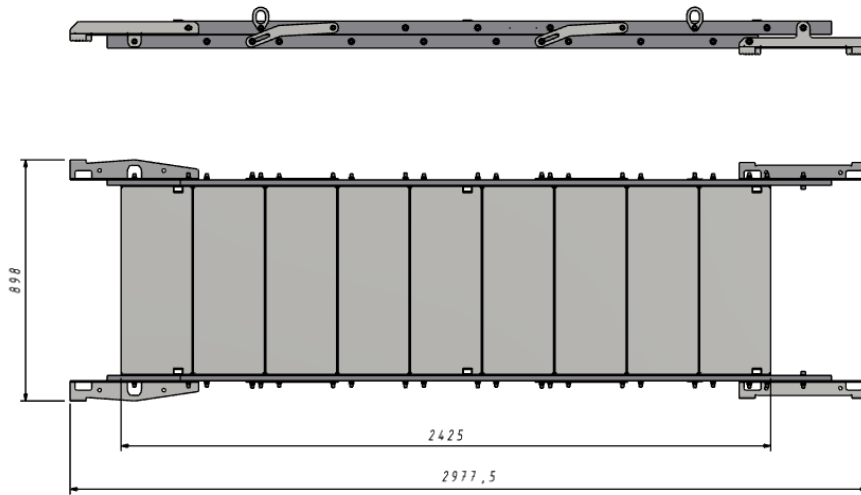

Weight: 76.45 kg

TAS-S9B

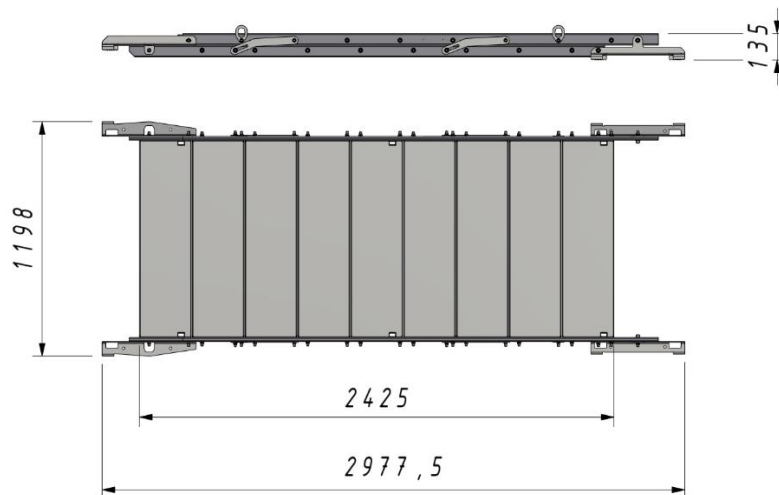

Weight: 104.4 kg

TAS-BL9

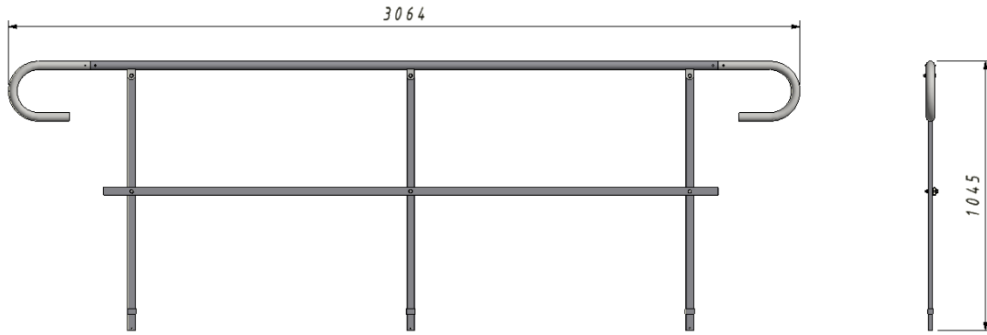

Weight: 15.1 kg

TAS-BP9

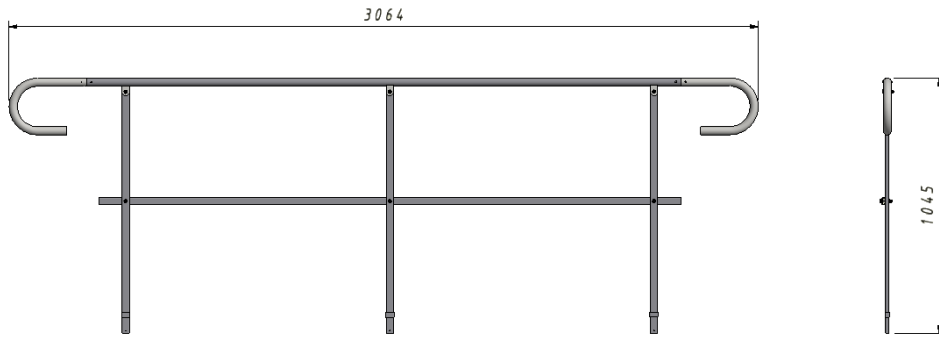

Weight: 15.1 kg

TAS-S12A

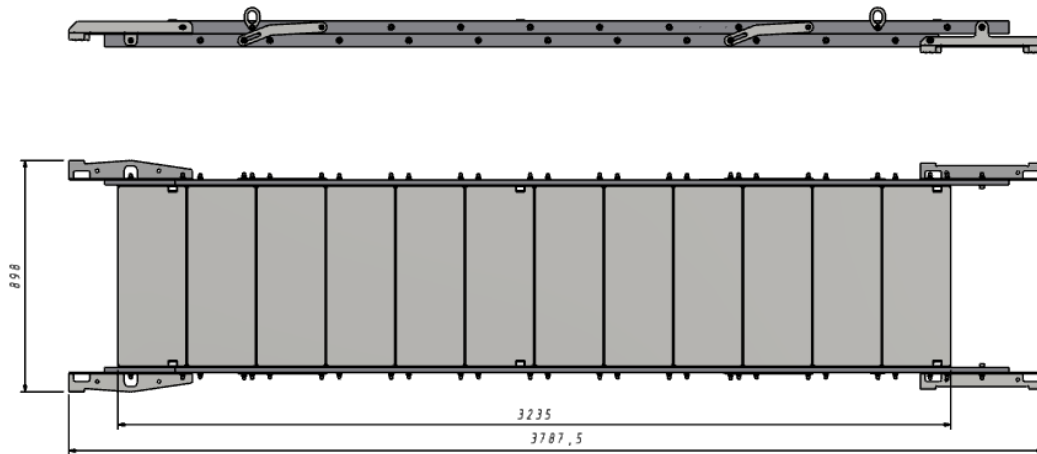

Weight: 98.18 kg

TAS-S12B

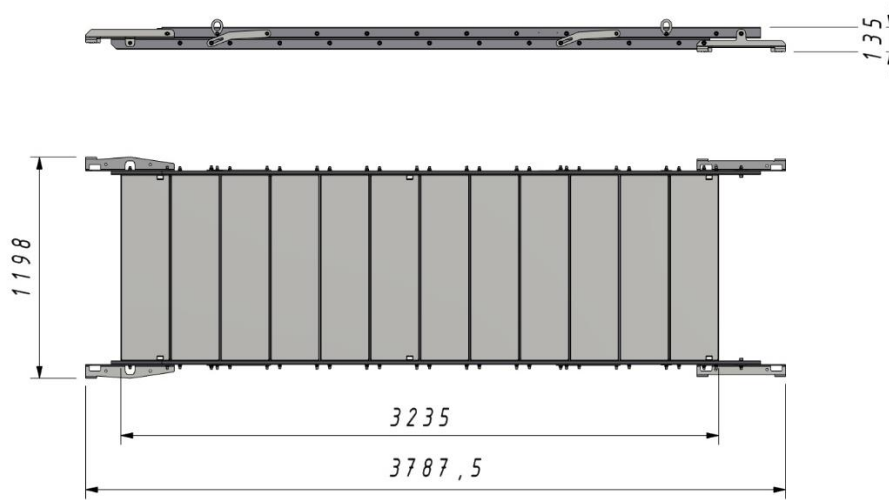

Weight: 135.5 kg

TAS-BL12

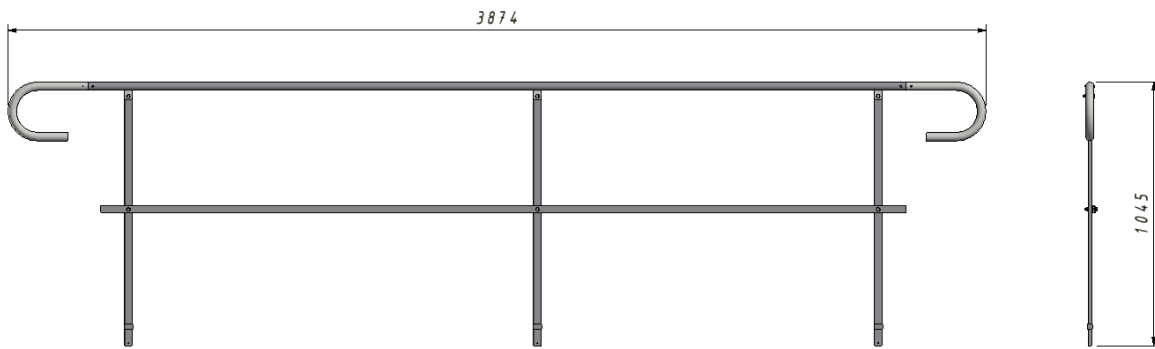

Weight: 17.9 kg

TAS-BP12

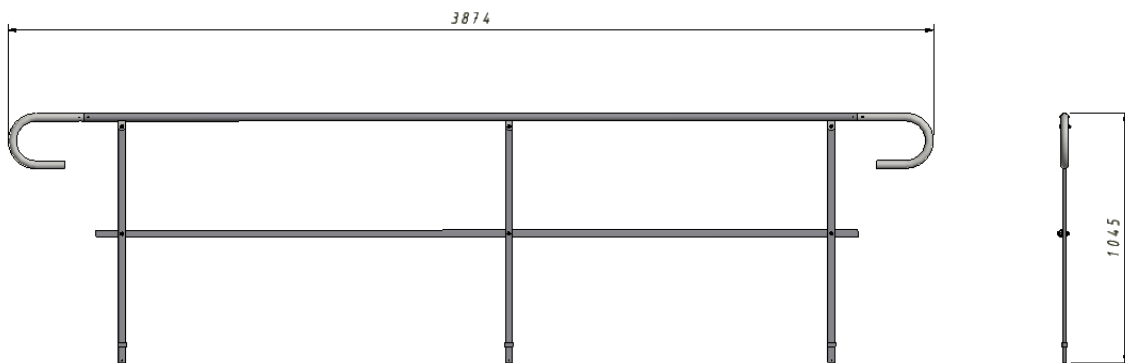

Weight: 17.9 kg

TAS-S15A

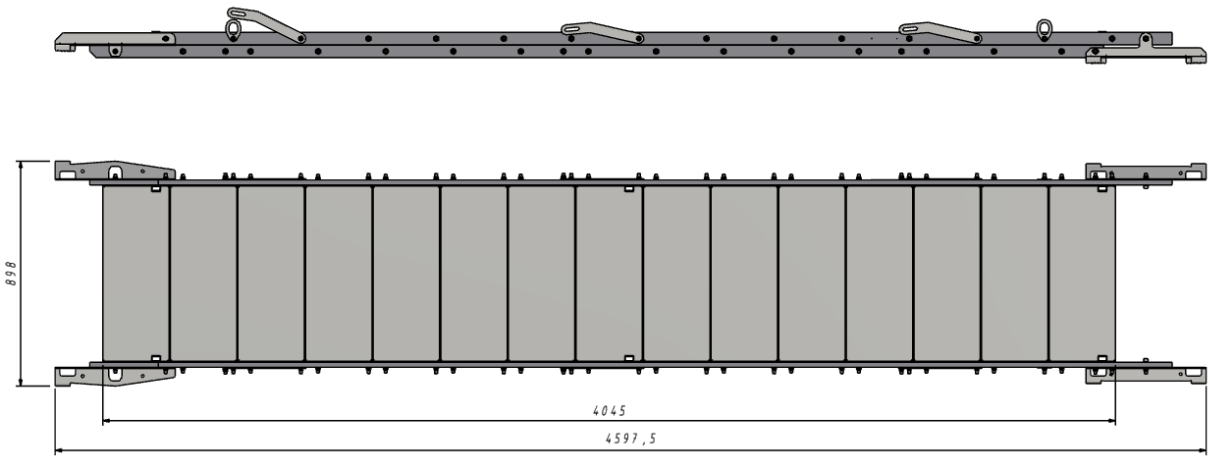

Weight: 120.93 kg

TAS-S15B

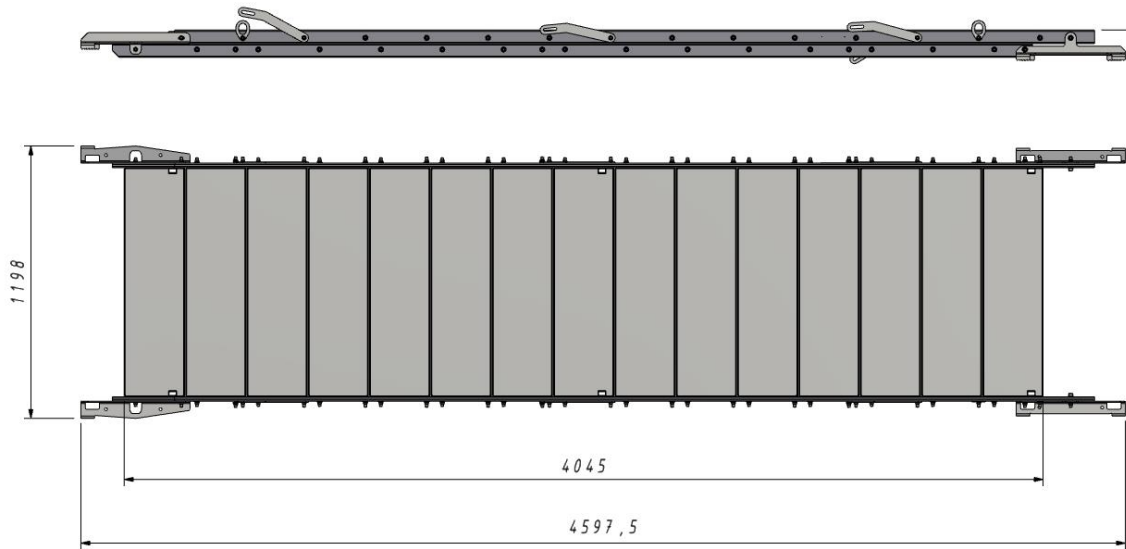

Weight: 167.64 kg

TAS-BL15

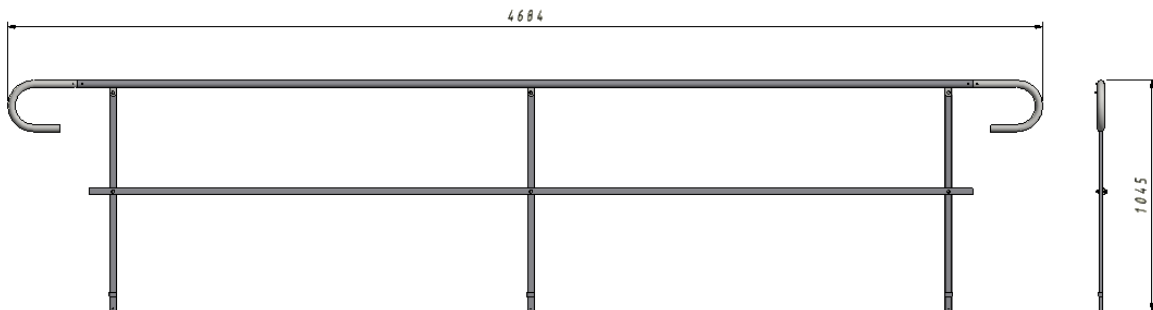

Weight: 20.67 kg

TAS-BP15

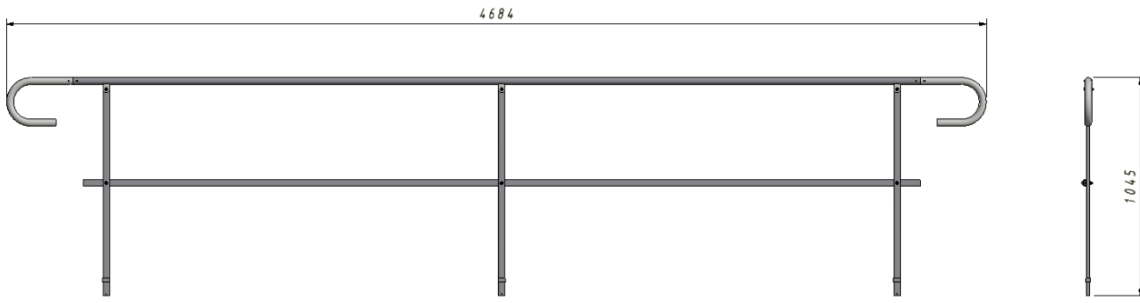

Weight: 20.67 kg

TAS-S18A

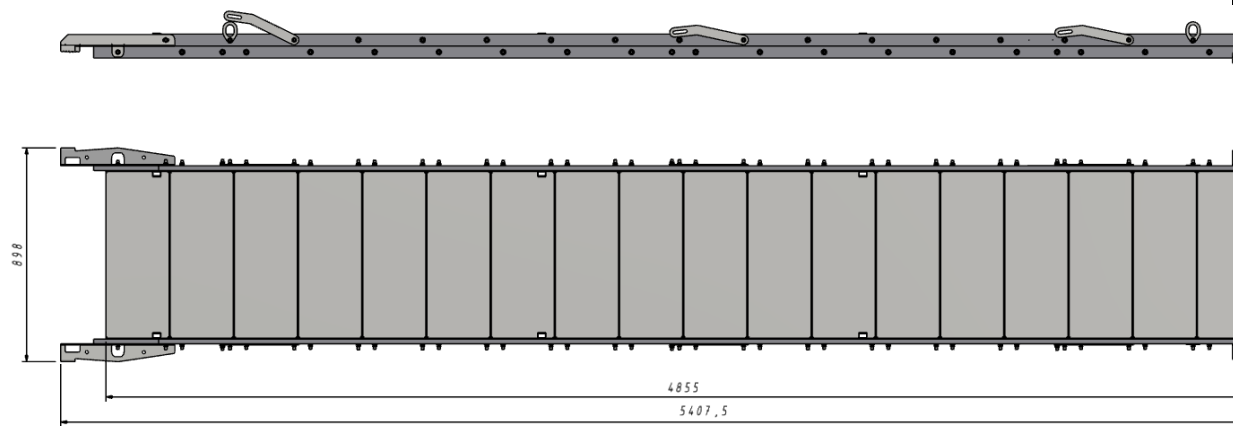

Weight: 142.97 kg

TAS-S18B

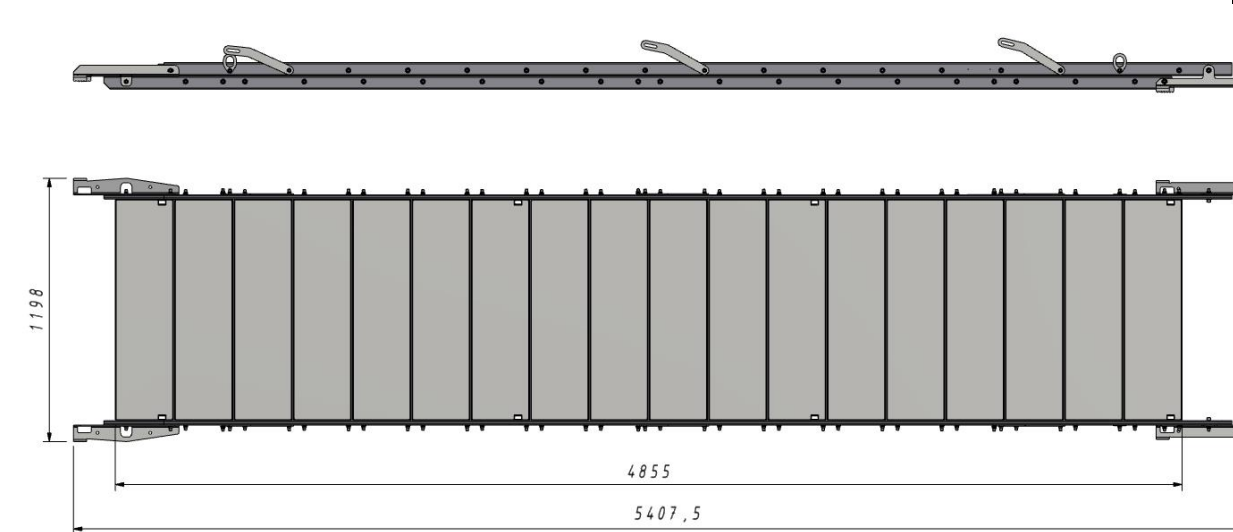

Weight: 199 kg

TAS-BL18

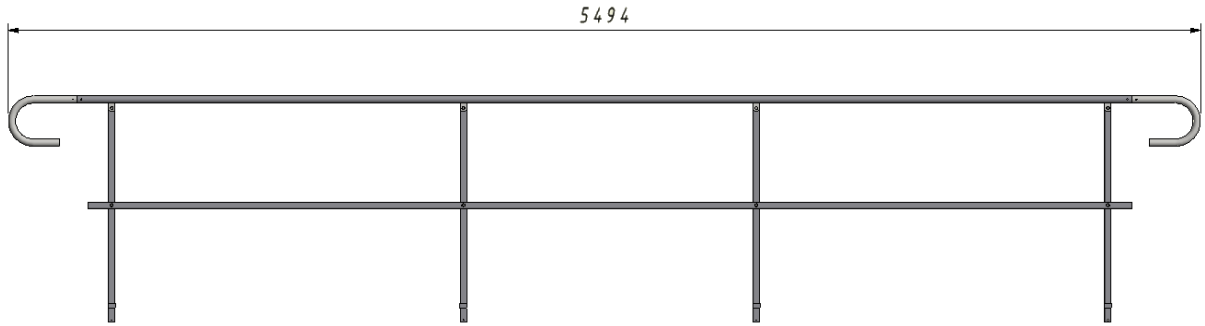

Weight: 24.81 kg

TAS-BP18

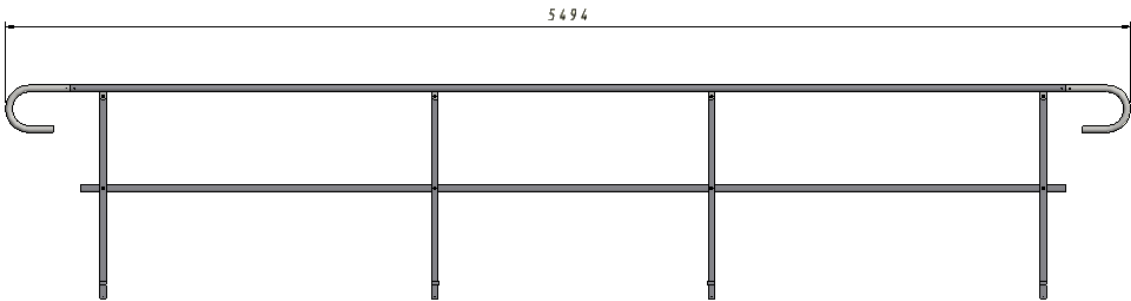

Weight: 24.81 kg

TAS-L5

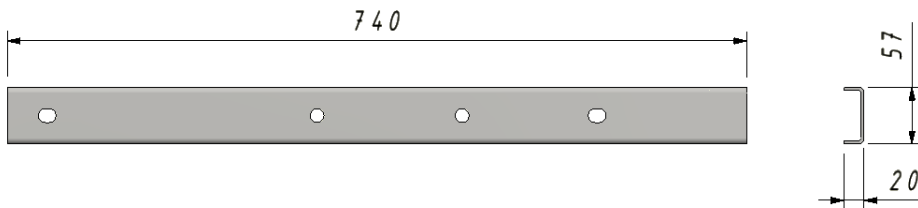

Weight: 2.7 kg

TAS-L6

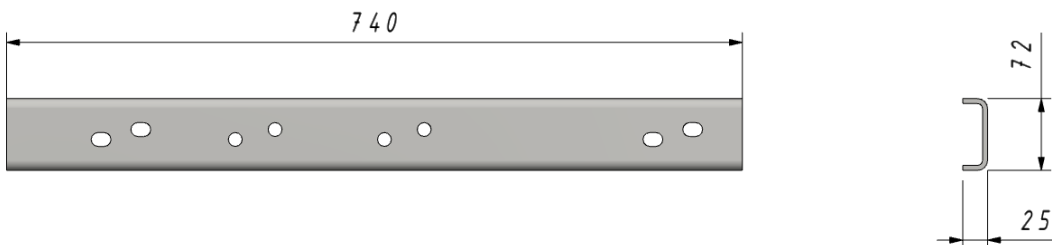

Weight: 3 kg

TAS-PR1

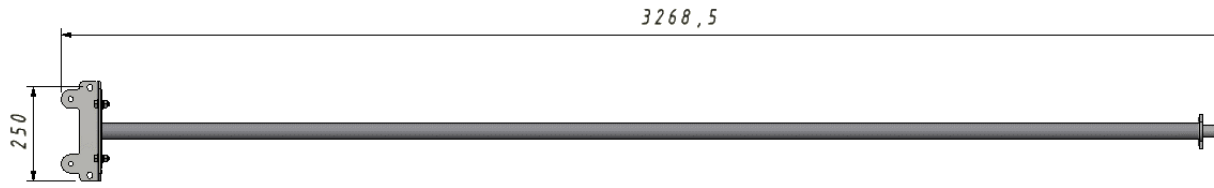

Weight: 10.28 kg

TAS-K4

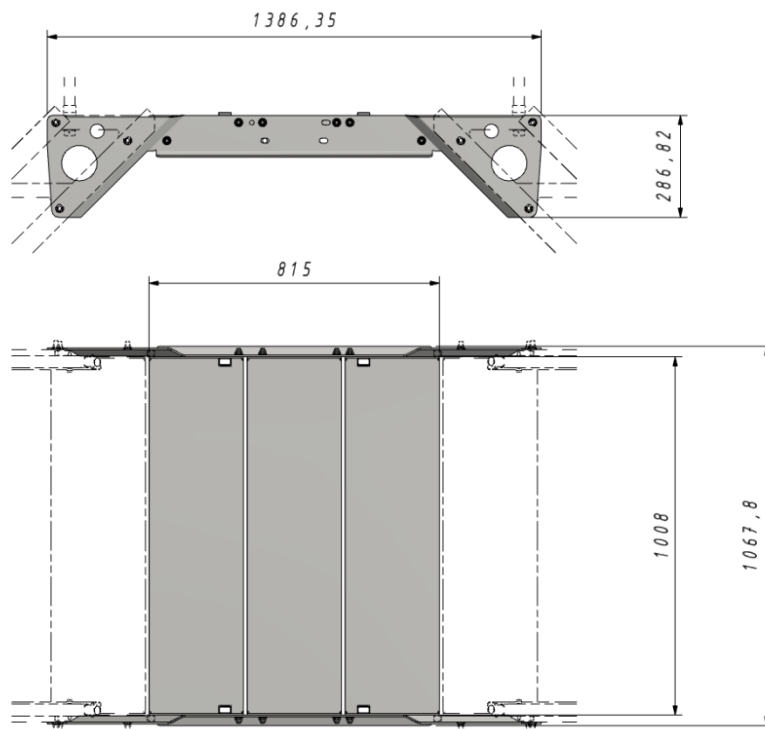

Weight: 50 kg

TAS-K3

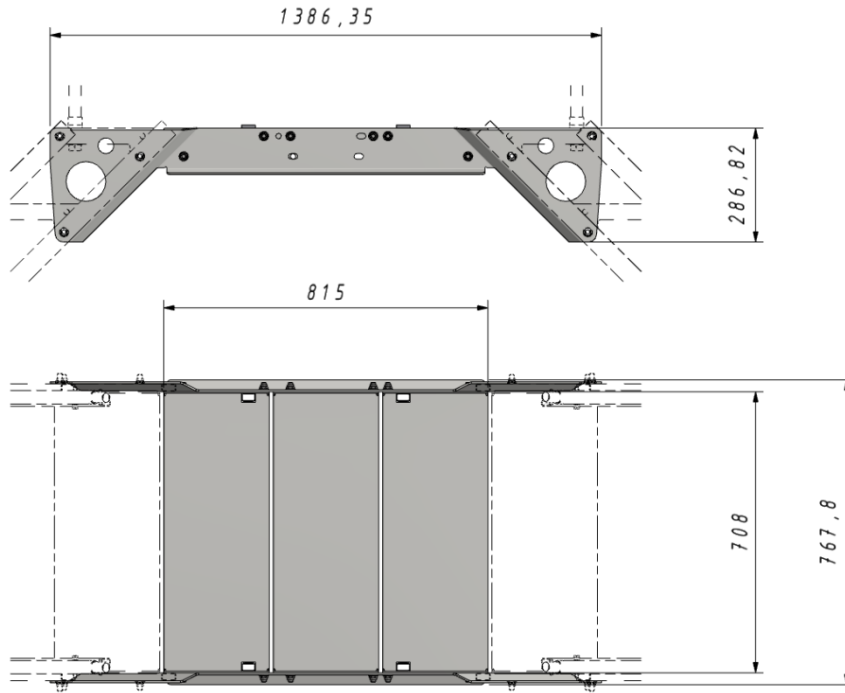

Weight: 45 kg

TAS-PH3

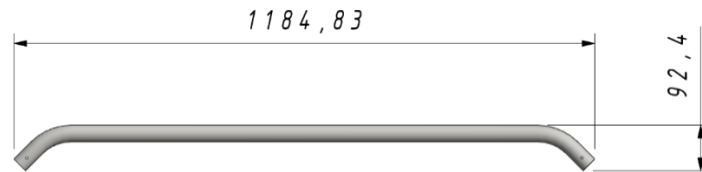

Weight: 2.4 kg

TAS-PR3



Weight: 1.6 kg

D-TAS-064

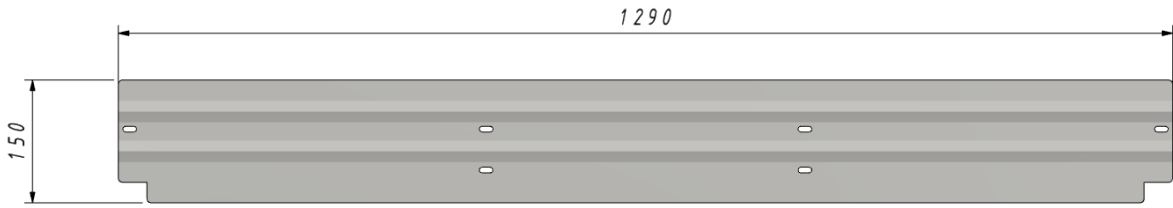

Weight: 2.27 kg

D-TAS-063

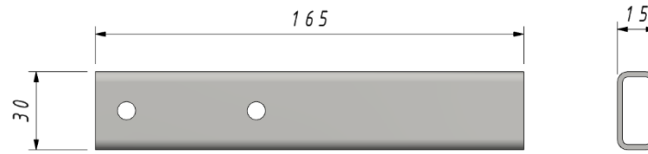

Weight: 0.2 kg

TAS-WB1

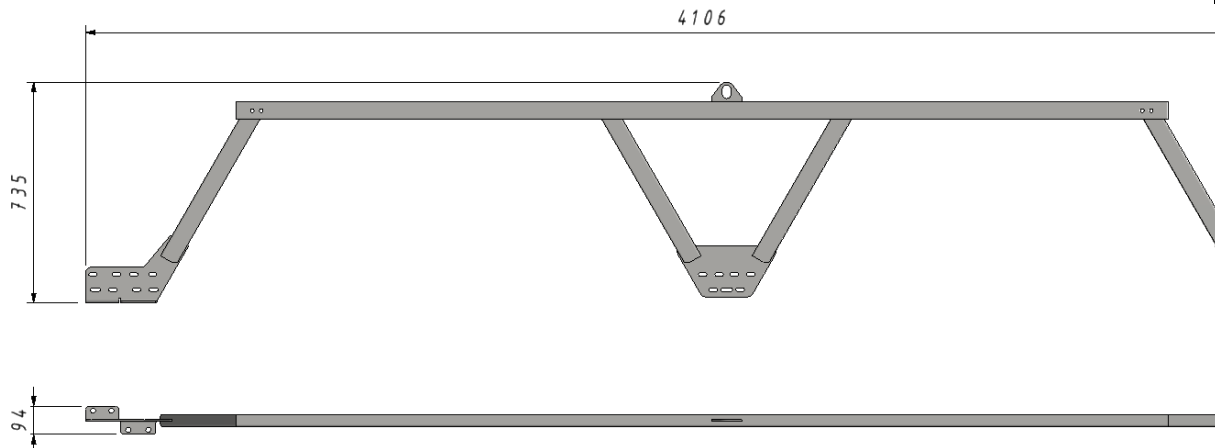

Weight: 28.5 kg

TAS-WB2

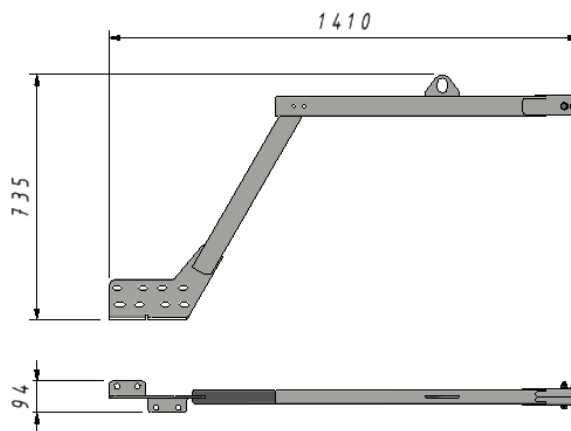

Weight: 8.9 kg

TAS-WB3

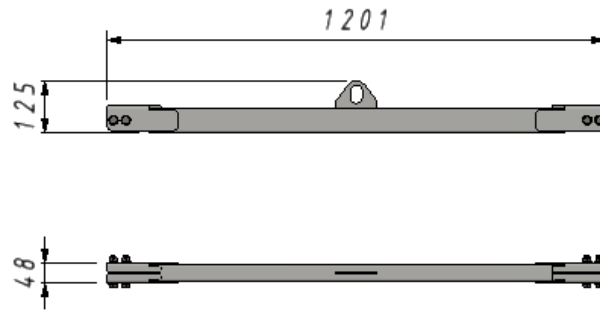

Weight: 6.2 kg

TAS-PR4

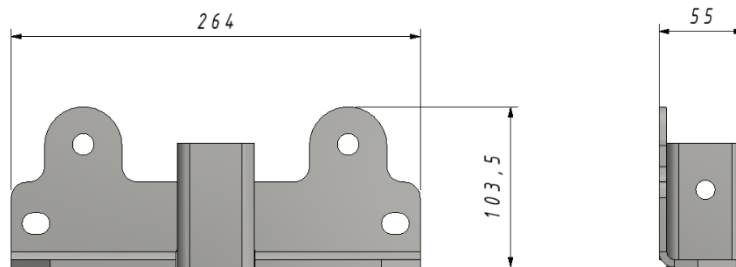

Weight: 1.6 kg

TAS-L15

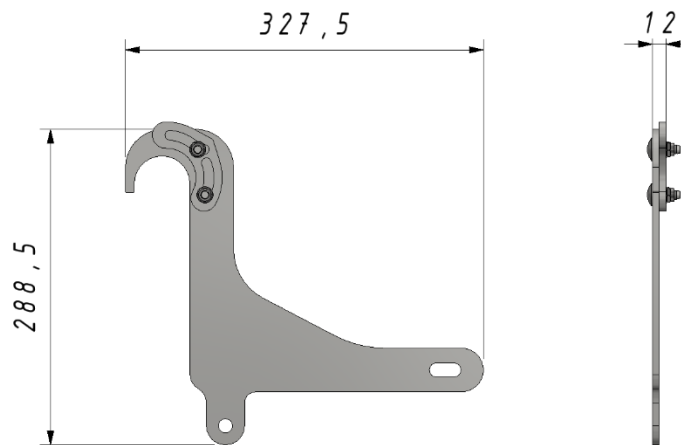

Weight: 1.3 kg

TAS-L14

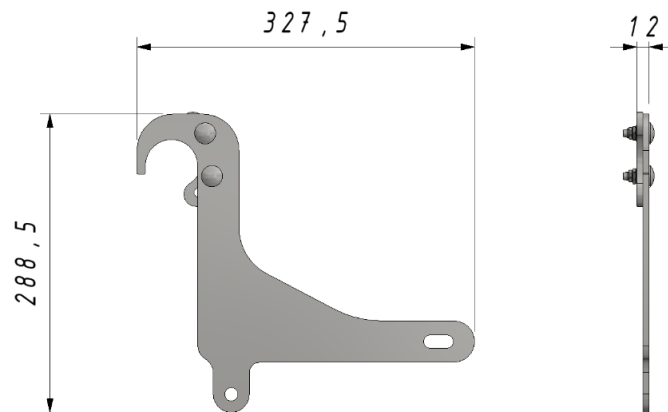

Weight: 1.3 kg

TAS-L16

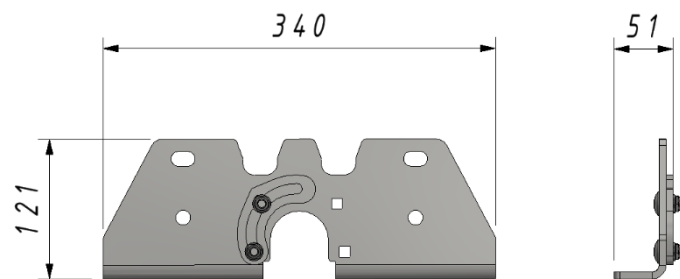

Weight: 2.1 kg

TAS-L17

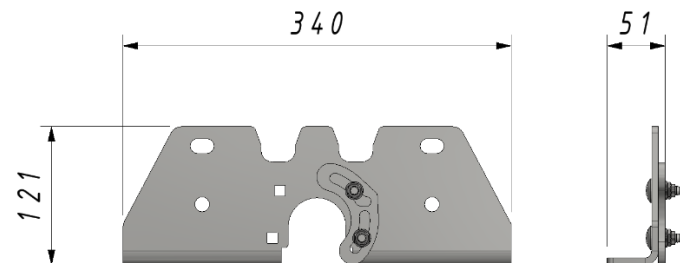

Weight: 2.1 kg

TAS-BU

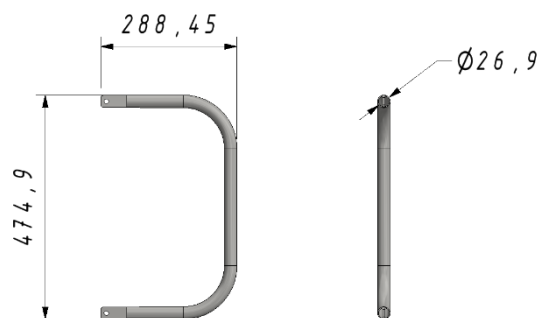

Weight: 1.2 kg

TAS-BL12H

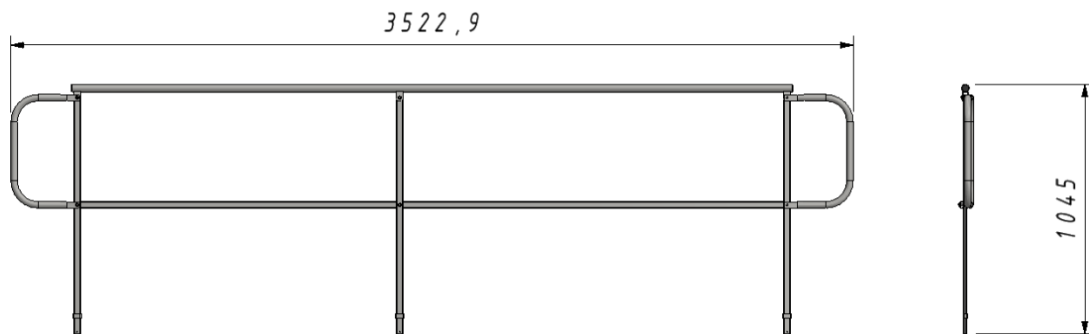

Weight: 16.5 kg

TAS-BP12H

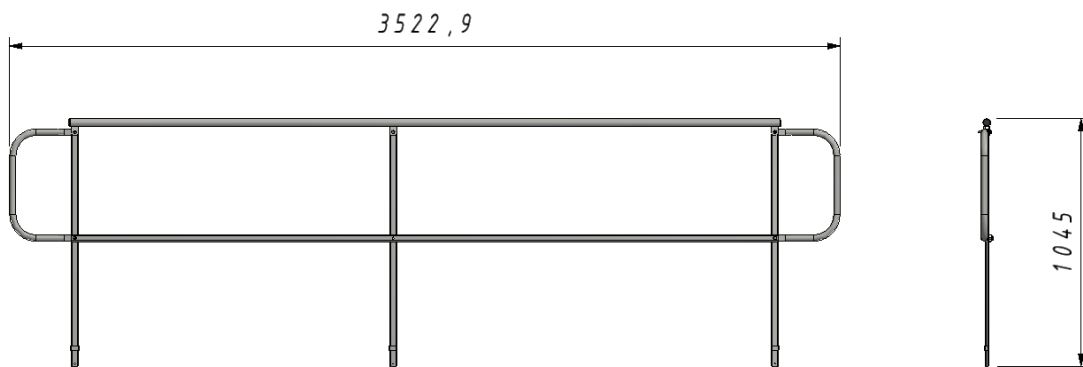

Weight: 16.5 kg

Tab 3. The list of fasteners

No.	Fasteners	TAS-3	TAS-6	TAS-9	TAS-12	TAS-15	TAS-18
		A/B	A/B	A/B	A/B	A/B	A/B
1	Bolt ISO 4762 8-ZN - M12 x 25	4	4	6	6	6	8
2	Nut ISO 4032 8-ZN - M12	4	4	6	6	6	8
3	Washer ISO 7089 ZN-12 - 200 HV	18	30	44	56	70	82
4	Bolt ISO 7380 8-ZN M12 x 50	18	30	44	56	70	82
5	Nut ISO 10511 ZN - M12	18	30	44	56	70	82
6	Screw DIN 7504K 4,2x16 Galvanized	8	8	8	8	8	8
7	Washer ISO 7089 ZN-8 - 200 HV	16	16	24	24	24	32
8	Bolt ISO 4014 8-ZN - M8 x 45	4	4	6	6	6	8
9	Nut ISO 10511 ZN - M8	8	8	12	12	12	16
10	Bolt ISO 4014 8-ZN - M8 x 40	4	4	6	6	6	8

Tab 4. The list of fasteners for additional equipment

No.	Fasteners	TAS-K3	TAS-K4
11	Nut ISO 4032 8-ZN - M12	4	4
12	Nut ISO 10511 ZN - M12	12	12
13	Nut ISO 4032 8-ZO - M6	8	8
14	Nut ISO 10511 ZN - M8	4	4
15	Washer ISO 7089 ZN-12 - 200 HV	24	24
16	Washer ISO 7089 ZO-6 - 200 HV	16	16
17	Washer ISO 7089 ZN-8 - 200 HV	8	8
18	Bolt ISO 4762 8-ZN - M12 x 25	4	4
19	Bolt ISO 4762 8-ZN - M12 x 30	12	12
20	Bolt ISO 4017 8-ZO - M6 x 30	8	8
21	Bolt ISO 4014 8-ZN - M8 x 65	4	4

Tab 5. Components required to create TAS-15 and TAS-18 stairs

Index/ Set	15	15+15	15+18	18+18	18
TAS-15 A/B	1	2	1	0	0
TAS-18 A/B	0	0	1	2	1
TAS-WB1	2	4	4	4	2
TAS-WB2	0	0	2	4	2
TAS-WB3	0	2	2	2	0







Tab 6. MA torque for class 8.8 bolts

Diameter	Torque in Nm
M8	23
M10	46
M12	79

Approximate torque values for large thread bolts for friction coefficient $\mu = 0,15$

3. The list of tools required for stairs assembly

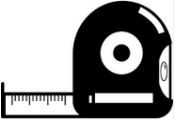
Tab 7. List of tools

	<p><i>Wrenches: 19, 18, 13, 10</i></p>
	<p><i>Wrenches: 8, 10</i></p>
	<p><i>Screwdriver</i></p>
	<p><i>Level</i></p>
	<p><i>Tape measure</i></p>
	<p><i>Lifter with at least 1 t capacity when assembling long sets</i></p>

4. Assembly of TAS stairs

The method and the sequence of TAS stairs assembly are presented below:

4.1. Assembly of railings on stairs – insert railing posts into the holes in steps.



4.2. Tightening the railing lock – tighten the bolts (no.1) under the stairs inside the step holes

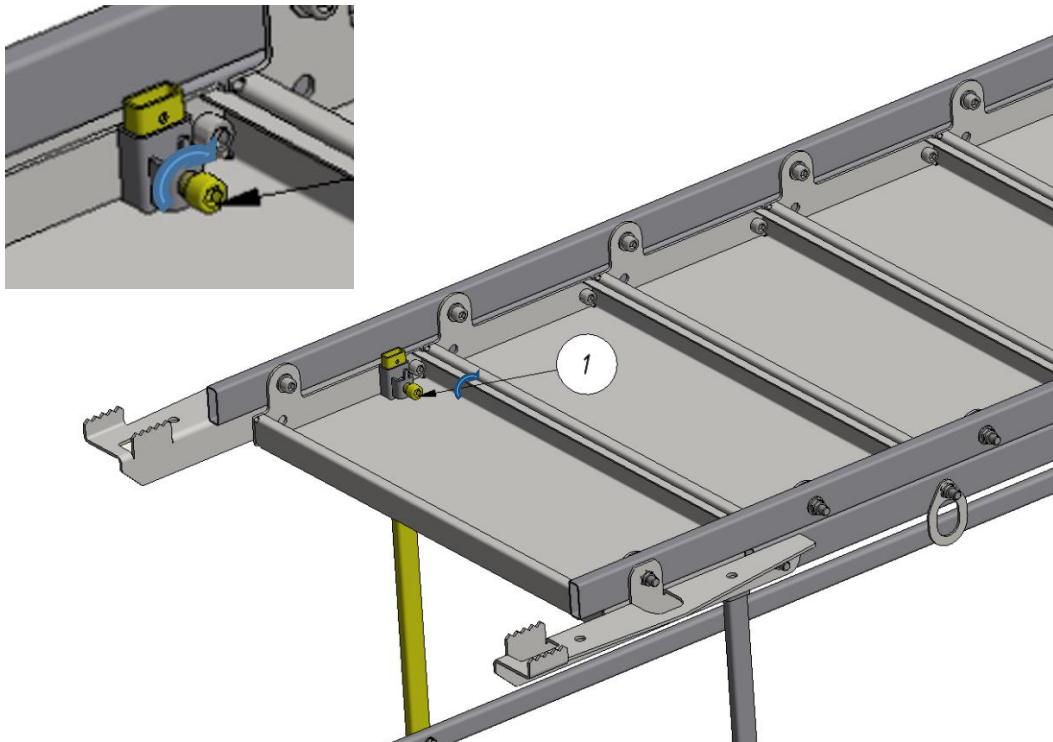

4.3. For 15- and 18-steps tighten the lock which is unlocked for transport. Unbolt the bolt (no.4) with the washer (no.3), insert into the other side of the lock (oblong hole), tighten it up.

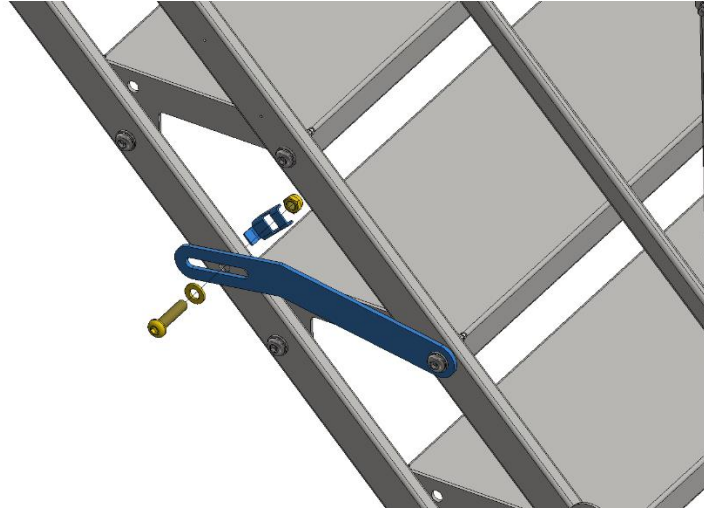

4.4. In order to ensure the stiffness of the stairs, tighten up the bolts fixing the lock. Tighten the connection with 60% of torque intended for the diameter and class of the connector (see table 5.).



4.5. Connecting the stairs

4.5.1. Disassembly of railing ends – unbolt the screws that fix the ends of the railing on both sides of one end of the stairs. Disassemble a lower end in one flight of stairs, and upper end in the other one.

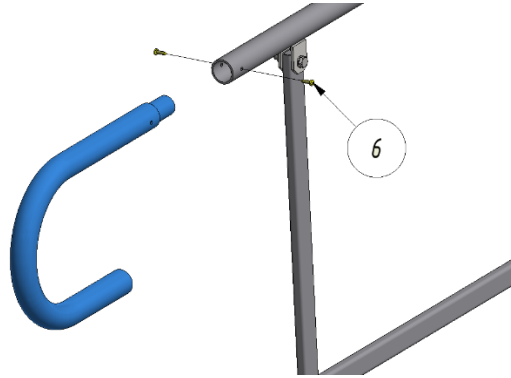

4.5.2. Disassembly of stairs foot – unbolt the bolt connections (no. 3,4,5), which fix the foot with the stringer. Disassemble the lower foot in one flight of stairs and the upper foot in the other one.

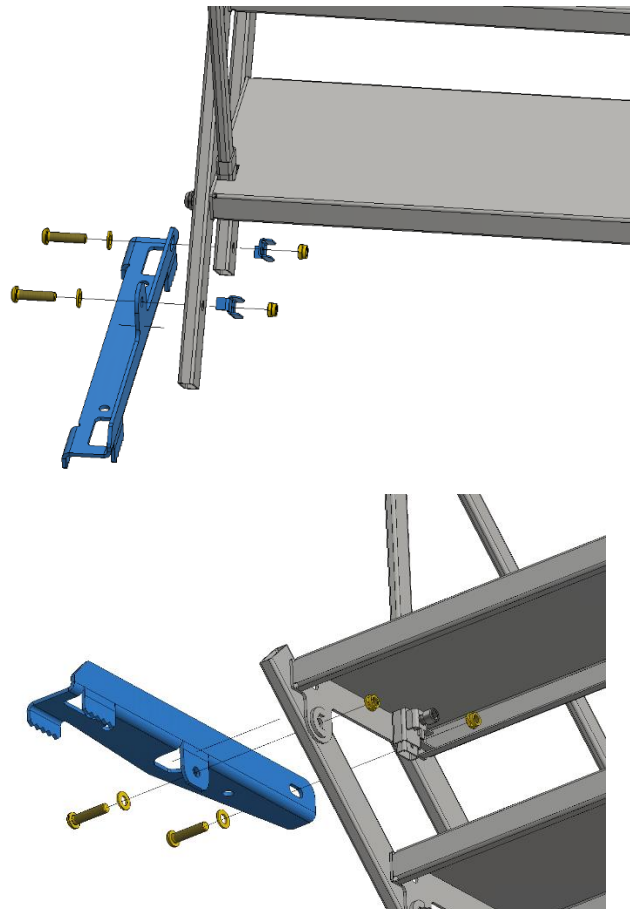

4.5.3. Assembly of a L5/L6 connector – spread the stairs and put one next to another, previously disassembling the foot. Unbolt the bolts fixing the last but one step, whose upper side is being connected with the last step of the second flight. Insert four L5 connectors into the stringer and tighten up all the bolt connectors (no. 3,4,5) – 16 pcs.

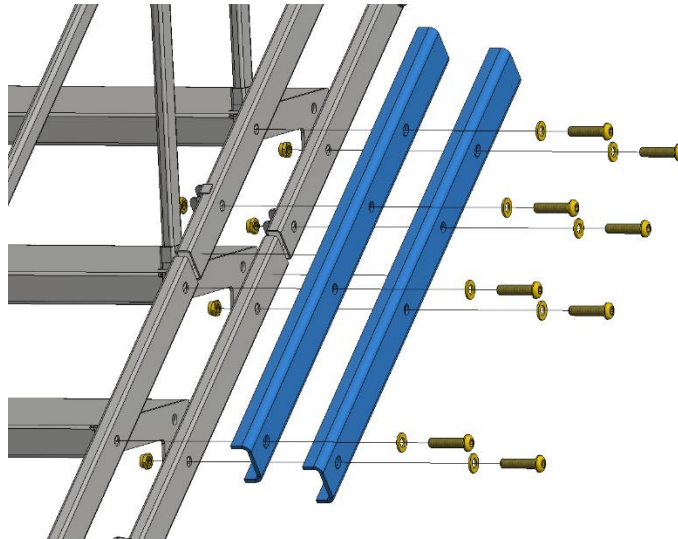

4.6. Assembly of PR1 / PR4 supports – in case of the requirement to support the set of stairs, unbolt the bolt connections fixing the step (no. 3,4,5), put the fixing bracket that fastens the PR1 support, pass the bolt (4) with the washer (3) through the fixing bracket and fasten the nut (5).

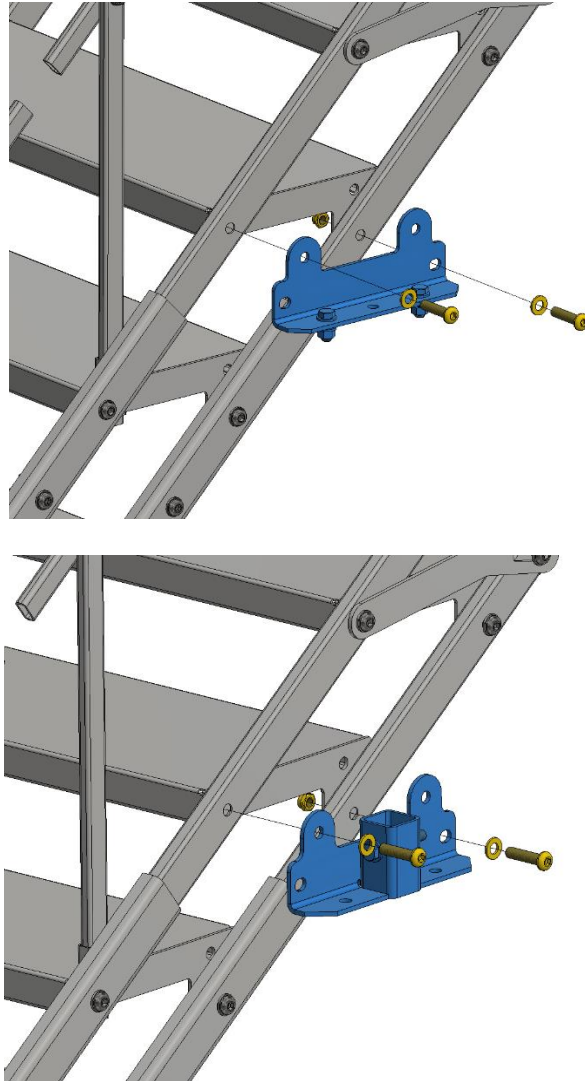

4.7. Step-over platform assembly

4.7.1. Flight of stairs components disassembly:

1. Disassemble the upper foot (see 4.5.2)
2. Disassemble the upper end of the railing (see 4.5.1)

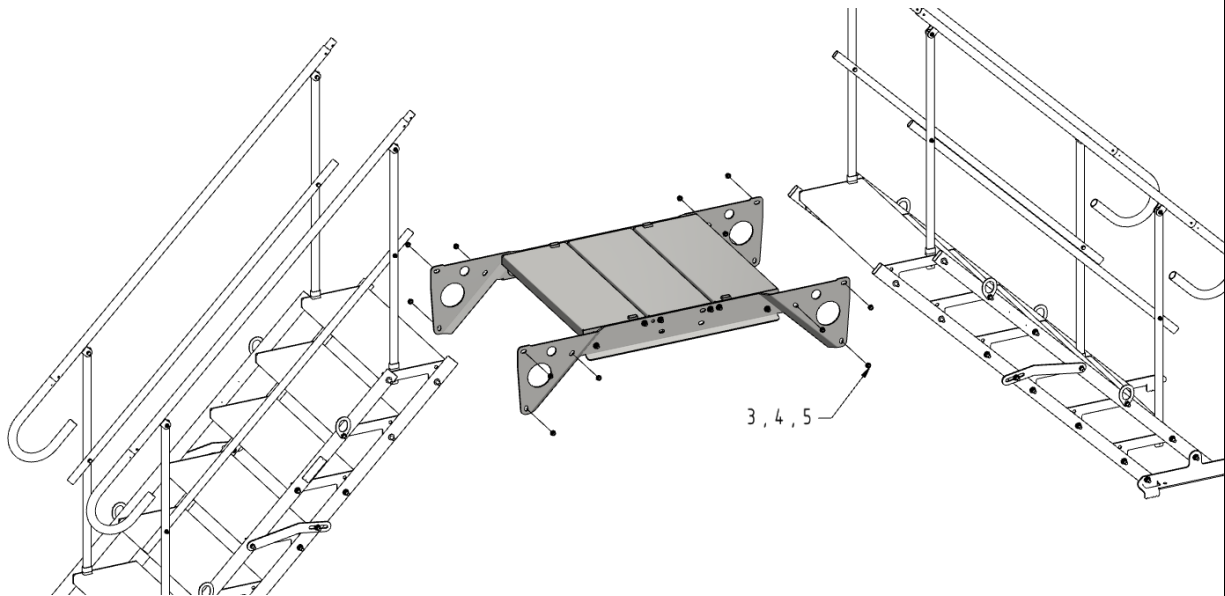

4.7.2. The handrail assembly- slide a handrail onto the railing ends and tighten up with screws.

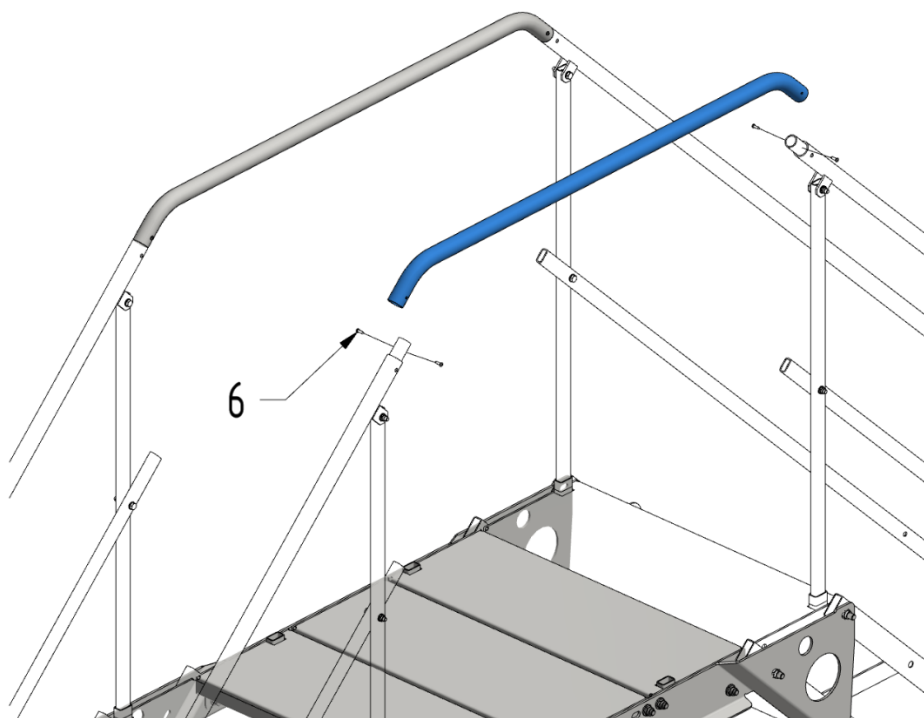

4.7.3. Bar assembly – the bar is assembled to the stairs posts.

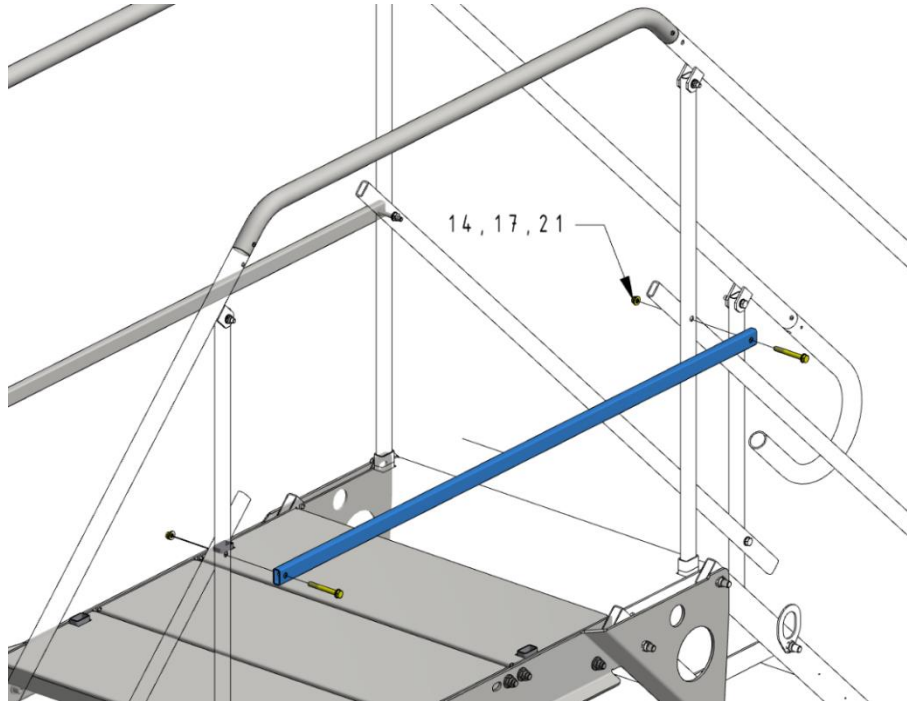

4.7.4. Toe board assembly – Fasten toe boards to D-TAS-063 and slide into the holes inside the platform.

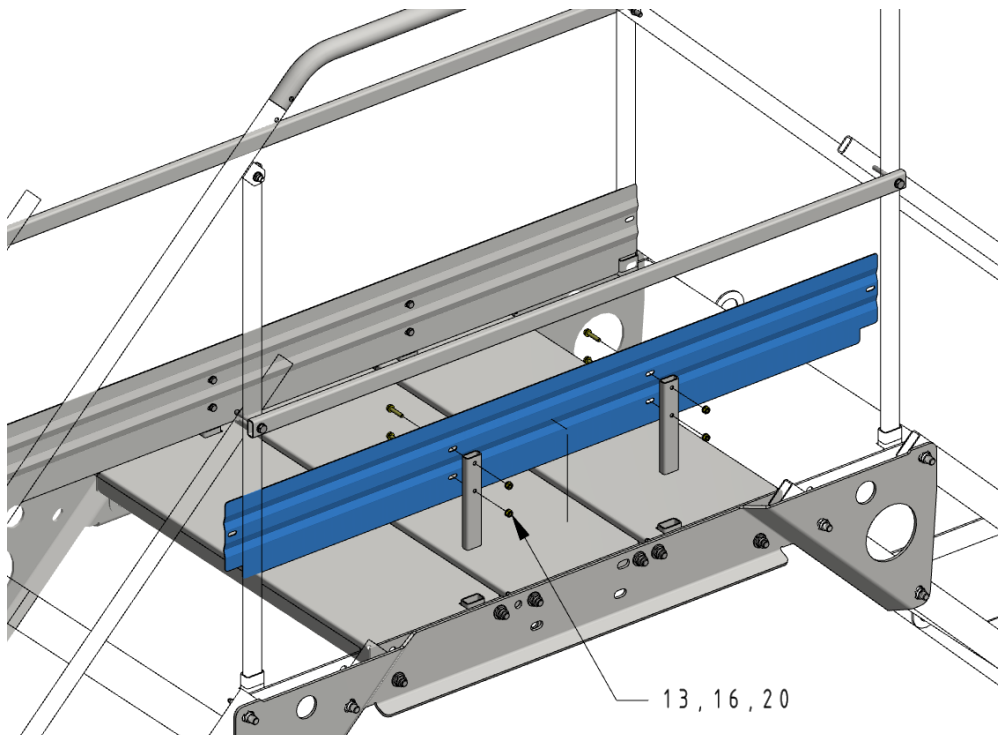



4.8. Truss assembly

4.8.1. When assembling TAS-WB1 truss for 15 step stairs, TAS-L4 middle connectors should be disassembled. The truss is fastened with bolts used to assemble steps.

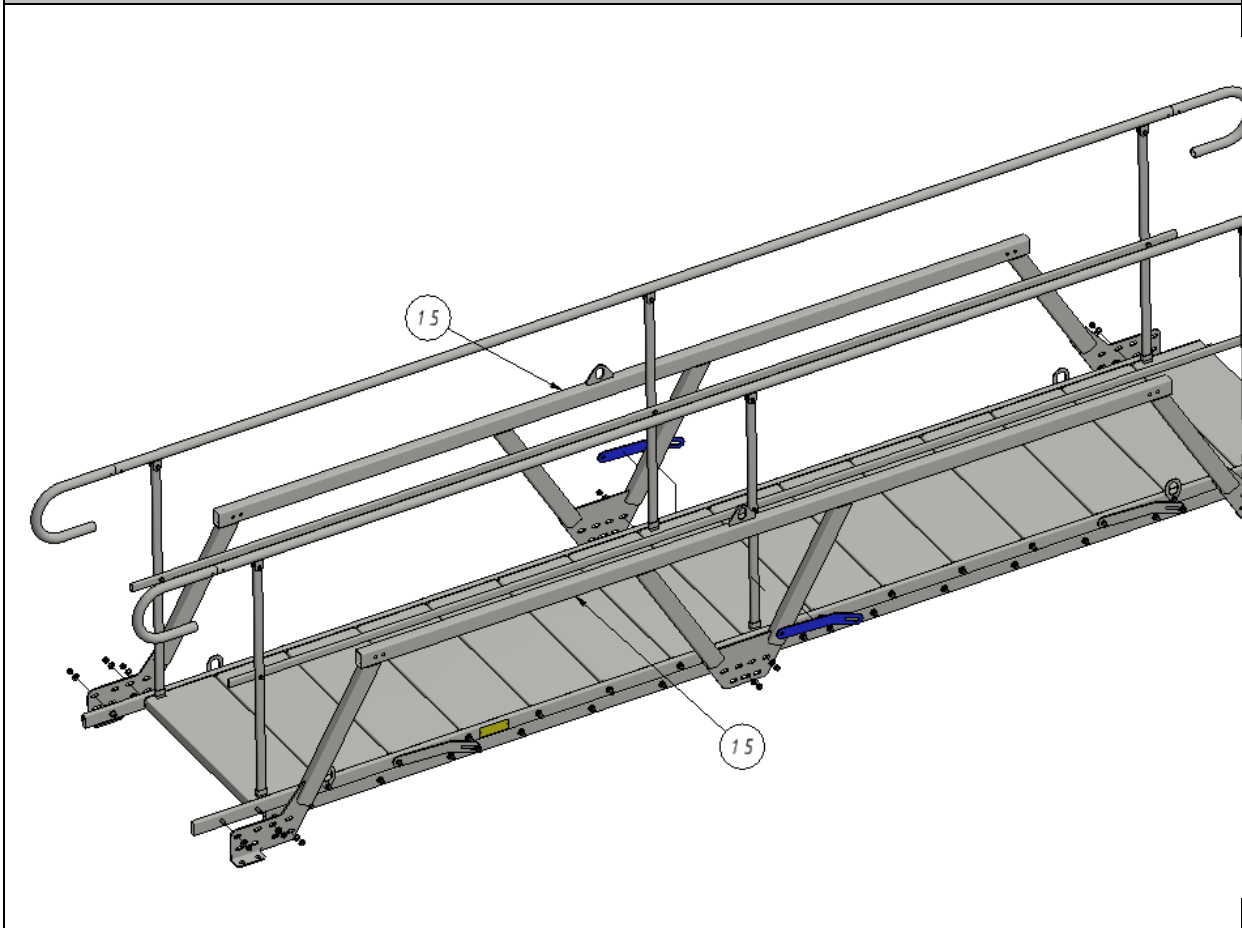

4.8.2. When assembling the truss for 18 step stairs, there is no need to disassemble TAS-L4 connectors. The TAS-WB1 truss is fastened with bolts used to assemble steps, TAS-WB2 component is fastened to TAS-WB1 with connectors included in the TAS-WB1 set.

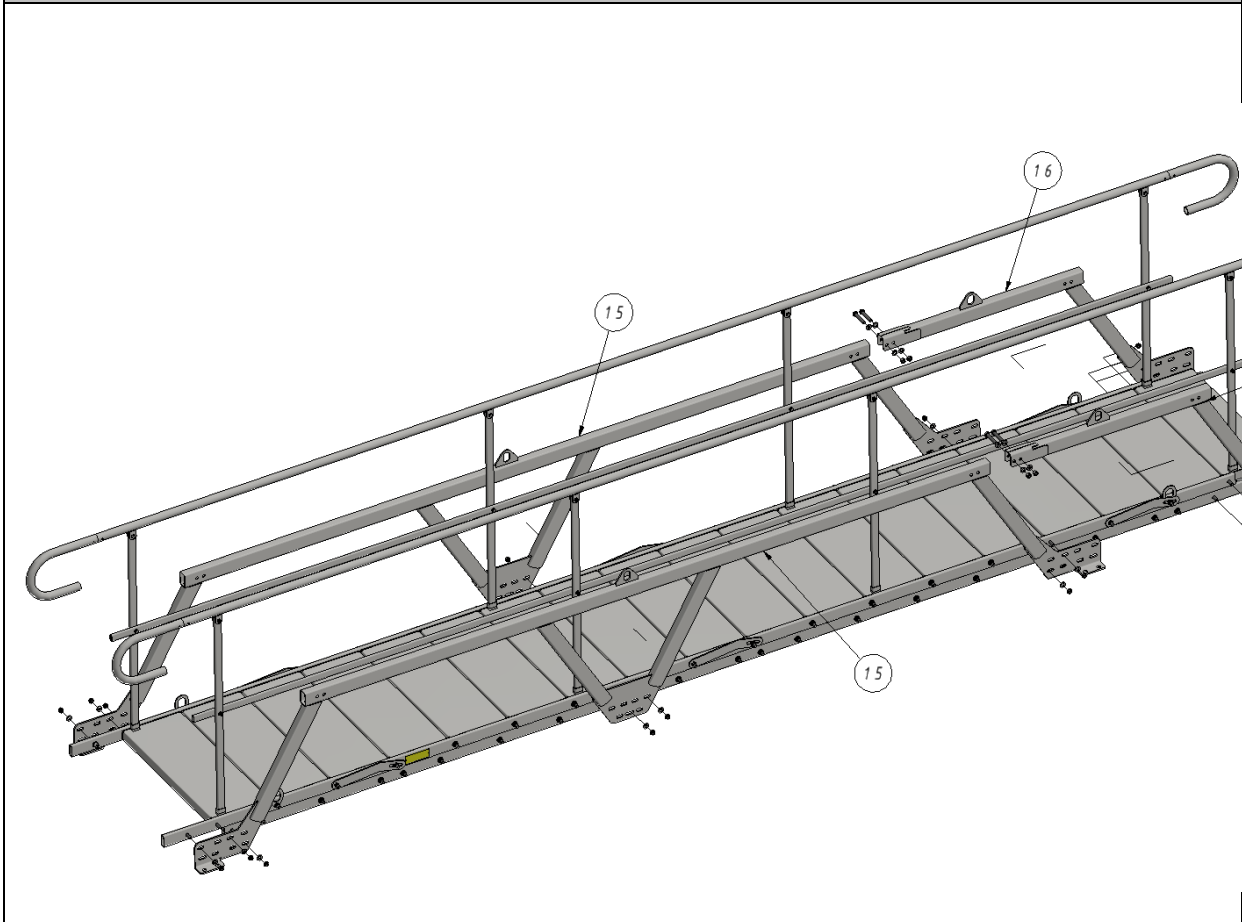

4.8.3. When assembling two flights of stairs with a truss, they should be fastened at the base with connectors used to assemble steps, and at the upper part with the TAS-WB3 bar using connectors included in the bar set. Before connecting the stairs, disassemble the railings. The connector sets used to connect the truss with the stairs should be tightened with the 60% of the torque indicated in tab.5.

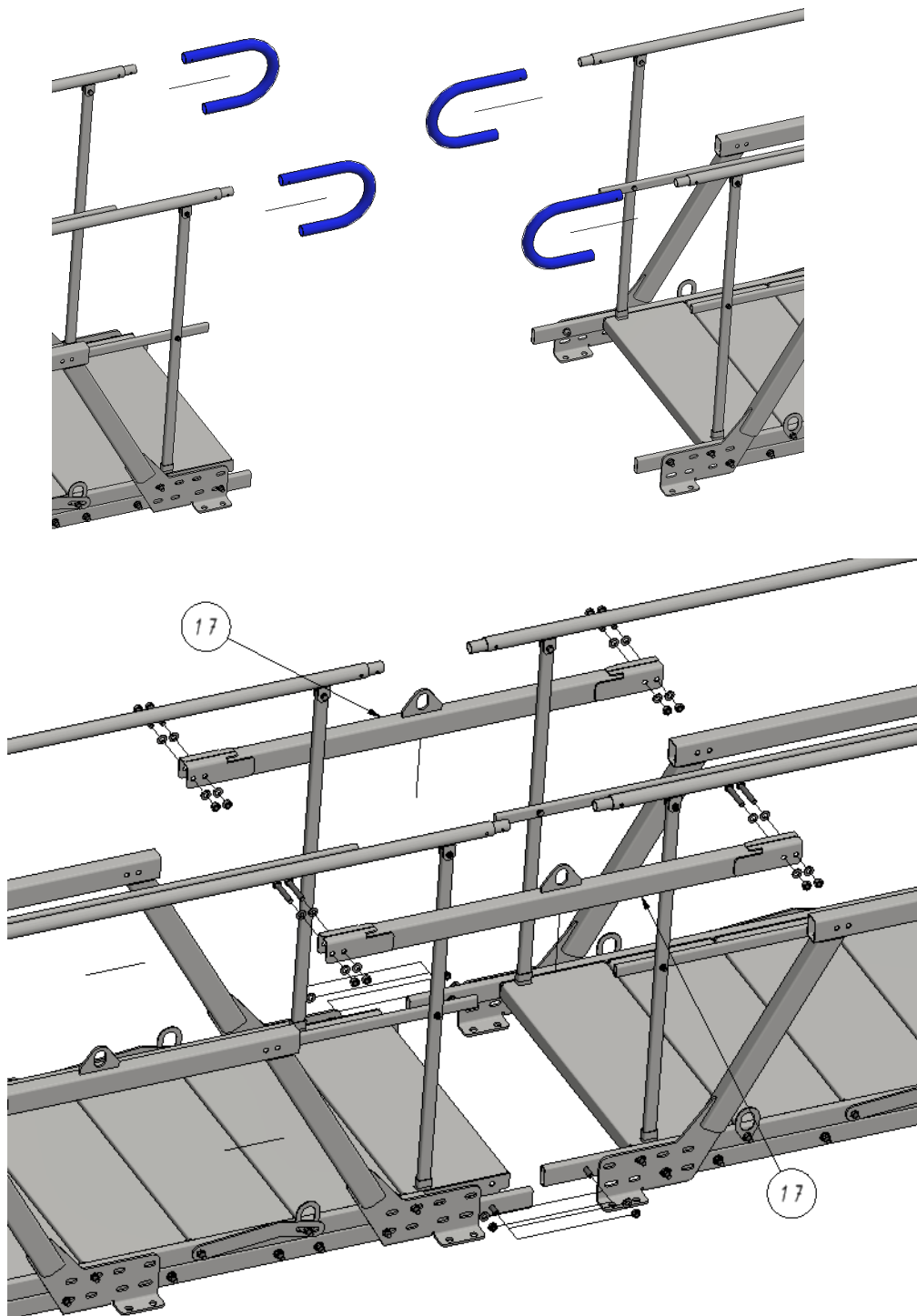

4.9. Assembly of pipe holders

4.9.1 To assemble the upper holder, disassemble the upper foot (see 4.5.2) and mount TAS-L15/ TAS-L14 holders with the same bolts. Prior to the assembly, the bolts on the lock must be loosened, the lock must be moved up, the holder is then placed and secured with the lock moved down again. Tighten the bolts.

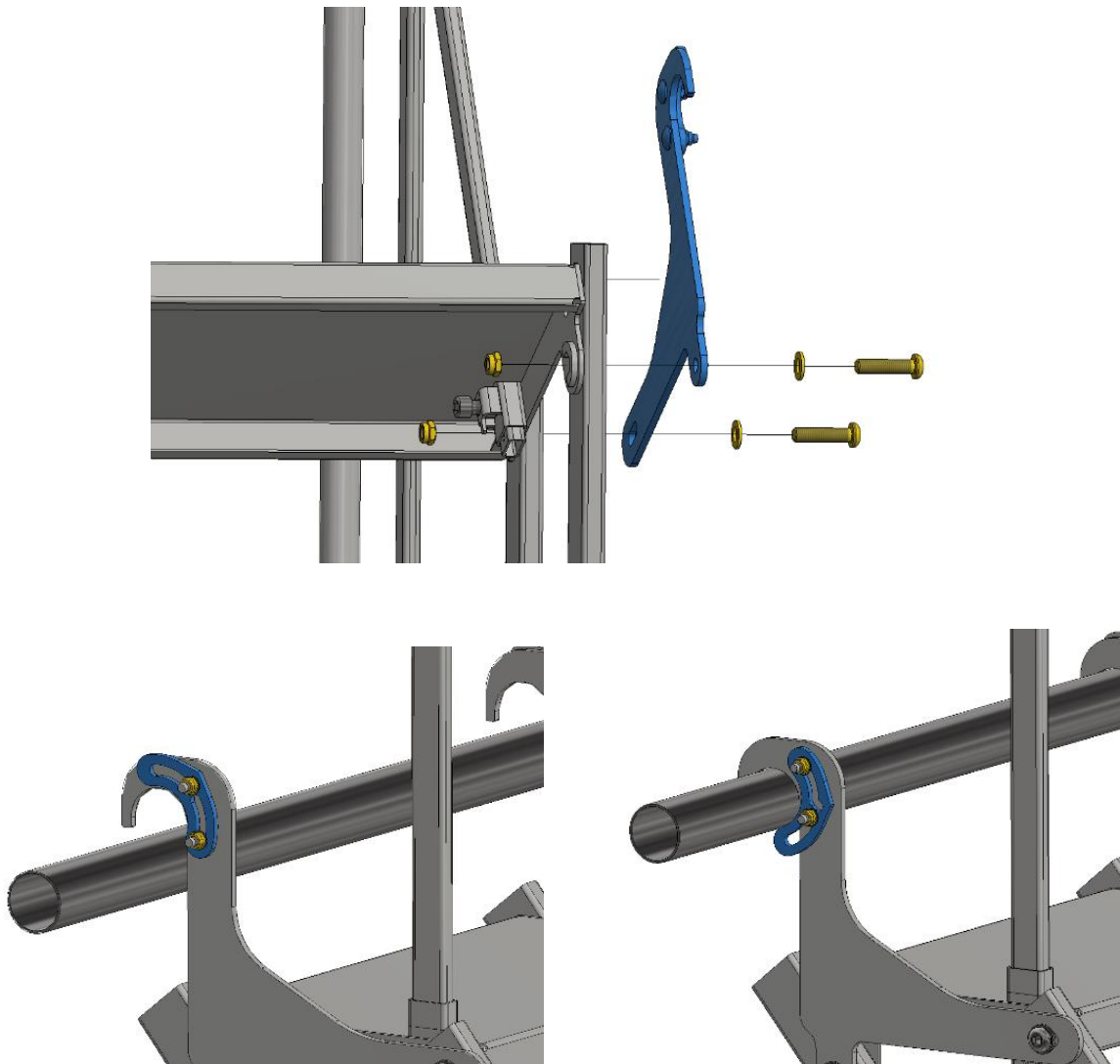

4.9.3 To assemble the lower holder, disassemble the lower foot (see 4.5.2) and assemble TAS-L16 / TAS-L17 holders using the same bolts. Prior to the assembly, loosen the screws on the foot that fasten the lock, move it up, place the holder and secure it with moving the lock down. Tighten the bolts.

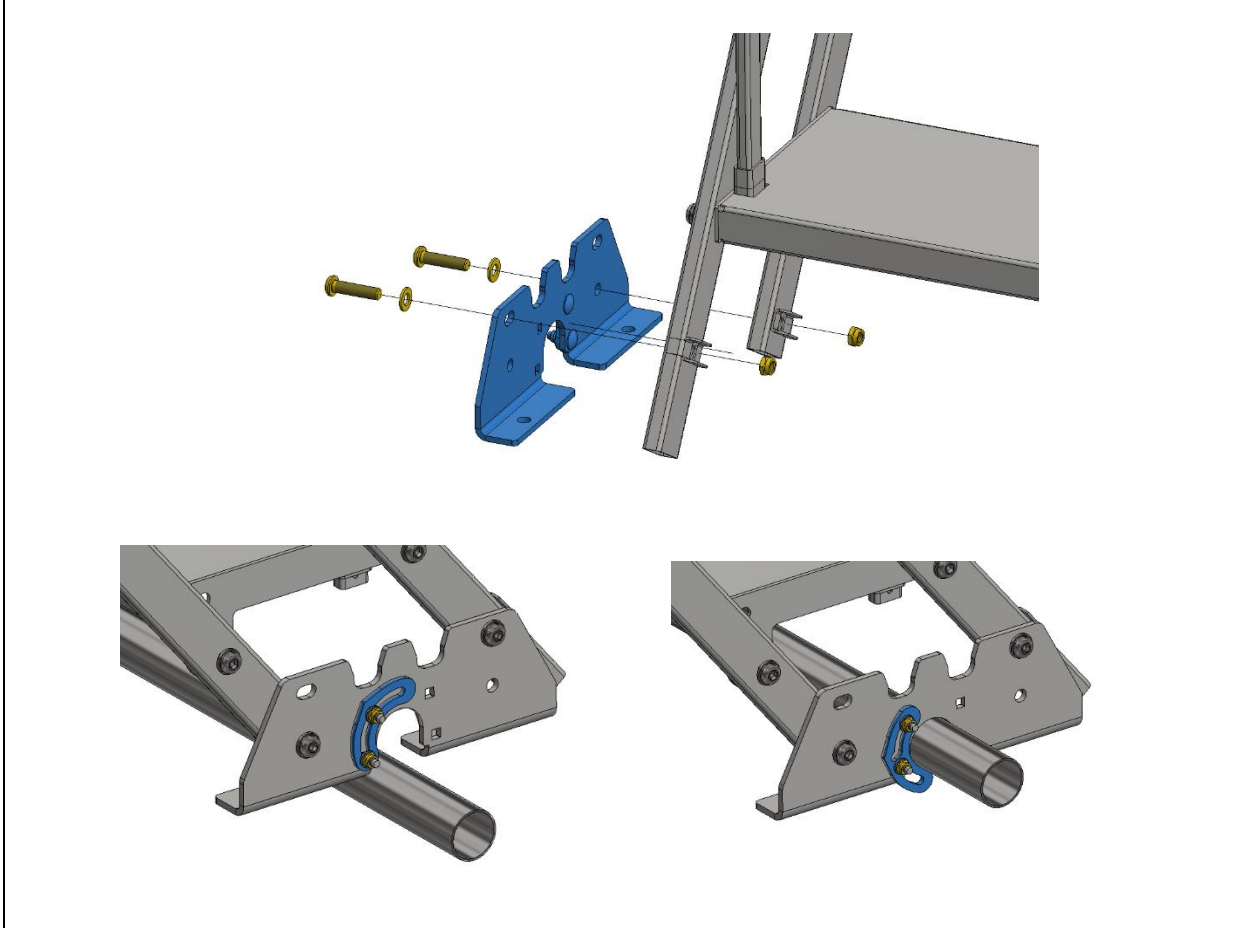

4.9.2 Assembly of the complementary railing - unbolt the nuts, slide in the railing, screw the nuts.



5. Assembly of stairs and gangways

The assembly should be conducted after earlier preparation of the ground, which means levelling and providing a stable support for the stairs during the entire exploitation process. Considering the temporary character of the construction, it is allowed to mount it on reinforced concrete slabs, concrete blocks or wooden blocks. When concrete or wooden blocks are used, it is required to place them on hard, gravelled, properly drained surface. It is required to provide proper draining system when assembling on ground. Additionally, the stairs must be anchored using the openings in lower foot if they are assembled on ground (minimum anchor length =40cm).

There is a possibility to connect flights of stairs to provide communication route to storeys of a building.

In such case, it is allowed to connect max. two flights of stairs with a total number of steps not exceeding 24 steps, e.g. 12+12=24, 18+6=24. It is required to support the flight in the middle of its length with two PR-1 supports.

The distance from the excavation edge and stairs angle are shown on fig. 3.

Stairs with 3, 6, 9, 12 steps can be used as a gangway over the excavation, with a minimum distance of $D = \min. 500\text{mm}$ from the both excavation edges on which the gangway has to be supported. Stairs with 15 or 18 steps that can be used as gangways after assembling the truss (TAS-WB1 and TAS-WB2 components). There is a possibility to connect 15- and 18 steps stairs equipped with trusses in 15+15, 15+18, 18+18 steps configurations (a number of components shown in tab 5.). In this case, a minimum distance of the gangway foot from the excavation edges must be $D = \min. 700\text{mm}$. Additionally, the gangway must be anchored to the ground.

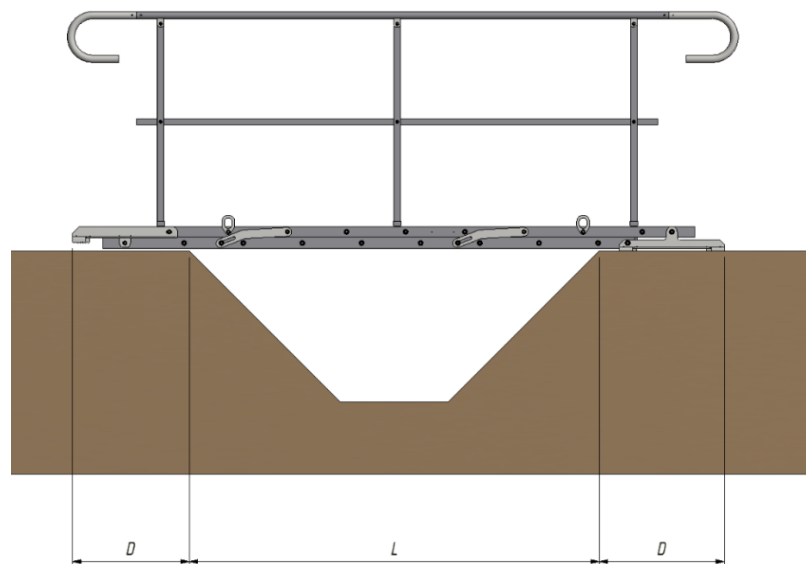

Fig. 2- Gangway over excavation

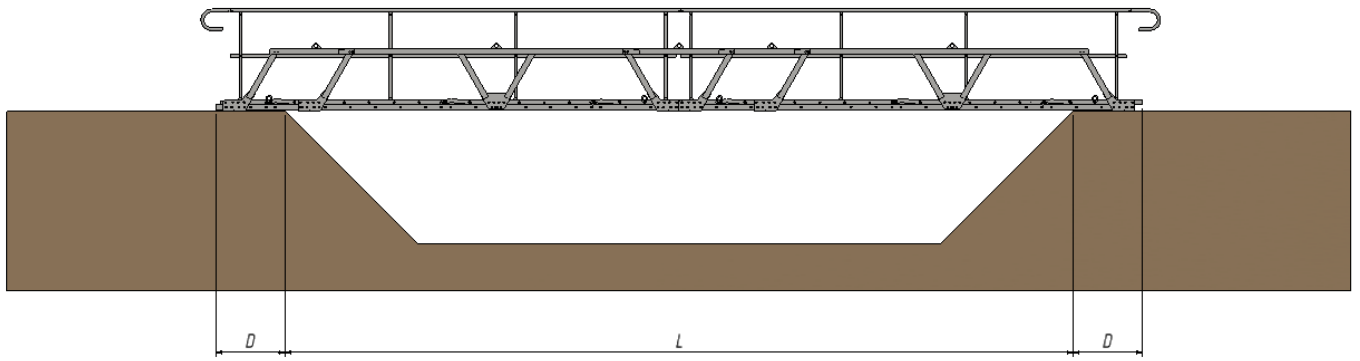

Fig.3- Gangway made of 2 flights reinforced by a truss.

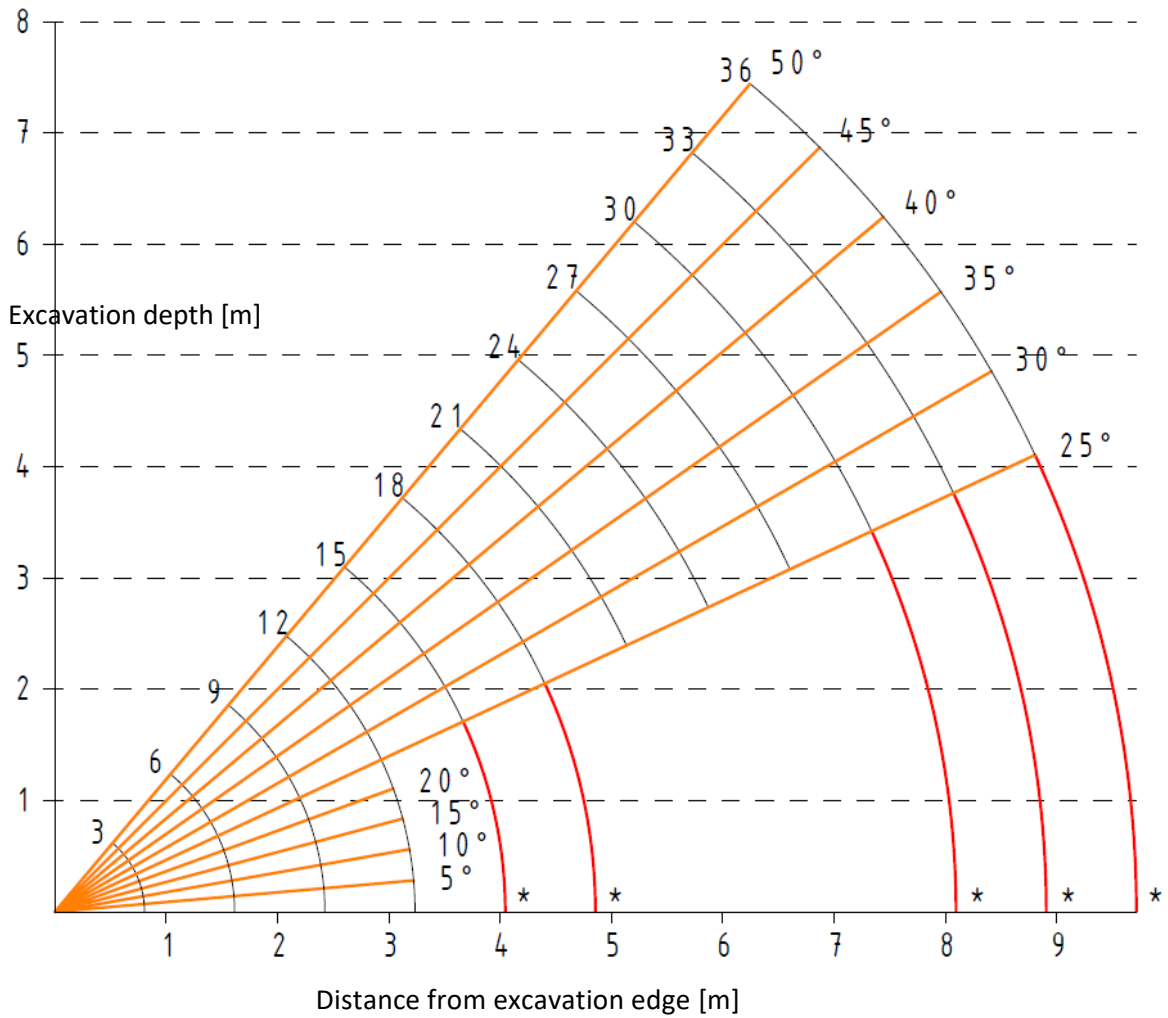

Fig. 4- Angle and distance from the edge.
* gangway reinforced by a truss.

The stairs should be assembled on excavation by at least two qualified specialists and a crane.

1. Prior to the assembly, one should determine the assembly zone in such a way that it will not interfere with construction works and cause any danger.
2. Determine the place of stairs assembly in such a way that it will not interfere with construction works and cause any danger
3. Determine and prepare the zone where the stairs are to be placed on.
4. Lift the stairs with a crane and put them on previously prepared ground.
5. Base the stairs on the excavation edge.
6. Immobilise the construction by anchoring and tightening the screws.

For 15- and 18-step stairs, we recommend previous determination of the stairs angle and tightening of the screw connections with tightening around 60% of the recommended torque for a particular connector diameter and class (see tab.5).

6. Operational conditions

The basis for the proper operation of the stairs is their appropriate setting. This primarily concerns the proper levelling of the ground on which the stairs will be placed. Too large deviation from horizontal causes all the steps to be set incorrectly which may cause difficulties in exploitation and the risk of accidents.

Therefore, the stairs should be periodically examined – if the ground has not moved, which would cause stairs deviation, as well as all thread connections.



To ensure proper operation when using the stairs, at the assembly of individual components the following steps should be performed:

- Fix the lower part of the stairs, preventing them from shifting and lifting.
- Fix the upper part of the stairs to make them lean against a stable edge in the form of a block of wood or concrete.
- Tighten the lock.



The range of activities related to the adjustment and setting also includes checking and possible tightening the bolted joints.

7. Disassembly

Before disassembly determine the safe area. Disassemble the gangway using the crane after making sure that it is not fixed to any of the excavation edges. Stairs disassembly should be performed in reverse sequence to the assembly. It should be performed by at least 2 qualified specialists.

8. Disposal

Packaging and worn-out tools should be stored, reused or disposed according to recommendation and regulations that are in force at your country / region.