

Attachment No. 1 to
Operation and Maintenance Documentation
TUP temporary unloading platforms
TUP-1.25, TUP-1.5, TUP-2.2

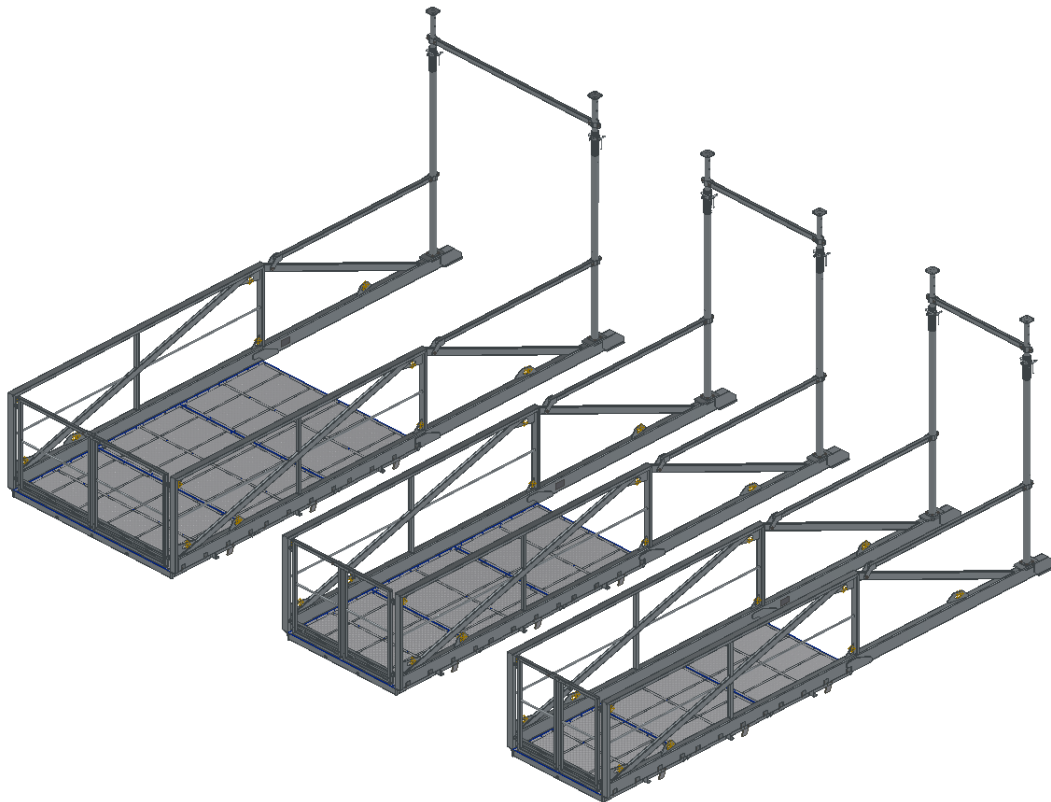

Piotr Abram
(Prepared by)



(Signature)

Robert Cieśla
(Checked by)



(Signature)

Miłosz Muzyka
(Approved by)



(Signature)

Issue 2.5, March 2023

Table of changes

NO.	FULL NAME	DEPT	DATE OF CHANGE	SCOPE OF CHANGE	NOTES
1	Piotr Abram	R&D	01.02.2021	Table 3	
2	Piotr Abram	R&D	20.04.2021	Point 3.9	
3	Piotr Abram	R&D	14.09.2021	Points: 3.3, 3.4, 3.6, 3.7	
4	Piotr Abram	R&D	25.11.2021	Point 3.1	
5	Piotr Abram	R&D	24.03.2022	Point 3.1	
6	Piotr Abram	R&D	07.03.2023	Point 3.3 gate protection	
7					
8					
9					
10					
11					
12					
13					
14					
15					

Table of content

1. Introduction	4
2. List of components	4
3. Assembly.....	12
3.1 General notes	12
3.2 Assembly of beams, platform.....	17
3.3 Gate assembly	18
3.4 Posts assembly	20
3.5 Assembly of the clamping beam	21
3.6 Bolt assembly	22
3.7 Ceiling assembly with the use of posts	23
3.8 Ceiling mounting with anchors.....	24
3.9 Assembly of panels on gates	25
3.10 Assembly of full panels	26
4. Notes.....	28

1. Introduction

Before starting work related to the assembly, transport and use of the unloading ramp, read the Operation and Maintenance Documentation and this assembly manual.

Assembly, transport, use not in accordance with the Operation and Maintenance Documents and the assembly manual is not allowed.

2. List of components

Working ramps consist of elements such as platforms, beams, posts. The components of the unloading ramp are presented in Table 1.

Table 1. List of components of unloading ramps.

No.	Name	Index	Weight [kg]	Quantity
1.	Right unloading ramp frame	TUP-RA1	180	1
2.	Left unloading ramp frame	TUP-RA2	180	1
3.	Unloading ramp platform 2.2	TUP-M1	103	3
4.	Unloading ramp platform 1.5	TUP-M2	78	3
5.	Unloading ramp 1.25	TUP-M3	69	3
6.	Right unloading ramp gate 2.2	TUP-FR1	17	1
7.	Left unloading ramp gate 2.2	TUP-FR2	17	1
8.	Right unloading ramp gate 1.5	TUP-FR3	14	1
9.	Left unloading ramp gate 1.5	TUP-FR4	14	1
10.	Right unloading ramp gate 1.25	TUP-FR5	13	1
11.	Left unloading ramp gate 1.25	TUP-FR6	13	1
12.	Support	D-400	27	2
13.	Clamping beam 2.2	TUP-B1	11	2
14.	Posts bolt 2.2	TUP-B2	10	1
15.	Posts bolt 1.5	TUP-B3	7	1
16.	Posts bolt 1.25	TUP-B4	6	1
17.	Beam connector	TUP-A5	0,65	2
18.	Bolt connector	TOP-A6	0,64	2
19.	Gate lock	TUP-Z1	1	1
20.	Empty platform panel 2.2	TUP-O4	0,8	2
21.	Empty platform panel 1,5	TUP-O5	0,5	2
22.	Empty platform panel 1,25	TUP-O6	0,4	2
23.	Gate panel P1a	TUP-P1a	2,9	2
24.	Gate panel P1b	TUP-P1b	1,9	2
25.	Gate panel P1c	TUP-P1c	1,5	2
26.	Side panel P2	TUP-P2	4,6	4

Table 2. List of fasteners.

No.	ID	Weight [kg]	Quantity
B.	Bolt ISO 4017 M10x70	0,054	3
C.	Bolt ISO 4017 M10x80	0,060	2
D.	Bolt ISO 4017 M12x110	0,114	6
F.	Bolt ISO 4017 M16x40	0,101	24
G.	Bolt ISO 4017 M16x90	0,180	2
H.	Self-locking nut ISO 10511 M10	0,009	9
I.	Self-locking nut ISO 10511 M12	0,013	14
J.	Self-locking nut ISO 10511 M16	0,029	26
K.	Washer ISO 7089 10	0,004	18
L.	Washer ISO 7089 12	0,006	16
M.	Washer ISO 7089 16	0,011	52
N.	Washer ISO 7093 12	0,022	12
O.	Self-tapping screw DIN 7504 4,8x16	0,004	8
P.	T-bolt	0,055	4

Fasteners should be tightened with the appropriate torque for the given size and class of the fastener.

Table 3. Table of bolt tightening torques.

Fastener size	Class 8.8
M10	46 Nm
M12	79 Nm
M16	198 Nm

Table 3. Graphical list of components.

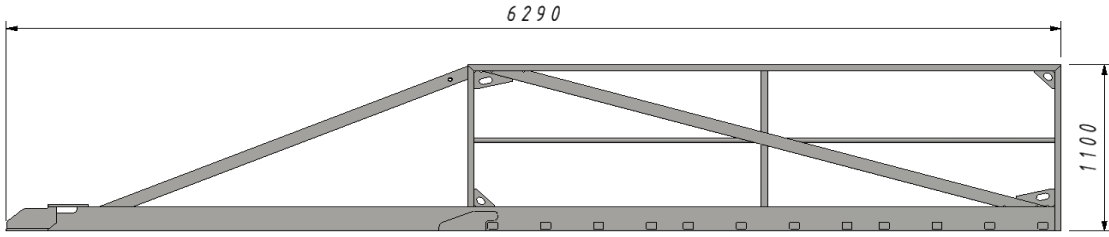
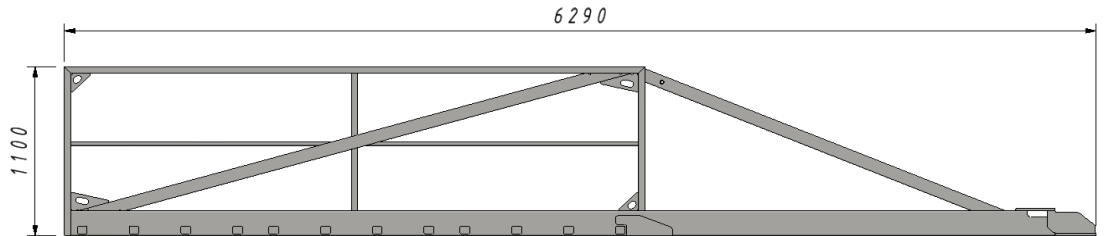
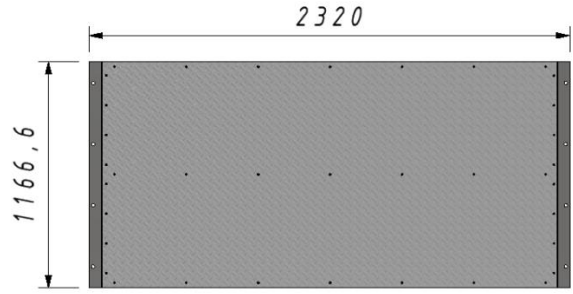
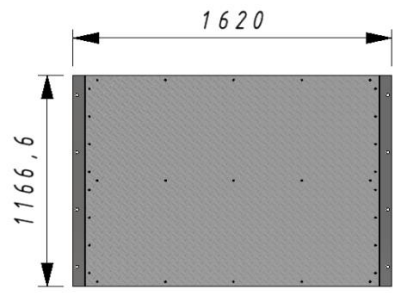
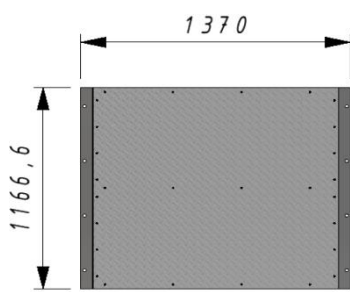
<p>TB-RA1</p>  <p>Weight: 180 kg</p>
<p>TB-RA2</p>  <p>Weight: 180 kg</p>
<p>TB-M1</p>  <p>Weight: 103 kg</p>
<p>TB-M2</p>  <p>Weight: 78 kg</p>
<p>TB-M3</p>  <p>Weight: 69 kg</p>

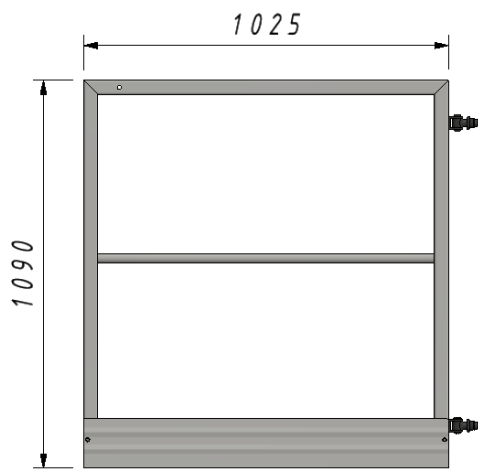
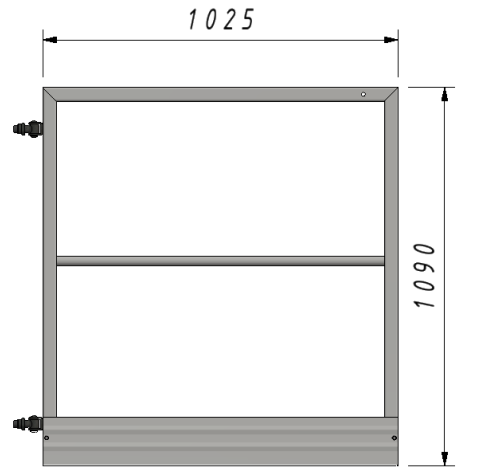
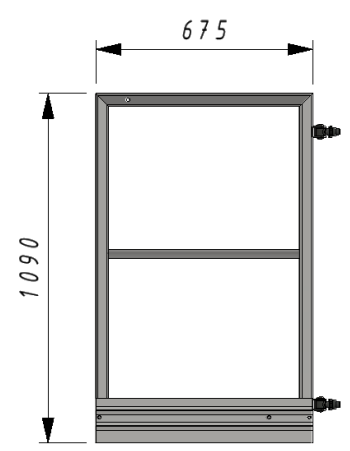
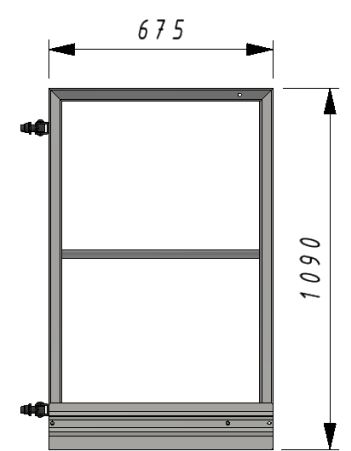
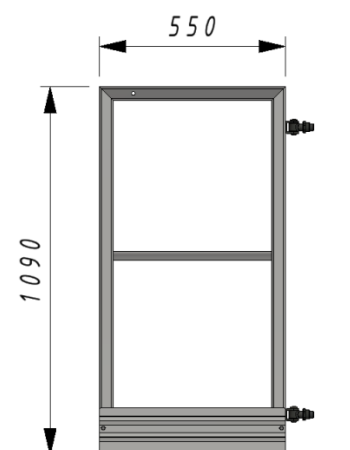
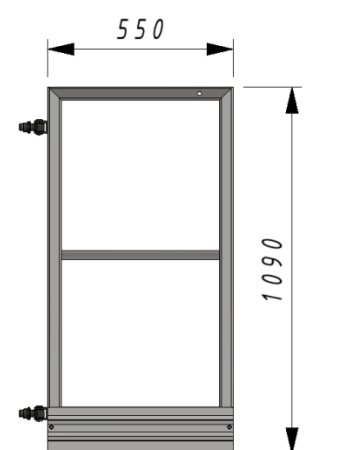
<p>TB-FR1</p>  <p>Weight: 17 kg</p>	<p>TB-FR2</p>  <p>Weight: 17 kg</p>
<p>TB-FR3</p>  <p>Weight: 14 kg</p>	<p>TB-FR4</p>  <p>Weight: 14 kg</p>
<p>TB-FR5</p>  <p>Weight: 13 kg</p>	<p>TB-FR6</p>  <p>Weight: 13 kg</p>

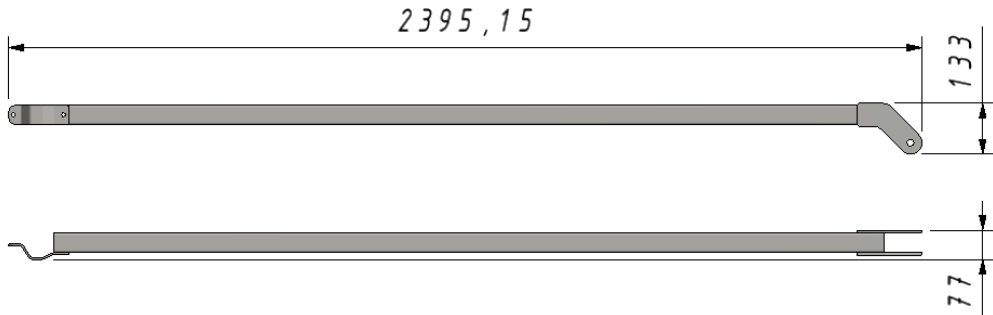
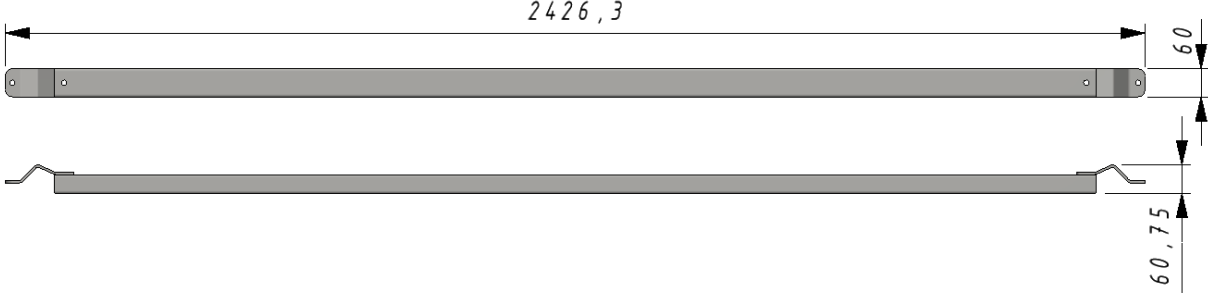
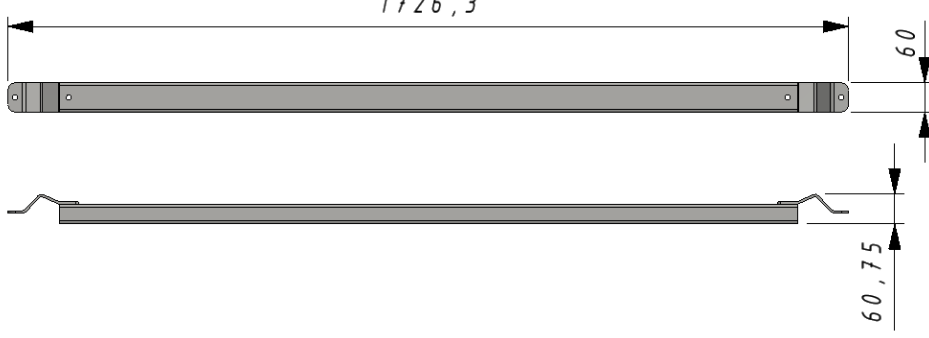
<p>Peri PEP Ergo D-400</p>  <p>Weight: 27 kg</p>
<p>TB-B1</p>  <p>Weight: 11 kg</p>
<p>TB-B2</p>  <p>Weight: 10 kg</p>
<p>TB-B3</p>  <p>Weight: 7 kg</p>

<p>TB-B4</p> <p>Weight: 6 kg</p>	
<p>TB-A5</p> <p>Weight: 0.65 kg</p>	<p>TB-A6</p> <p>Weight: 0.64 kg</p>
<p>TB-Z1</p> <p>Weight: 1 kg</p>	
<p>TUP-O4</p> <p>Weight: 0.799 kg</p>	

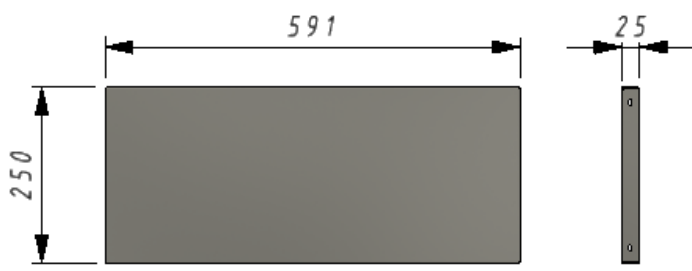
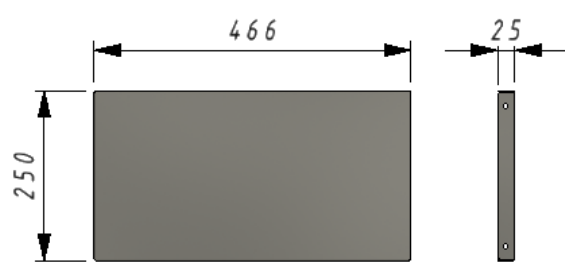
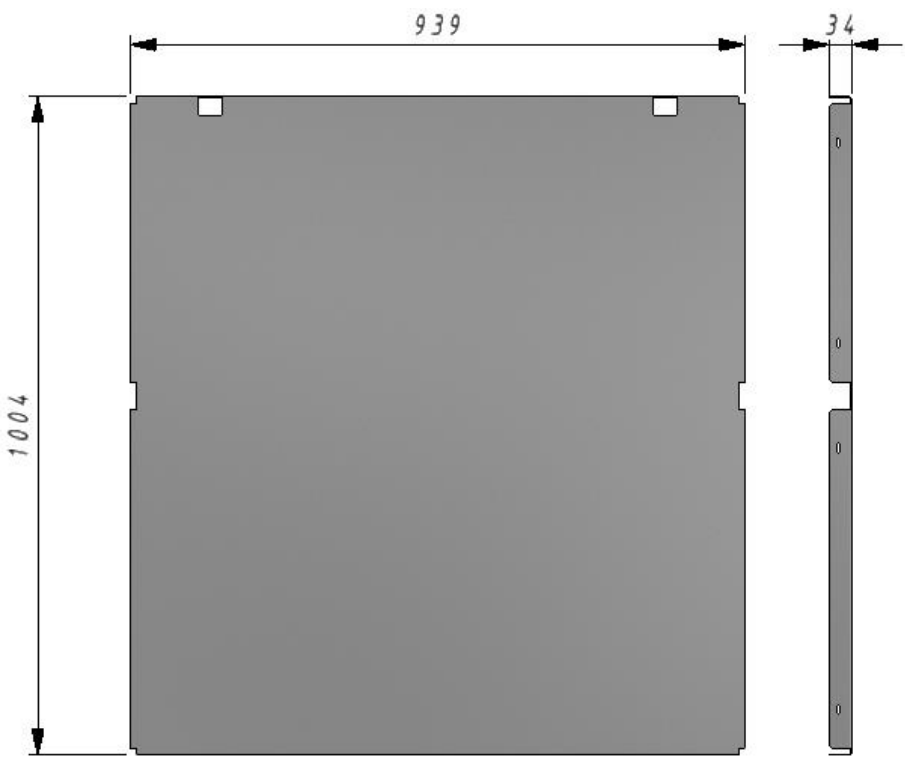
<p>TUP-O5</p>  <p>Weight: 0.518 kg</p>
<p>TUP-O6</p>  <p>Weight: 0.418 kg</p>
<p>TUP-P1a</p>  <p>Weight: 2.911 kg</p>

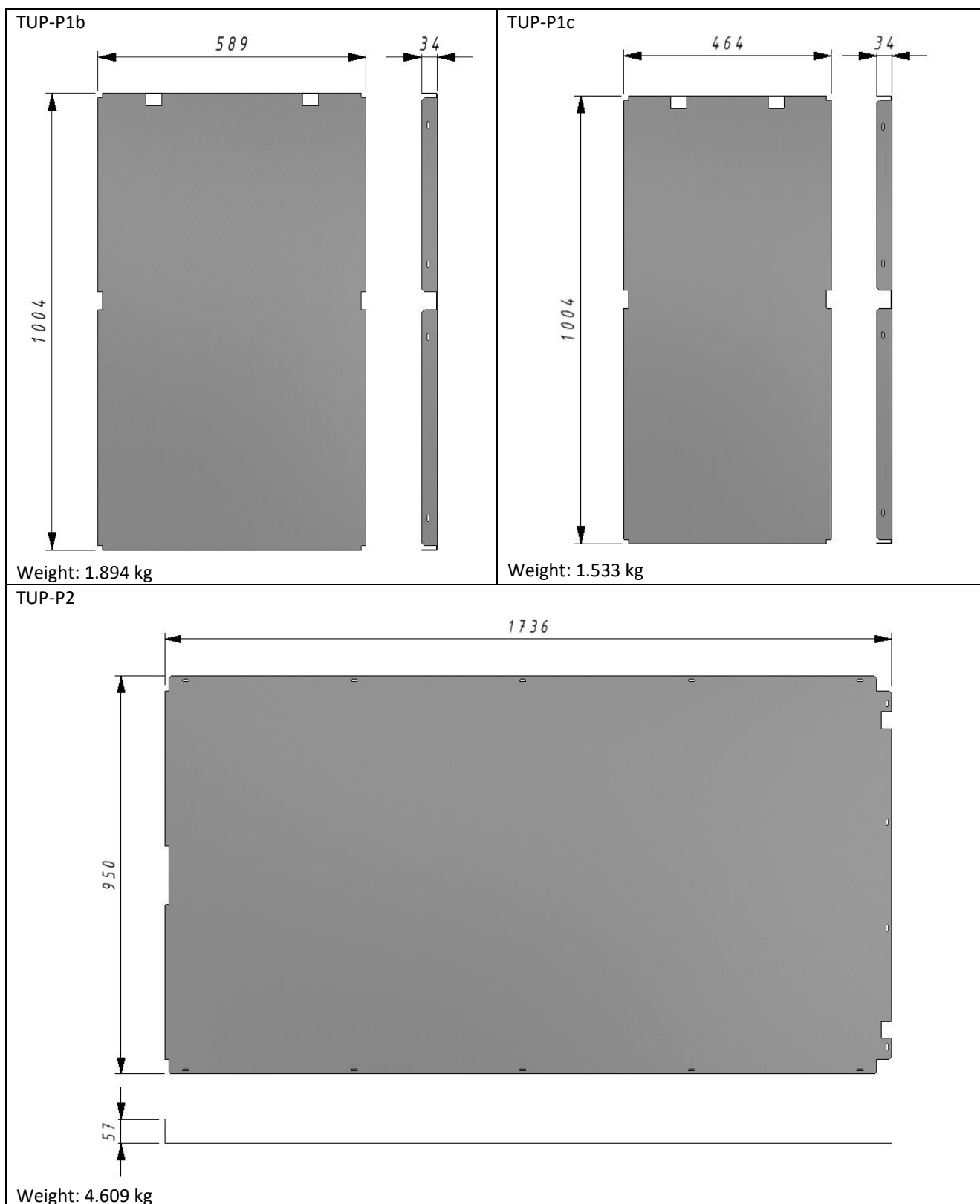

3. Assembly

3.1 General notes

The ramp should be assembled in accordance with the attached assembly manual and current health and safety guidelines.

The structure of the unloading ramp allows for two assembly methods. Assembly by strutting between the floors of the building and assembly by anchoring to the ceiling.

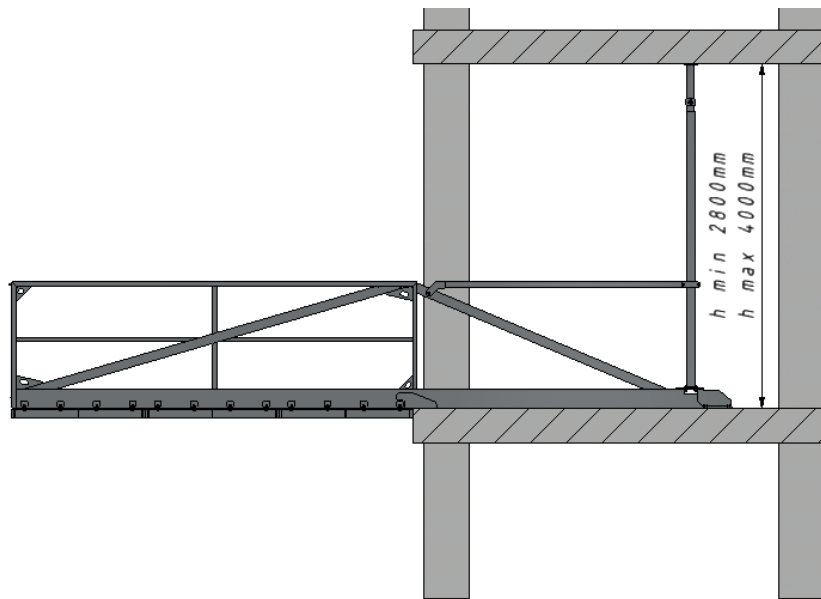

Fig. 1. Assembly between floors.

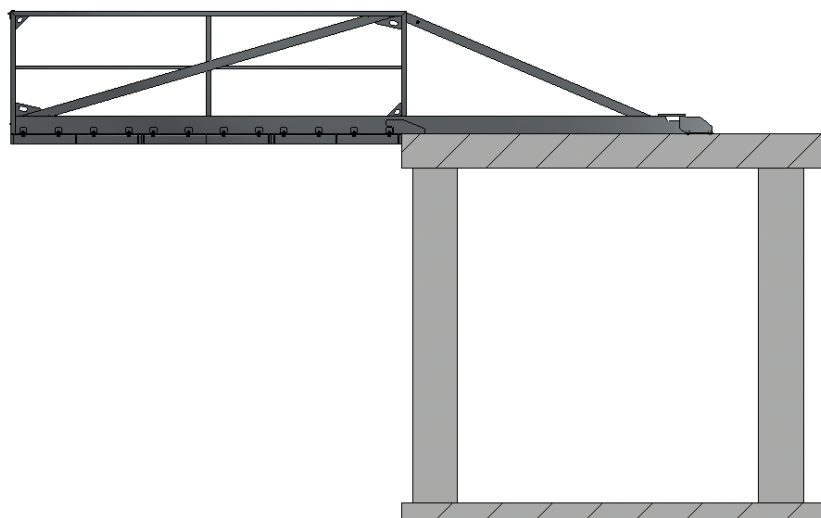

Fig. 2. Assembly by anchoring to the ceiling.

Before starting the assembly, it is necessary to:

- Visually check the condition of the ramp components in order to detect any damage.
- Make sure that the ground is clean and levelled to ensure proper adhesion.
- Make sure that the structure element to which the ramp will be attached will withstand the load according to Figures 3 and 4.
- Select the appropriate anchors for the load.

In the case of assembly between floors, due to the use of the recommended Peri PEP Ergo D-400 slab prop, the minimum height between the floors should not be less than 2800 mm, and the maximum height should not exceed 4000 mm. Alternatively, Peri PEP Ergo E-300, E350+, D-350+ slab props can be used, for which height h_{min} and h_{max} are different.

It is allowed to use other slab props than those recommended. The supports should be able to carry the required loads and have the appropriate spacing of the holes in the foot and the appropriate pipe diameters that will allow for correct assembly. The drawing below shows the required dimensions that the prop should meet. Using props other than the recommended heights h_{min} and h_{max} will change.

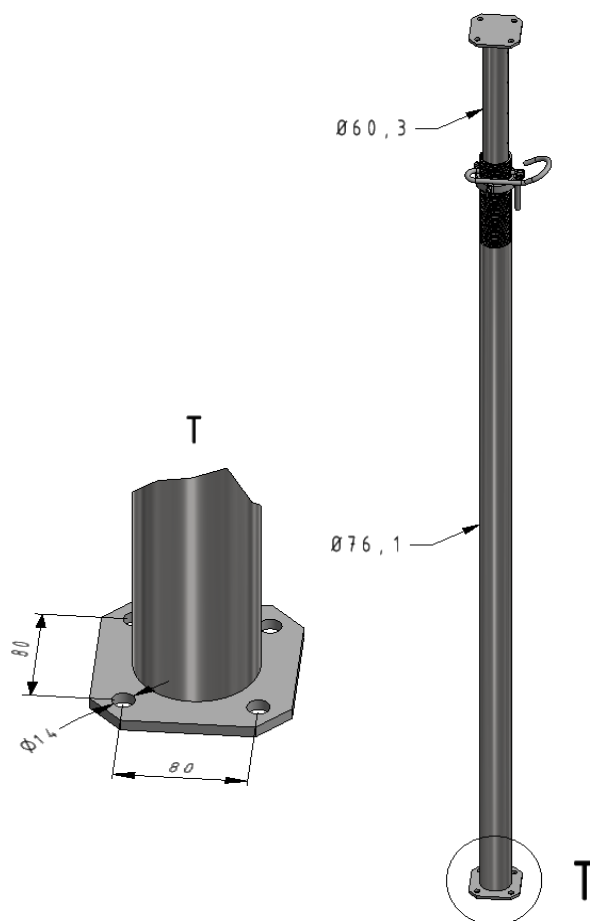

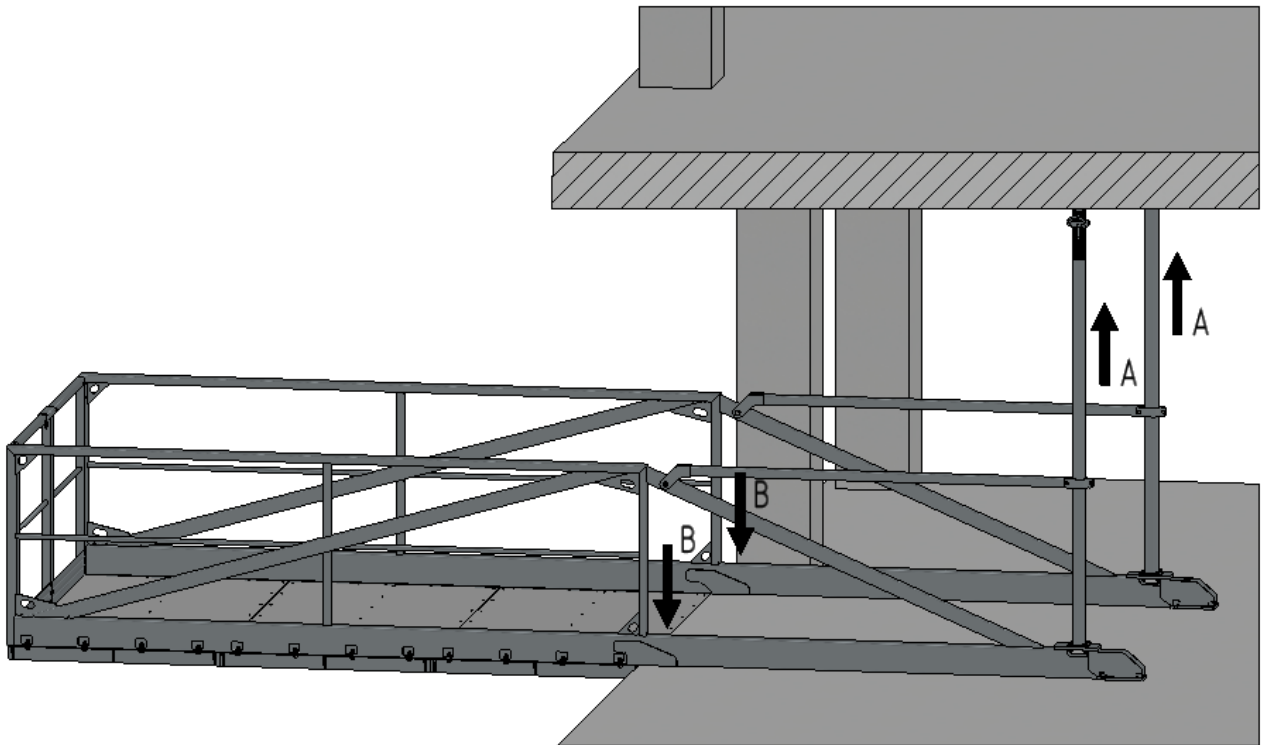
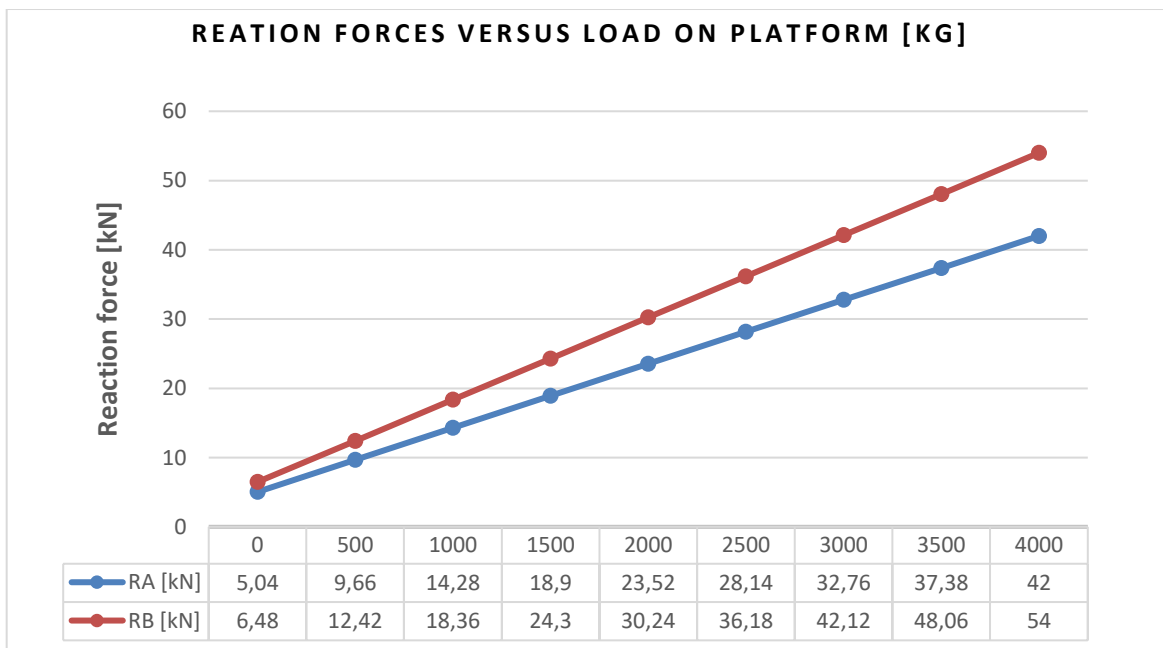

Fig 3. Reactions during assembly between floors.

Reactions in points A – max 42 [kN]

Reactions in points B – max 54 [kN]

The diagram below shows the relation between reaction forces and load on the platform.



The bearing capacity of the slab prop Q changes depending on its extension L_p . installation site. Each time when starting assembly of the unloading platform with the use of slab props, maximum planned load at which the platform will operate should be taken into account in order to select a prop that will ensure the appropriate load capacity with the necessary spreading adjusted to the height of the ceiling at the installation site.

This relationship is presented below on the example of the recommended PEP Ergo D-400 slab prop. This support allows the platform to be loaded with a maximum weight of 3800 [kg] when extended in the range of 2.6 - 3.0 m (which gives a ceiling height of 2.78 to 3.18 m).

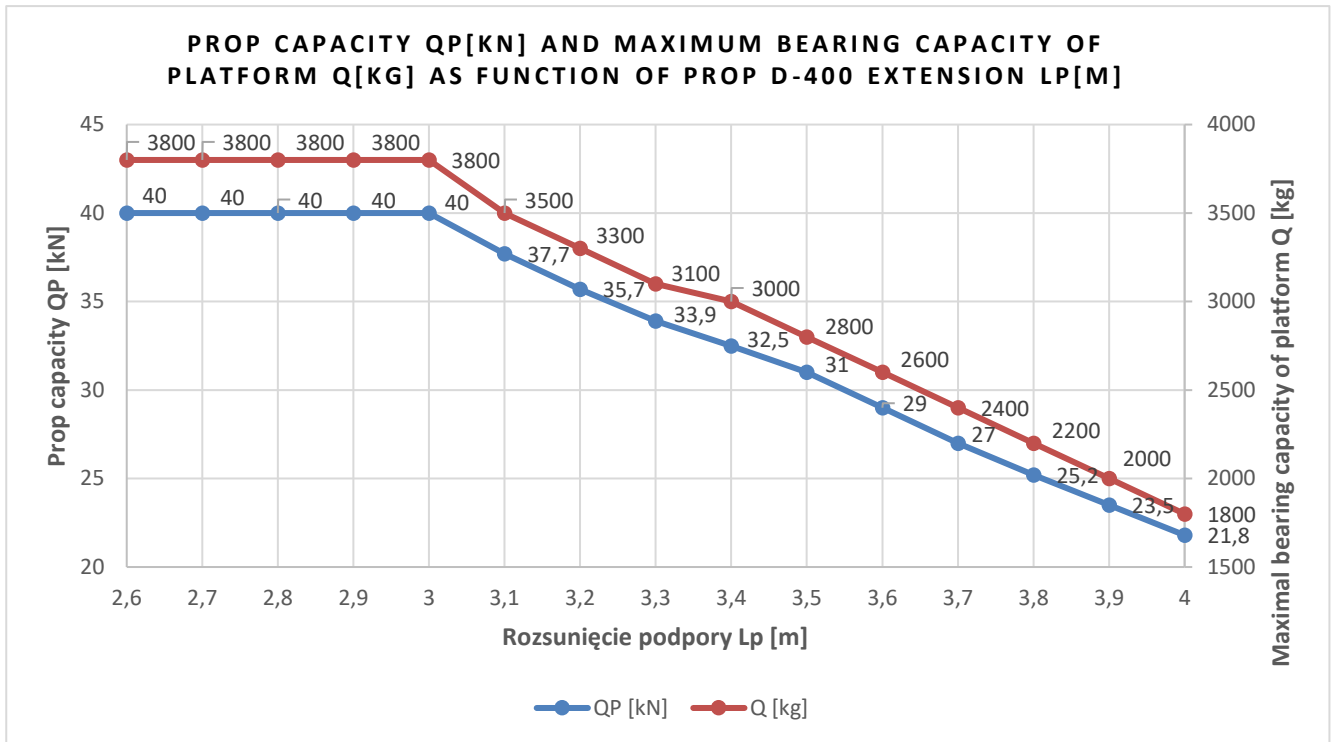

In the case of installation by anchoring to the ceiling, anchoring elements with a load capacity appropriate to the expected maximum load of the platform should be used, i.e. those that will transfer the above reaction forces RA, taking into account the anchoring conditions prevailing at the installation site. The construction services are responsible for the selection of anchoring materials and verification of the floor load capacity.

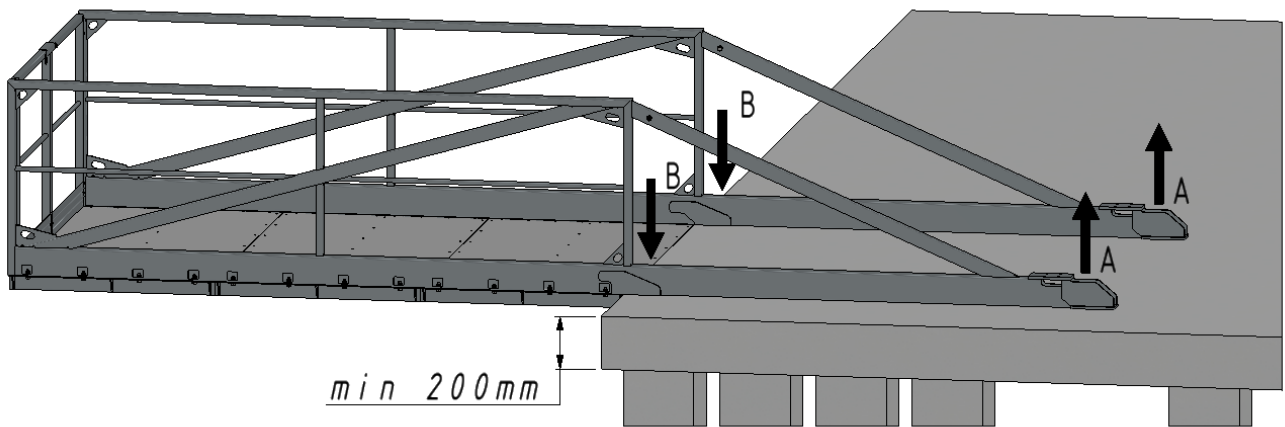
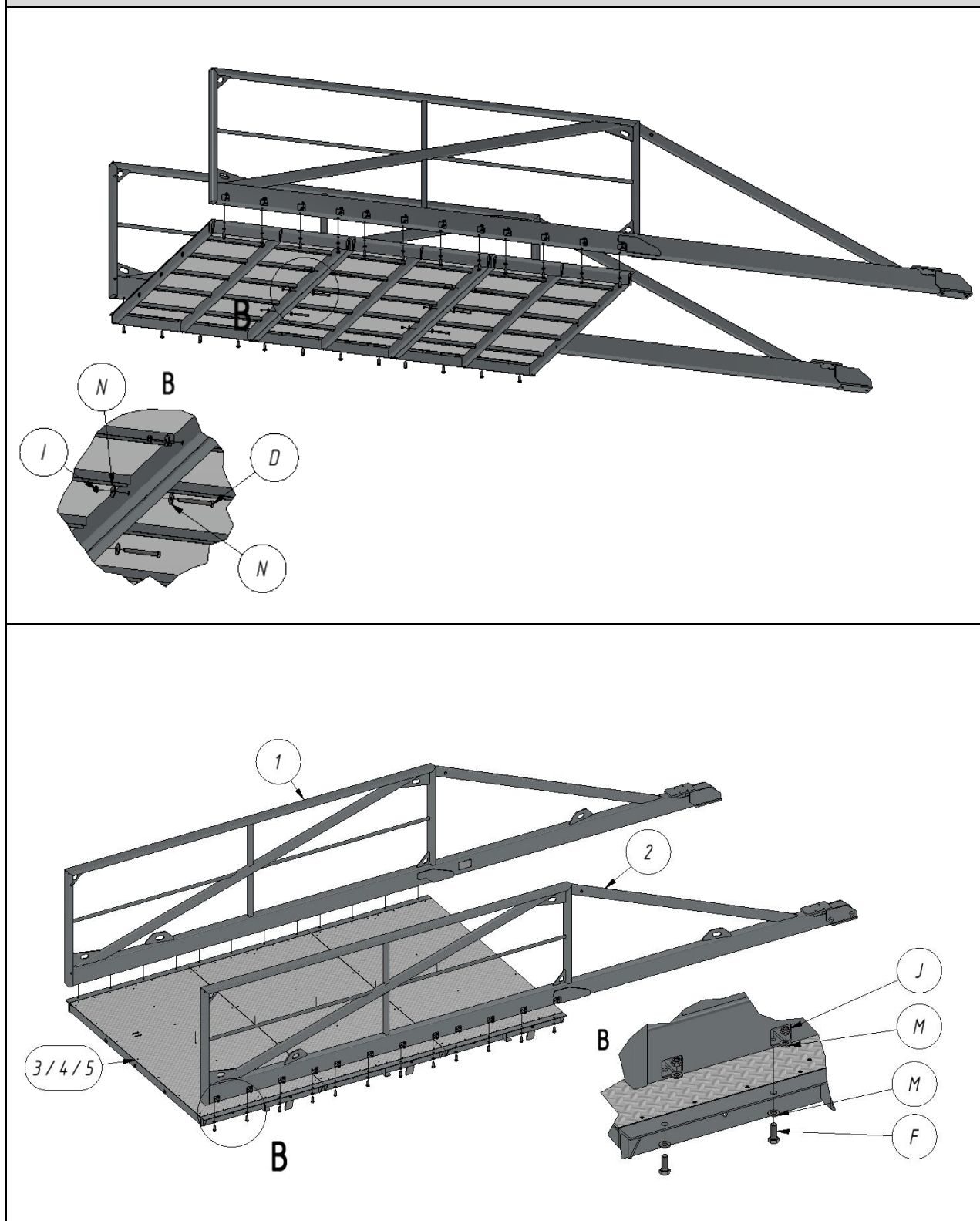

Fig. 4 Reactions during assembly by anchoring.

With both methods of anchoring, the ceiling thickness should **not be less than 200mm** and the concrete from which it is made should achieve the designed load capacity.

3.2 Assembly of beams, platform



3.3 Gate assembly

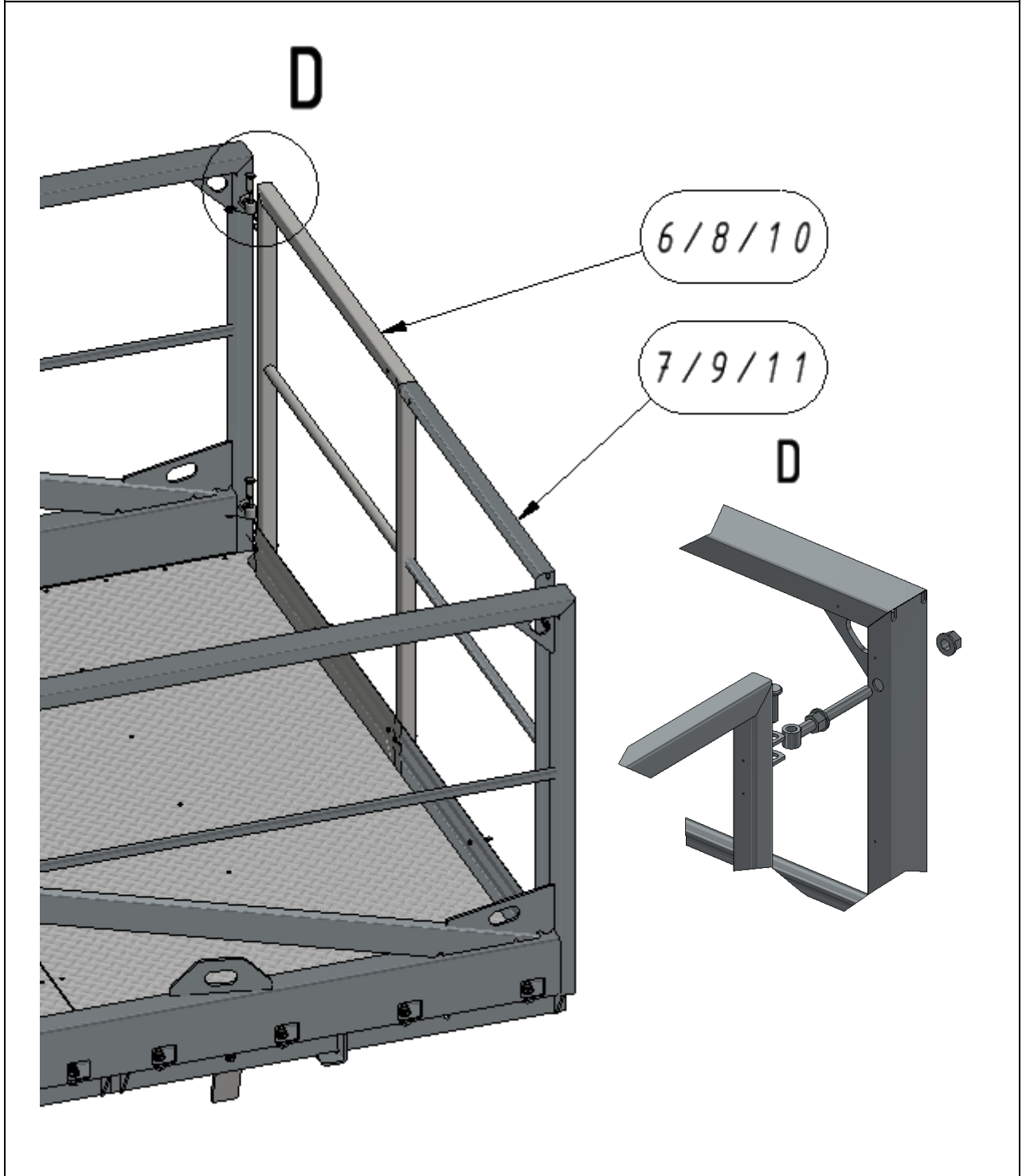

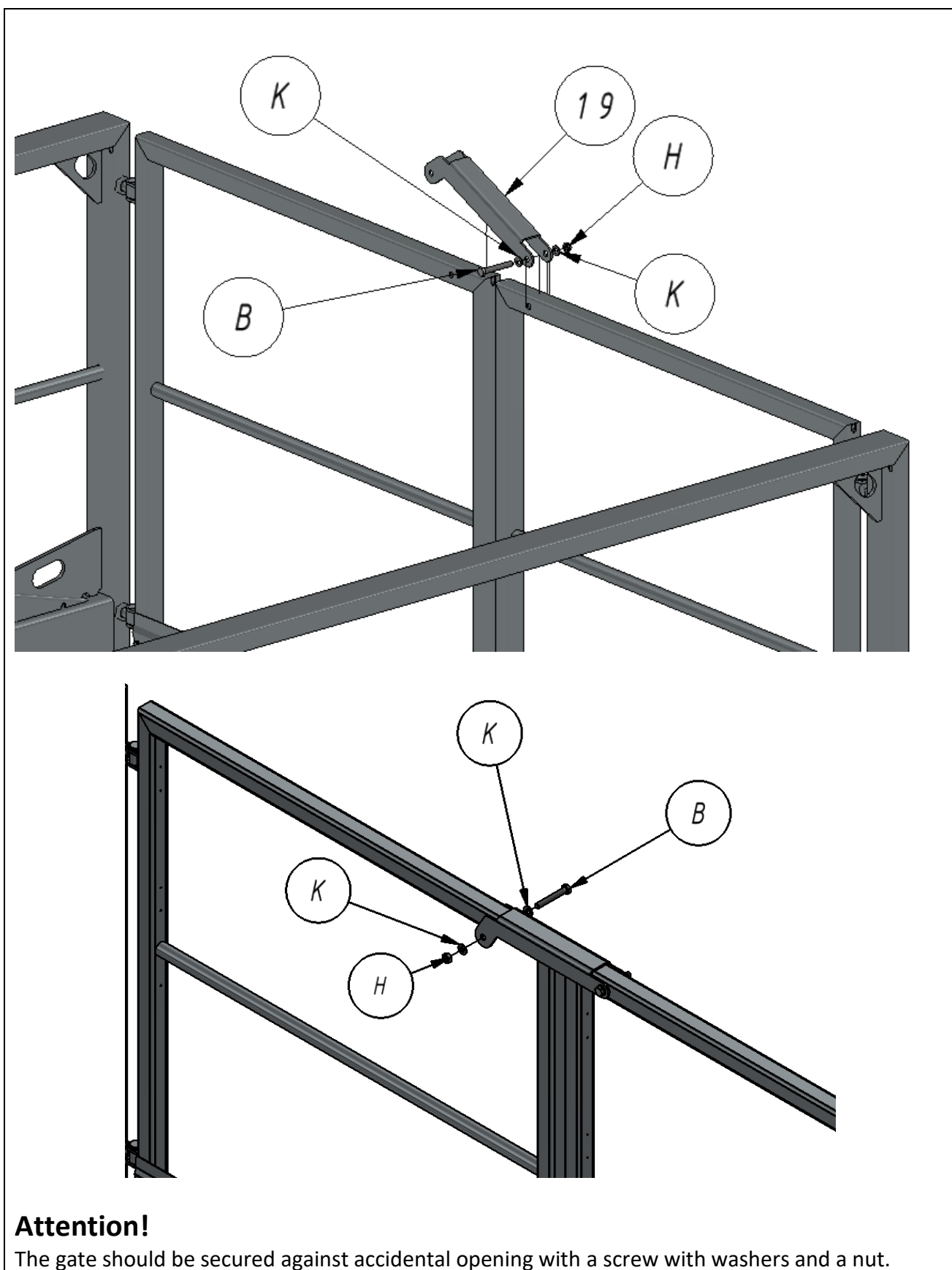

3.4 Props assembly

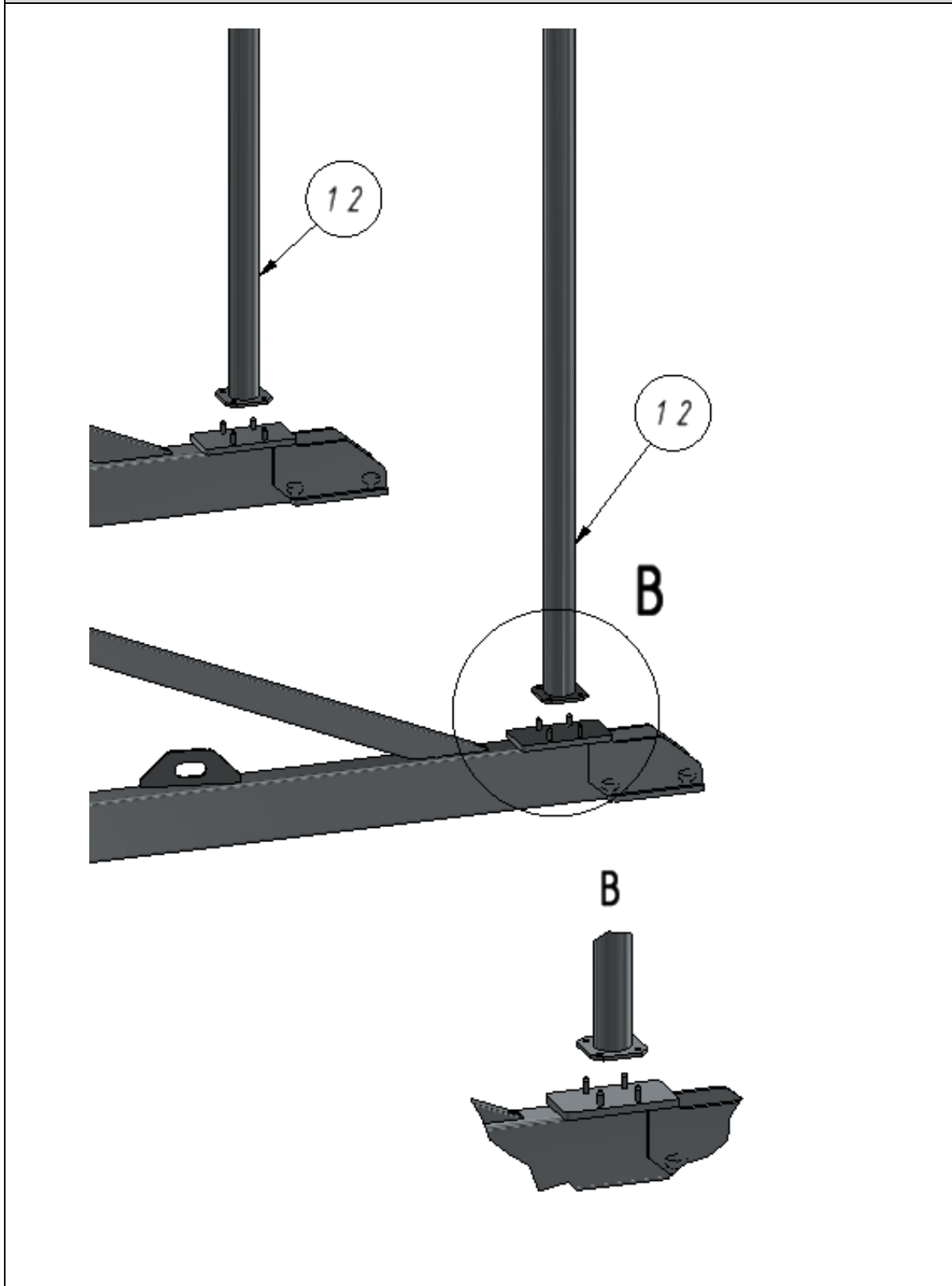

3.5 Assembly of the clamping beam

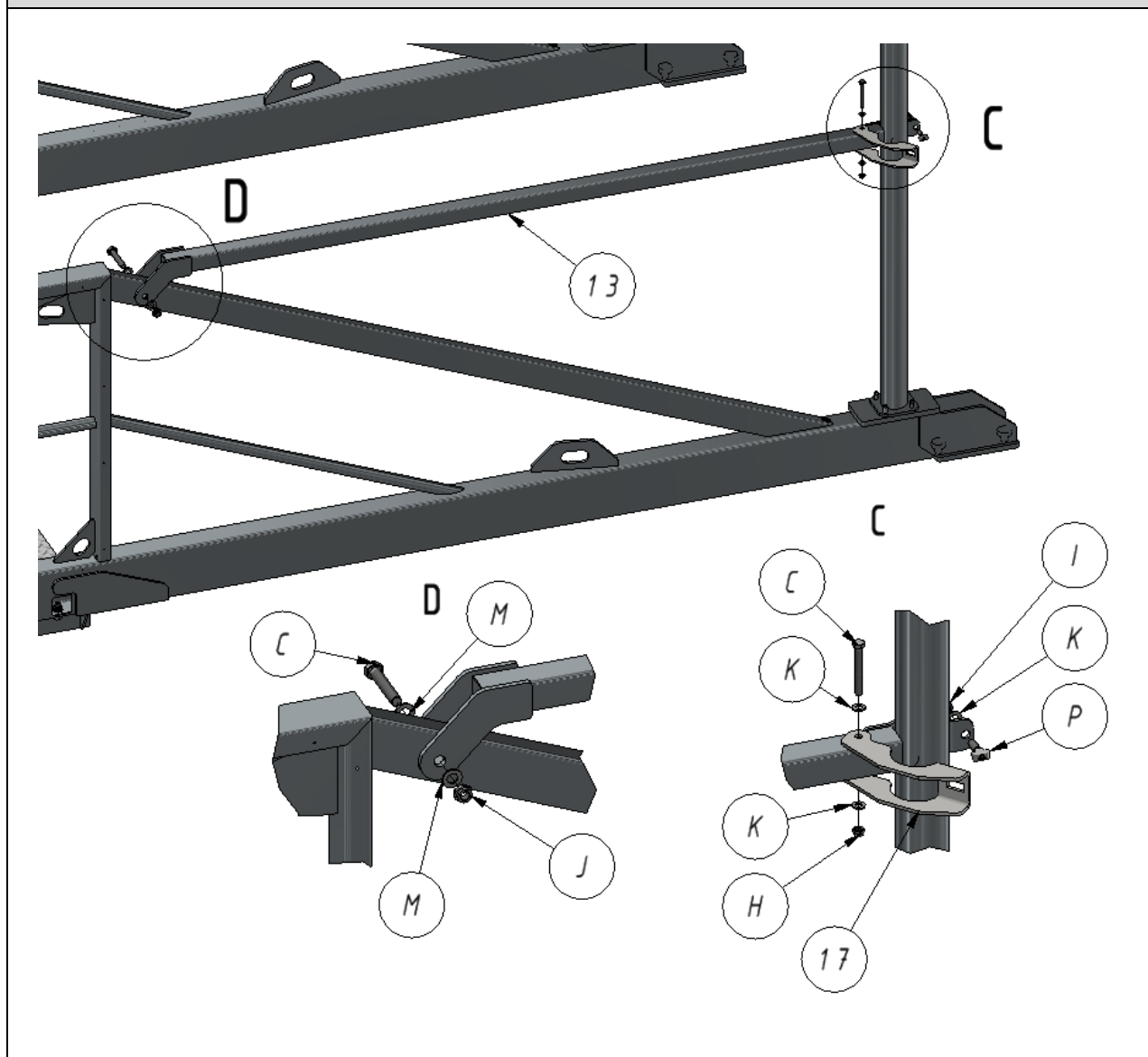

3.6 Bolt assembly

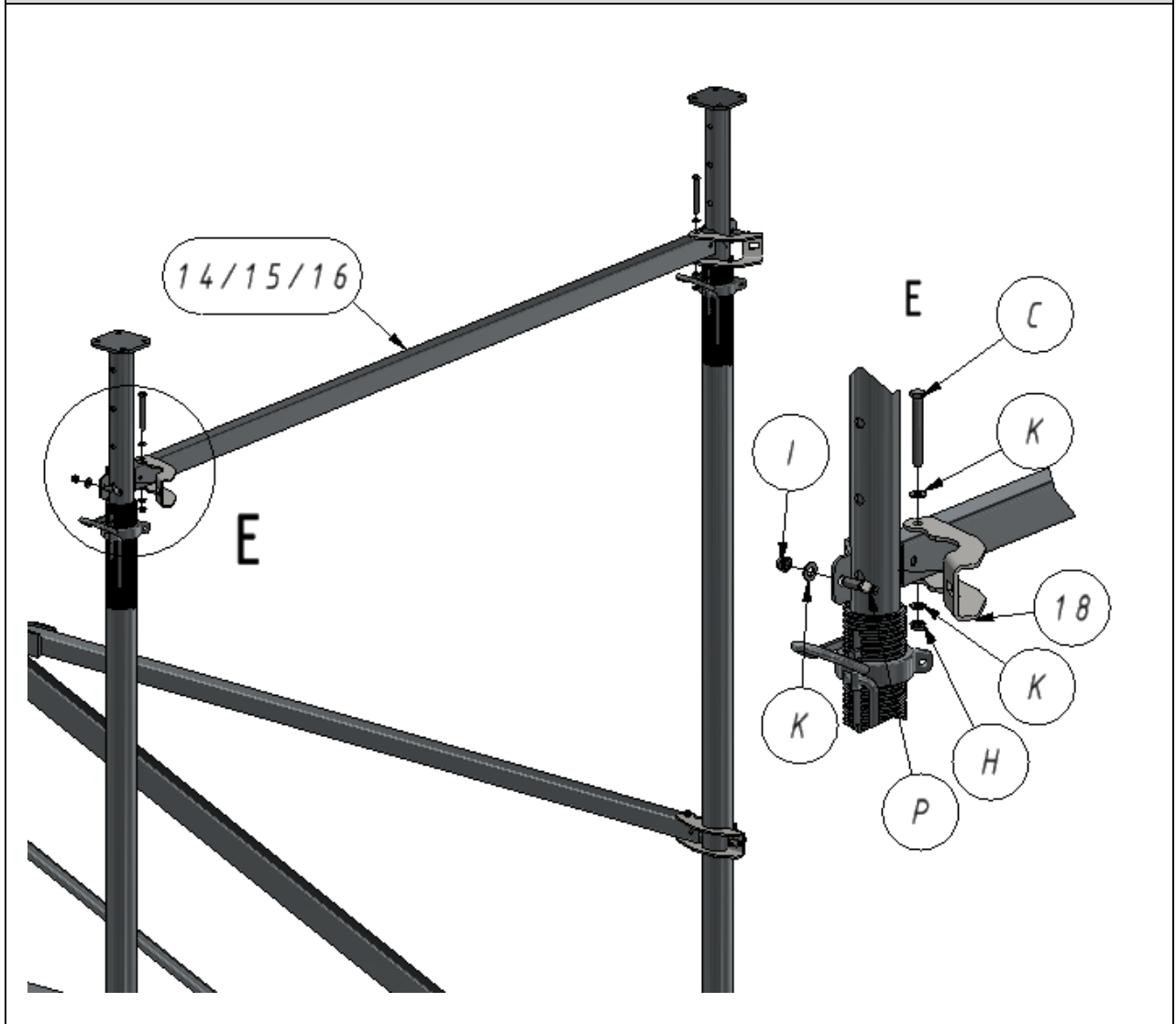

3.7 Ceiling assembly with the use of posts

The clamps fastening the bolt should be screwed loosely, allowing for easy adjustment of the height of the posts. Before tightening, the posts should be positioned perpendicular to the floor and the ceiling. After tightening the posts, tighten the bolt clamps.

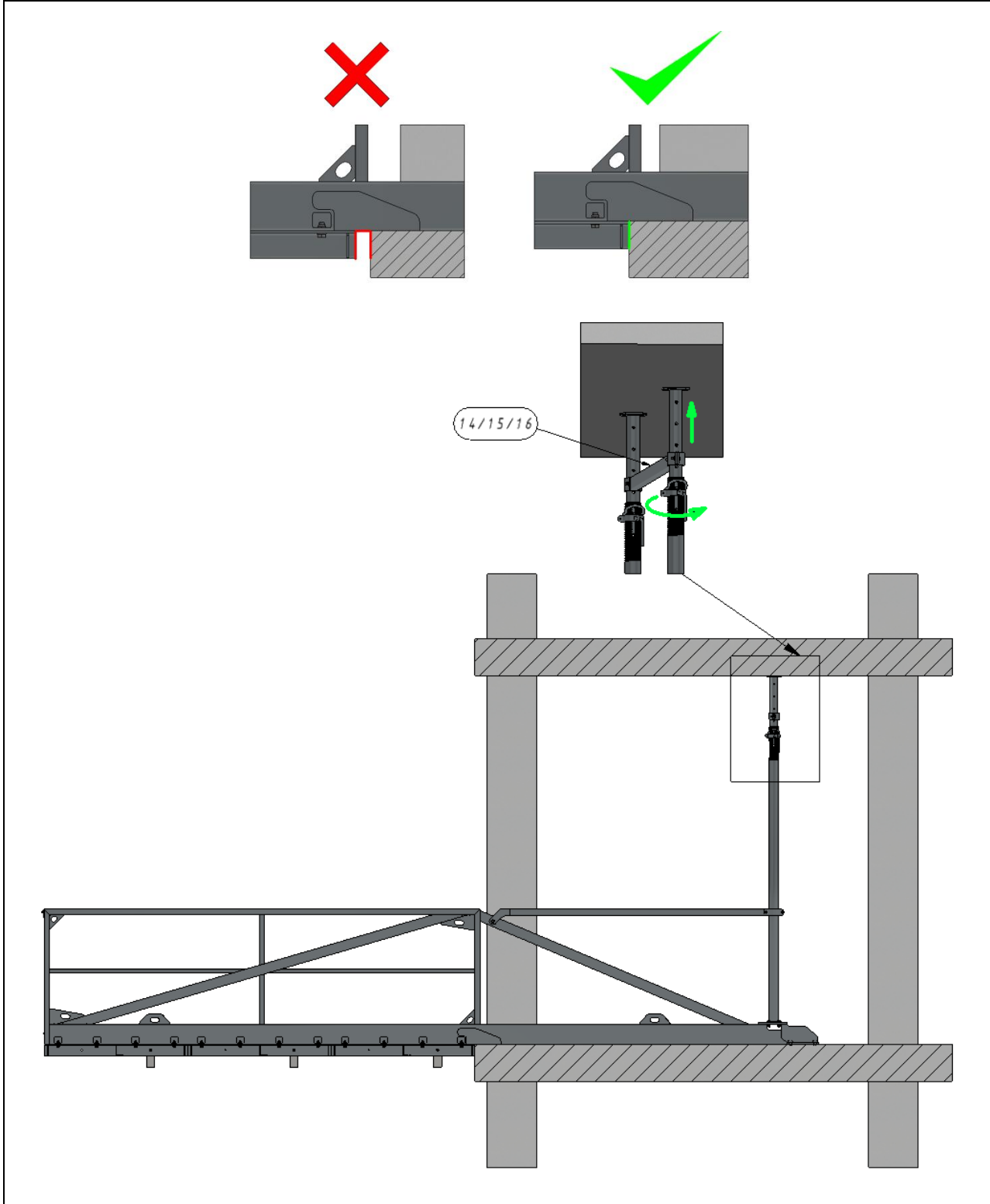

3.8 Ceiling mounting with anchors

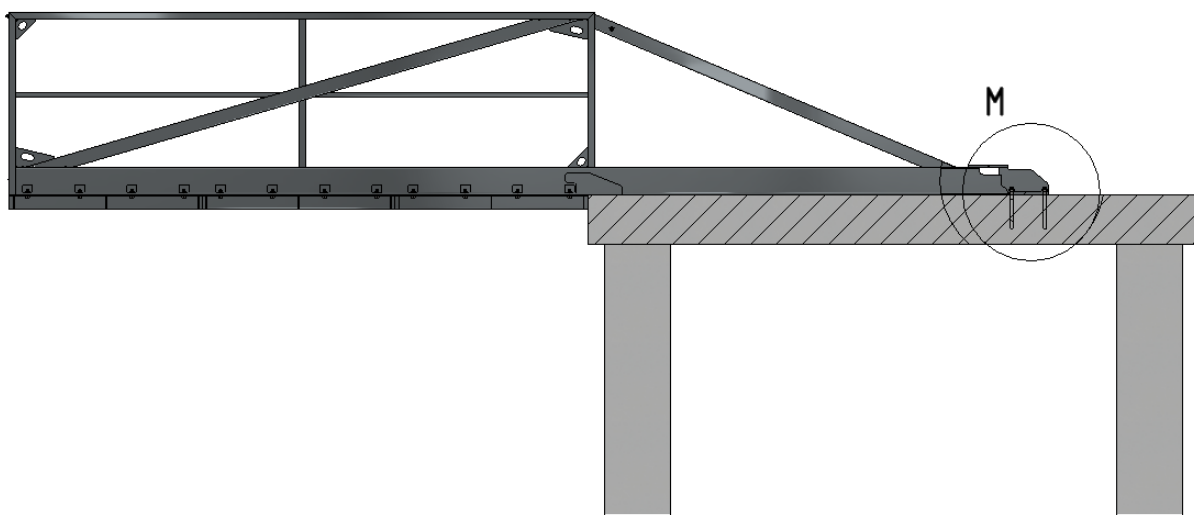
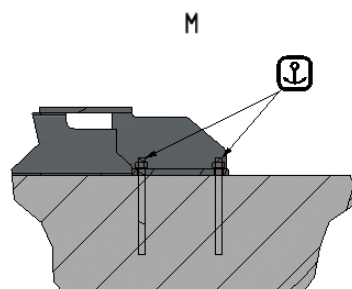
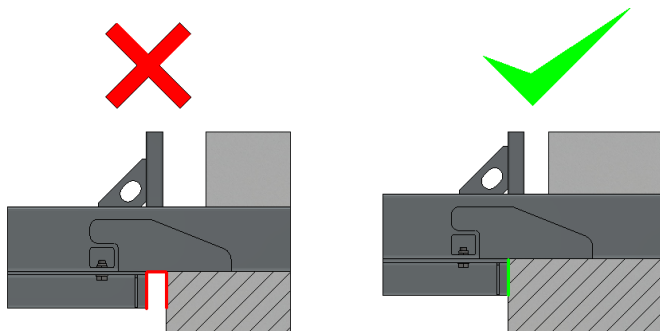

3.9 Assembly of panels on gates

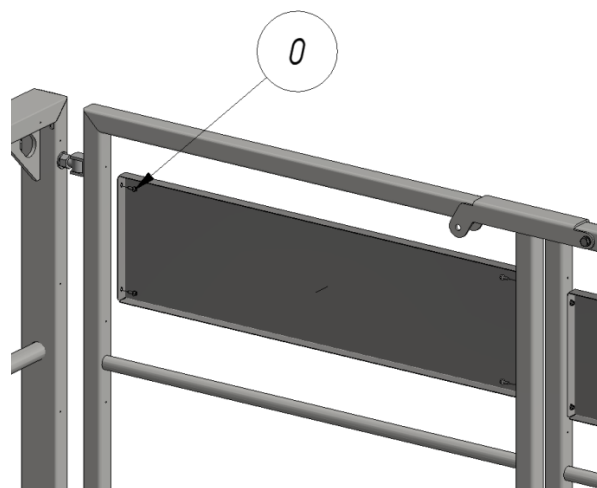
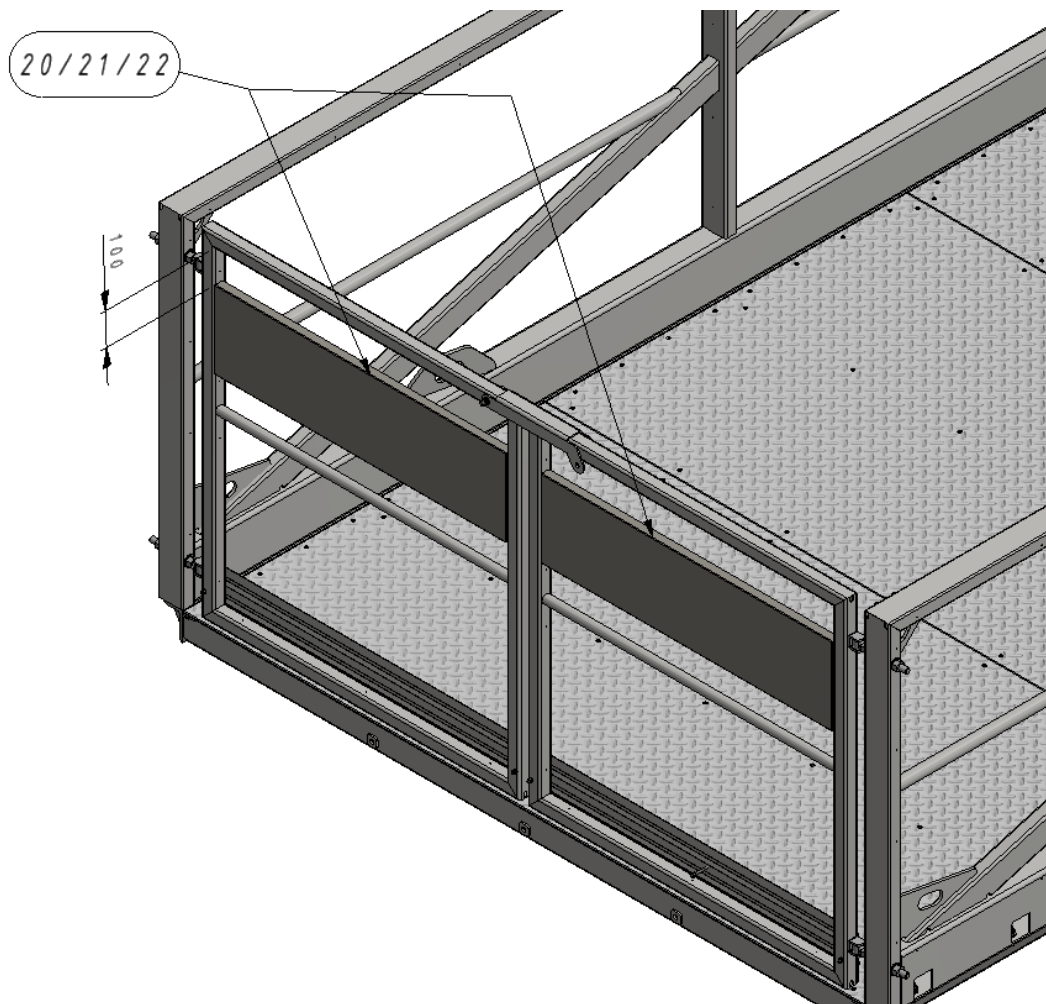

3.10 Assembly of full panels

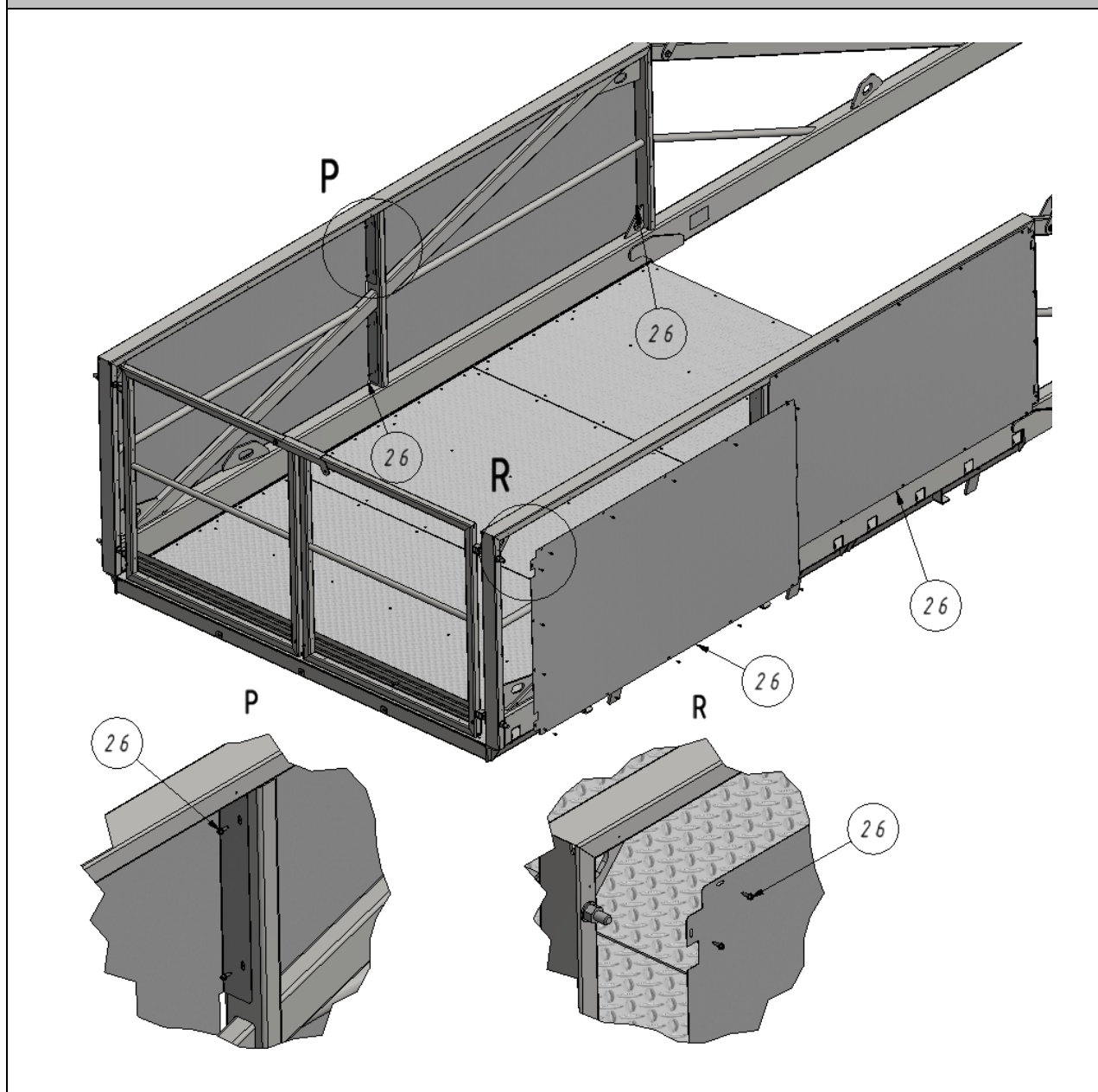

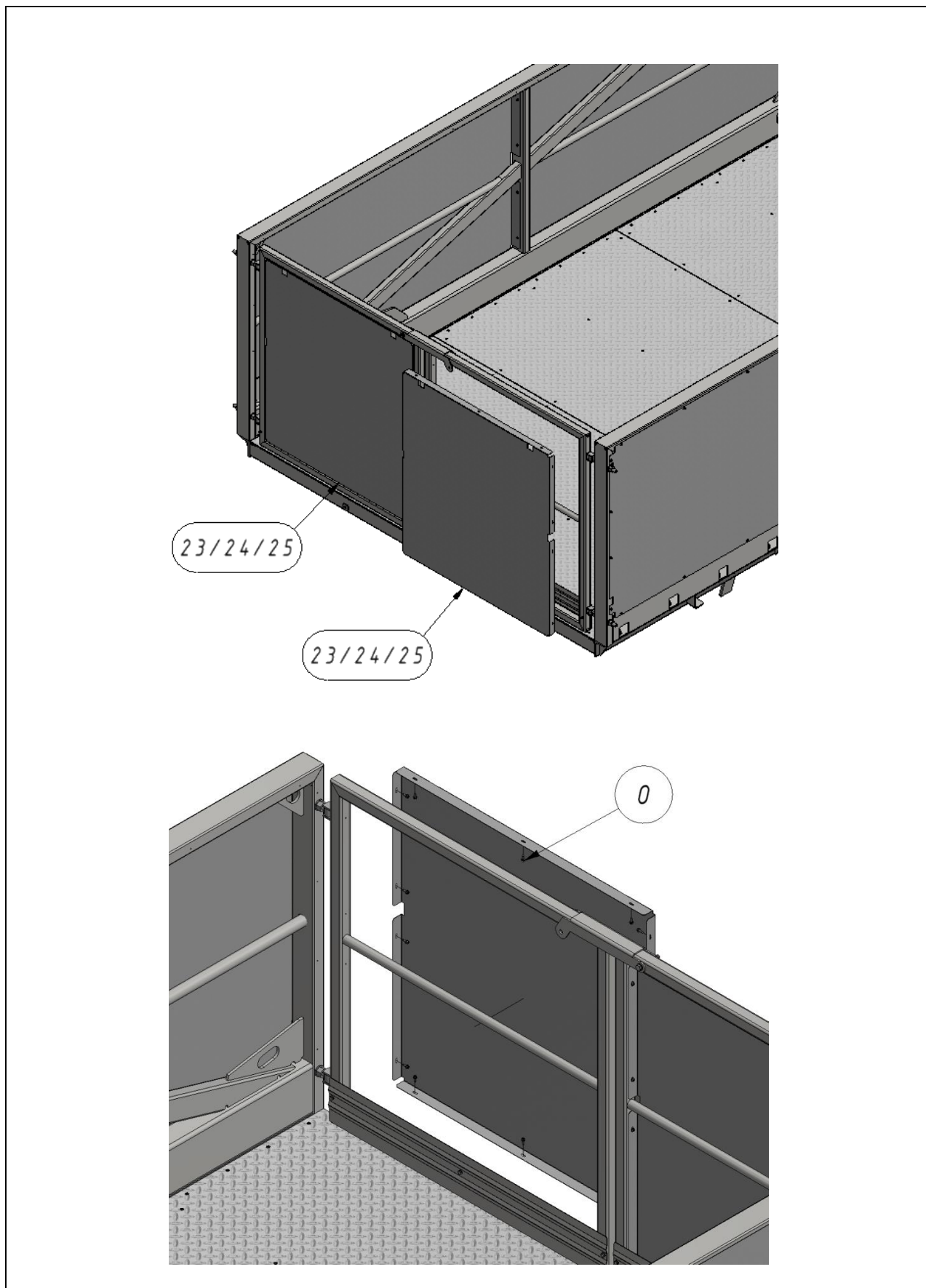

4. Notes

After assembly check:

- If the ceiling (surface) on which the ramp will be assembled is even
- If all bolted connections are tightened with the correct torque for the bolt cross section
- If there are no loose parts
- If the post nuts are properly secured
- If the gate is secured with a screw in the bolt.