

Annex no. 1

Assembly instructions

Aluminum container stairs



Piotr Abram
(Prepared by)

Piotr Abram
(Signature)

Robert Cieśla
(Checked by)

Robert Cieśla
(Signature)

Miłosz Muzyka
(Approved by)

Miłosz Muzyka
(Signature)

Release 2.0, June 2018

Table of contents

1.	Assembly instructions	4
2.	Components of the container stairs system.	10
	Table 1. The list of parts	10
	Table 1. Fasteners.....	11
	Table 1. Elements necessary to adjust the height of the stairs depending on the dimensions of the containers.	11
	Table 2. List of tools	23
4.1.	Assembly: supports	23
4.2.	Assembly of landings	24
4.3.	Assembly: posts	28
4.4.	Assembly : stairs	31
4.5.	Montaż przedłużek schodów Assembly: extension stairs.....	33
4.6.	Assembly: barriers	34
4.7.	Assembly: Connector P-SK3-LP2	39
4.8.	Assembly: safe barriers.....	40
4.9.	Assembly: connector P-SK3-LP5.....	43
4.10.	Montaż stężenia słupów. Assembly:	44

Revisions

Item	NAME AND SURNAME	DEPARTMENT	DATE OF CHANGE	SCOPE OF REVISION	NOTES
1	Piotr Abram	BR	25.06.2018	List of elements, assembly of safe barriers	
2					
3					
4					
5					
6					
7					
8					
9					
10					
11					
12					
13					
14					
15					

1. Assembly instructions

The assembly instructions constitute the annex to the operational and maintenance manuals of the aluminum container stairs system by TLC.

The aluminum container stairs consist of individual elements, as listed in the specification enclosed with the delivery. There are bolted connections and pins in the system. The system is supplied in the form of separate elements, such as platforms, barriers, steps, connectors, stairs and poles. The elements are installed in the specified order.

The aluminum container stairs, as a modular structure, may be freely configured as needed. Setting of the individual configuration should be compliant with the operating and maintenance manuals. The following are 8 basic arrangements of the container stairs.

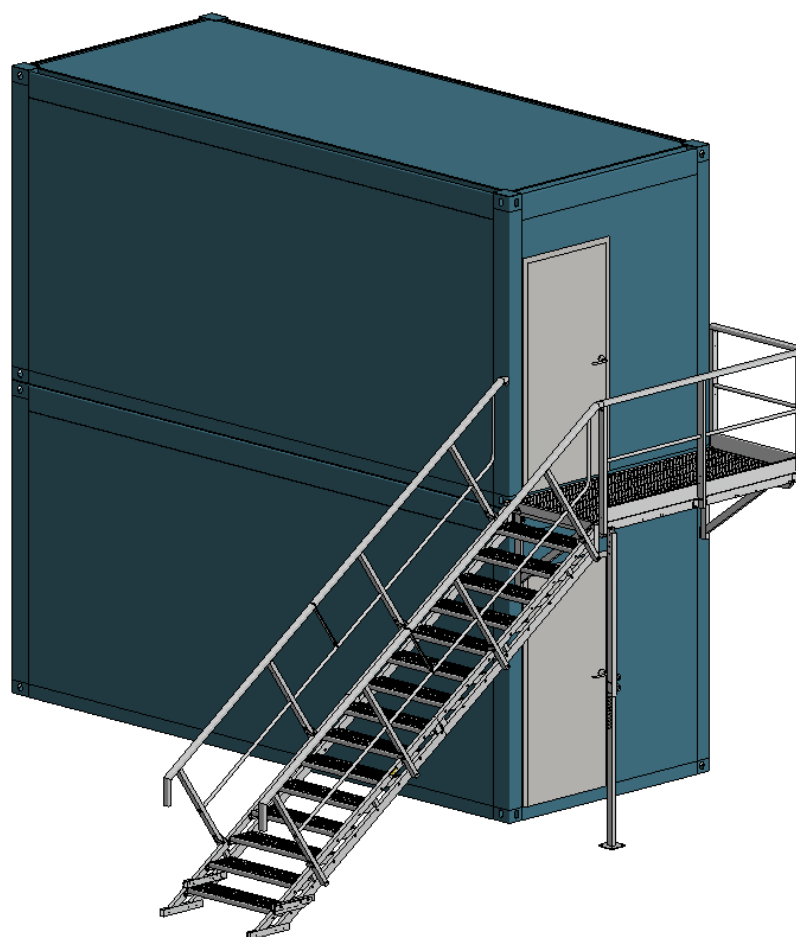

Figure 1. Configuration 1

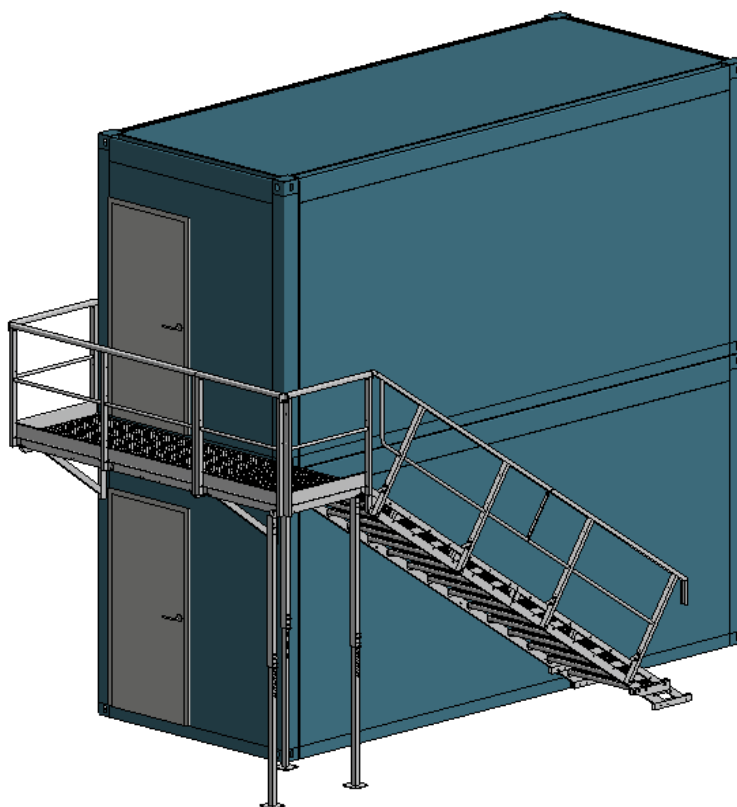

Figure 1. Configuration 3

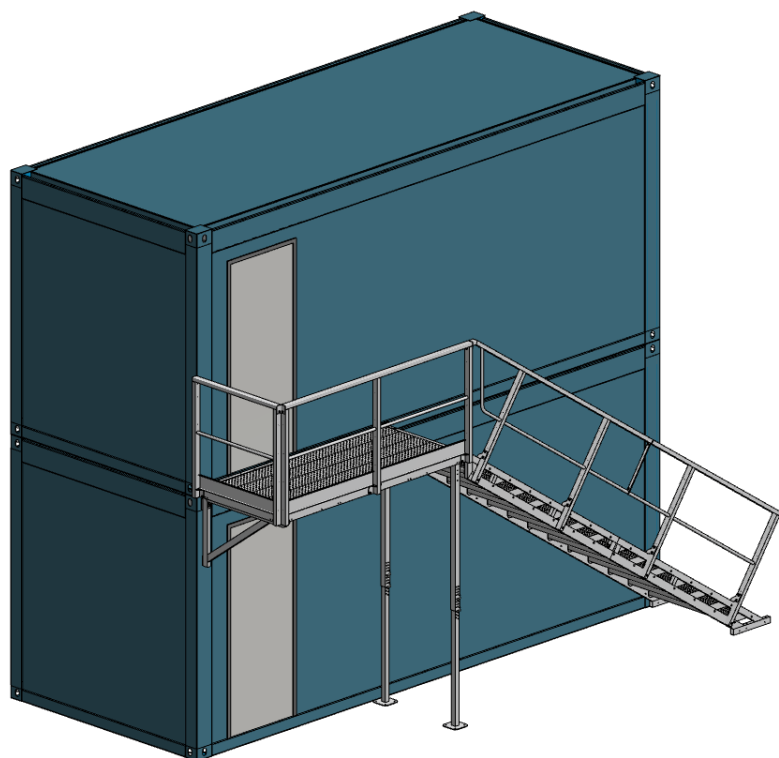

Figure 1. Configuration 4

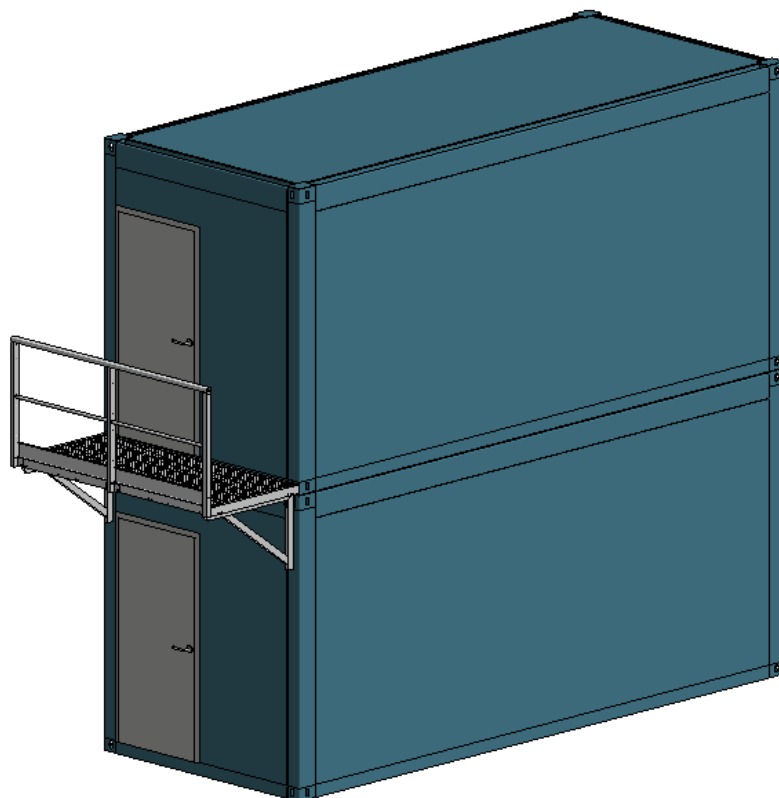

Figure 1. Configuration 5

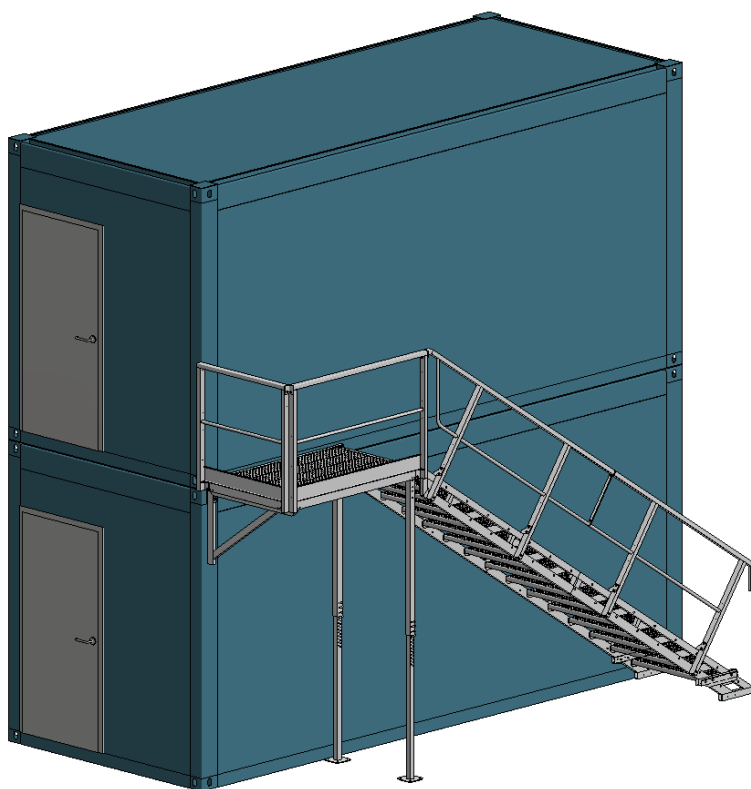

Figure 1. Configuration 6

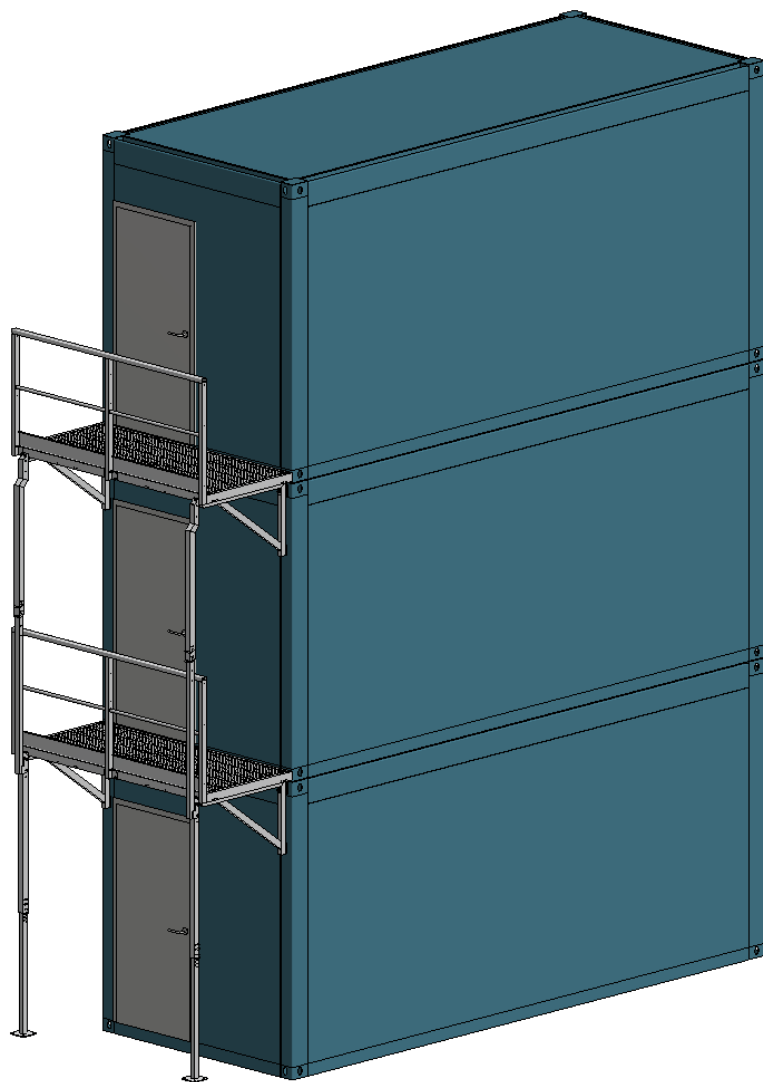

Figure 1. Configuration 7

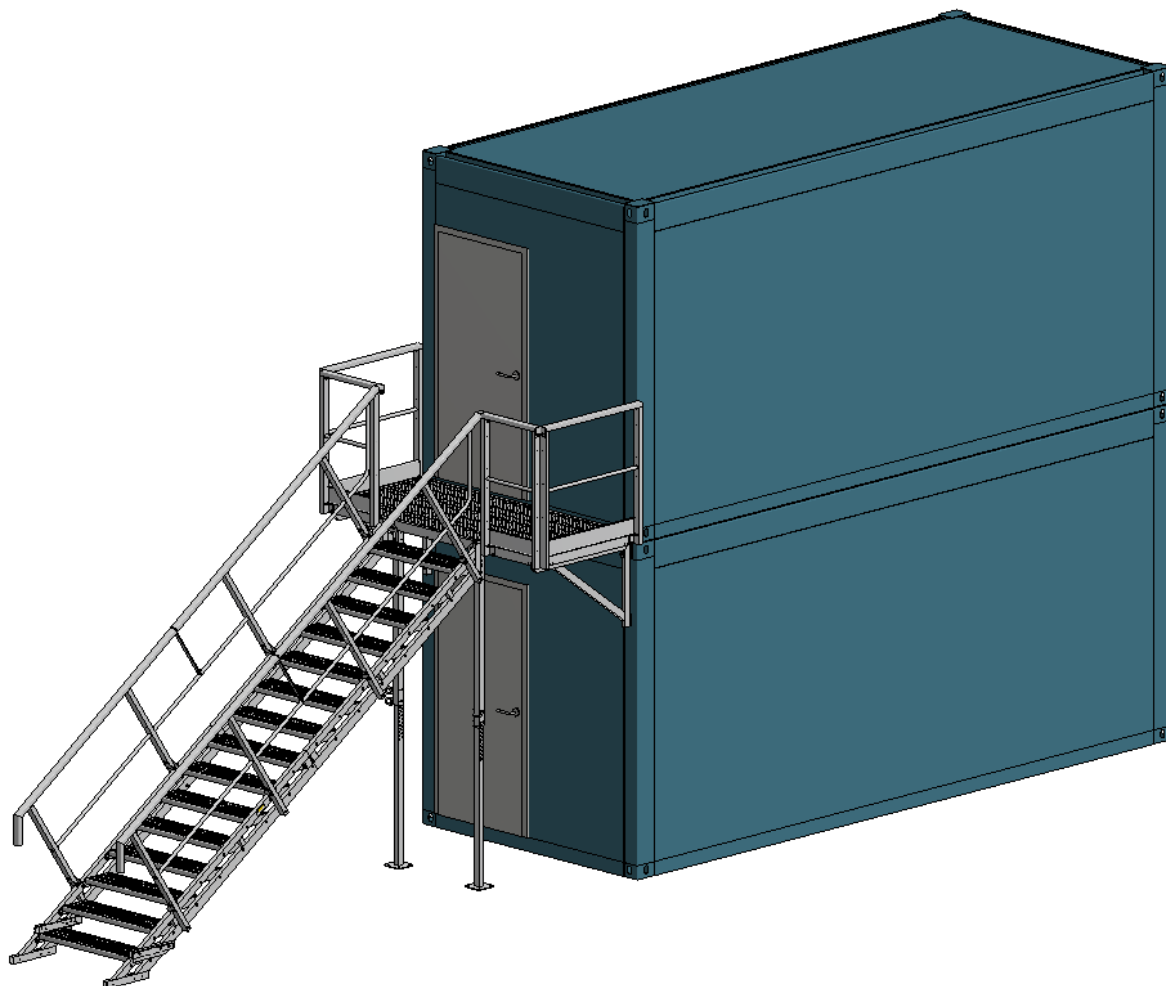

Figure 1. Configuration 8

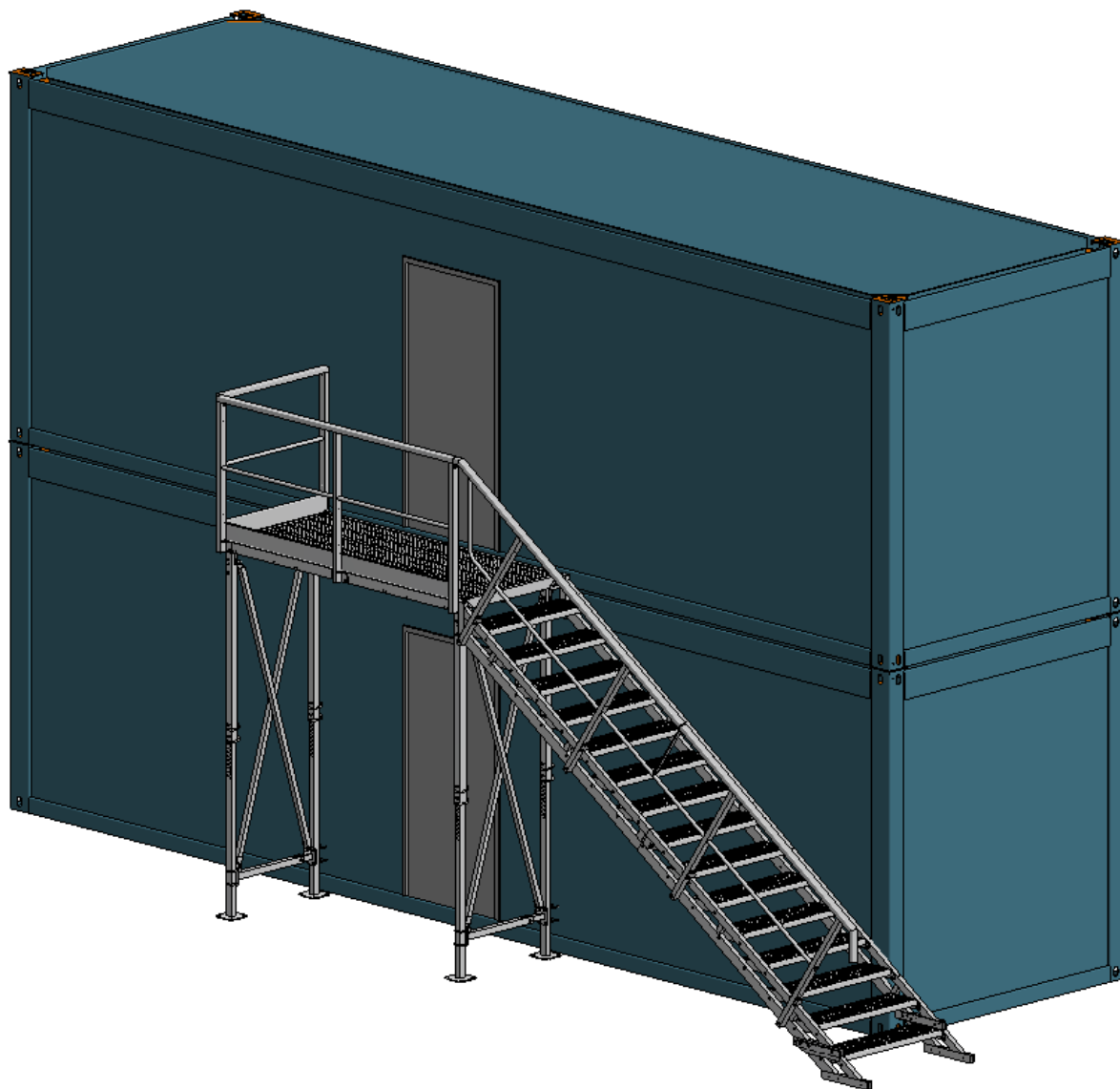

Figure 1. Configuration 10

2. Components of the container stairs system.

The list of elements in Table 1 presents the components of the container stairs system and their quantity installed, depending on the configuration, and the type of the system ordered by the client (to be selected from the code column, description of the component).

Table 1. The list of parts

Item	Code	Description of component	Configuration							
			1	3	4	5	6	7	8	10
Components of the container stairs system										
1.	P-SK3-SB-G	Upper stairs	1	1	1	0	1	0	1	1
2.	P-SK3-SB-D	Lower stairs	1	1	1	0	1	0	1	1
3.	P-SK3-PD1.1-P	Landing 1100x1100 profiled grating	0	1	0	0	0	0	0	0
	P-SK3-PD1.25-P	Landing 1250x1250 profiled grating	0	1	0	0	0	0	0	0
4.	P-SK3-PD2.4-P	Landing 2440x1100 profiled grating	1	1	1	1	0	1	1	1
	P-SK3-PD2.4x1.25-P	Landing 2440x1250 profiled grating	1	1	1	1	0	1	1	1
	P-SK3-PD1.69-P	Landing 1690x1100 profiled grating	0	0	0	0	1	0	0	0
	P-SK3-PD1.69x1.25-P	Landing 1690x1250 profiled grating	0	0	0	0	1	0	0	0
5.	P-SK3-BP0.5	Landing barrier 500 heavy-duty	0	0	0	0	0	0	1	0
	P-SK3-BP0.61	Landing barrier 610 heavy-duty	0	0	0	0	0	0	1	0
6.	P-SK3-BP1.1	Landing barrier 1100 heavy-duty	1	3	1	0	1	0	2	1
7.	P-SK3-BP1.25	Landing barrier 1250 heavy-duty	1	3	1	0	1	0	2	1
8.	P-SK3-BP2.4	Landing barrier 2440 heavy-duty	1	1	1	1	0	1	1	1
	P-SK3-BP1.69	Landing barrier 1690 heavy-duty	0	0	0	0	1	0	0	0
9.	P-SK3-BS-DL	Heavy-duty lower left barrier stairs	1	1	1	0	1	0	1	1
10.	P-SK3-BS-DP	Heavy-duty right lower barrier stairs	1	1	1	0	1	0	1	1
11.	P-SK3-BS-GL	Heavy-duty upper left barrier stairs	1	1	1	0	1	0	1	1
12.	P-SK3-BS-GP	Heavy-duty upper right barrier stairs	1	1	1	0	1	0	1	1
13.	P-SK3-PR1	Post 01	1	3	2	0	2	2	2	4
14.	P-SK3-PR2	Post 01	0	0	0	0	0	2	0	0
15.	P-SK3-WT1.1	Landing support 1100	2	2	1	2	1	2	2	0
	P-SK3-WT1.25	Landing support 1250	2	2	1	2	1	2	2	0
16.	P-SK3-O1	Concentration cross rail	0	0	0	0	0	0	0	2
17.	P-SK3-X1	Concentration	0	0	0	0	0	0	0	4
18.	P-SK3-A1	Concentration connector	0	0	0	0	0	0	0	4
19.	P-SK3-LP1	Barrier connector	1	2	1	0	1	0	2	1
20.	P-SK3-LP2	Landing-container connector 01	0	0	1	0	1	0	0	2
	P-SK3-LP3	Landing-container connector 01	0	0	1	0	1	0	0	2
21.	P-SK3-LP4	Barriers filling connector	0	0	0	0	0	0	2	0
22.	P-SK3-LP5	Barrier connector	0	0	0	0	0	0	2	0
23.	P-SK3-LP-SB1	Lower stairs connector	2	2	2	0	2	0	2	2

24.	P-SK3-LP-SB2	Upper stairs connector	2	2	2	0	2	0	2	2
25.	P-SK3-ZW	Bracket clamp	2	2	1	2	1	2	2	0
26.	P-SK3-BP0.5-P	Barrier panel 500	0	0	0	0	0	0	2	0
27.	P-SK3-BP0.61-P	Barrier panel 610	0	0	0	0	0	0	2	0
28.	P-SK3-BP1.1-P	Barrier panel 1100	1	3	1	0	1	0	2	1
29.	P-SK3-BP1.25-P	Barrier panel 1250	1	3	1	0	1	0	2	1
30.	P-SK3-BP2.4-P	Barrier panel 2440	2	2	2	2	0	2	2	2
31.	P-SK3-BP1.69-P	Barrier panel 1690	0	0	0	0	1	0	0	0
32.	P-SK3-BS-P1	Staircase barrier panel P1	4	2	4	0	4	0	4	4
33.	P-SK3-BS-P3	Staircase barrier panel P3	2	1	2	0	2	0	2	2
34.	P-SK3-BS-P2L	Staircase barrier panel P2L	1	0	1	0	1	0	1	1
35.	P-SK3-BS-P2P	Staircase barrier panel P2P	1	1	1	0	1	0	1	1

Table 1. Fasteners

Item	Code	Description of components	Configuration							
			1	3	4	5	6	7	8	10
Fasteners										
A.	ISO 4014 M10x100 A2	Bolt M10x100 A2	12	21	12	8	10	20	14	12
B.	ISO 4014 M10x120 A2	Bolt M10x120 A2	8	4	4	0	4	0	8	4
C.	ISO 4014 M10x80 A2	Bolt M10x80 A2	8	8	8	0	8	0	12	12
D.	ISO 4014 M10x60 A2	Bolt M10x60 A2	15	17	9	4	7	16	14	13
E.	ISO 4017 M10x30 A2	Bolt M10x30 A2	0	0	0	0	0	0	0	2
F.	ISO 4014 M12x160 A2	Bolt M12x160 A2	2	2	2	0	2	0	2	2
G.	ISO 4014 M12x90 A2	Bolt M12x90 A2	0	0	0	0	0	4	0	0
H.	ISO 4017 M12x30 A2	Bolt M12x30 A2	0	0	0	0	0	0	0	8
I.	ISO 4032 M10 A2	Nut M10 A2	47	52	35	12	31	36	54	43
J.	ISO 4032 M12 A2	Nut M12 A2	2	2	2	0	2	4	2	10
K.	ISO 7089 10	Washer 10 A2	94	104	70	24	62	72	108	86
L.	ISO 7089 12	Washer 12 A2	0	0	0	0	0	8	0	16
M.	ISO 9021 10	Extended washer 12 A2	4	4	4	0	4	0	4	4
R.	DIN 7504 K	Self-drilling screw A2 4,2x20	100	116	100	16	76	32	108	100

Table 1. Elements necessary to adjust the height of the stairs depending on the dimensions of the containers.

Item	Code	Description	Container H=2591	Container H=2800	Container H=2900
2-1	P-SK3-SB-FS1	Stairs extension 01 right	0	1	0
3-1	P-SK3-SB-FS2	Stairs extension 02 right	0	0	1
N.	ISO 4032 M10 A2	Nut M10 A2	0	6	6
O.	ISO 7089 M10	Washer 10 A2	0	12	12
P.	ISO 4017 M10x60 A2	Bolt M10x60 A2	0	6	6

Table 1. Components of the container stairs system.

P-SK3-SB-G

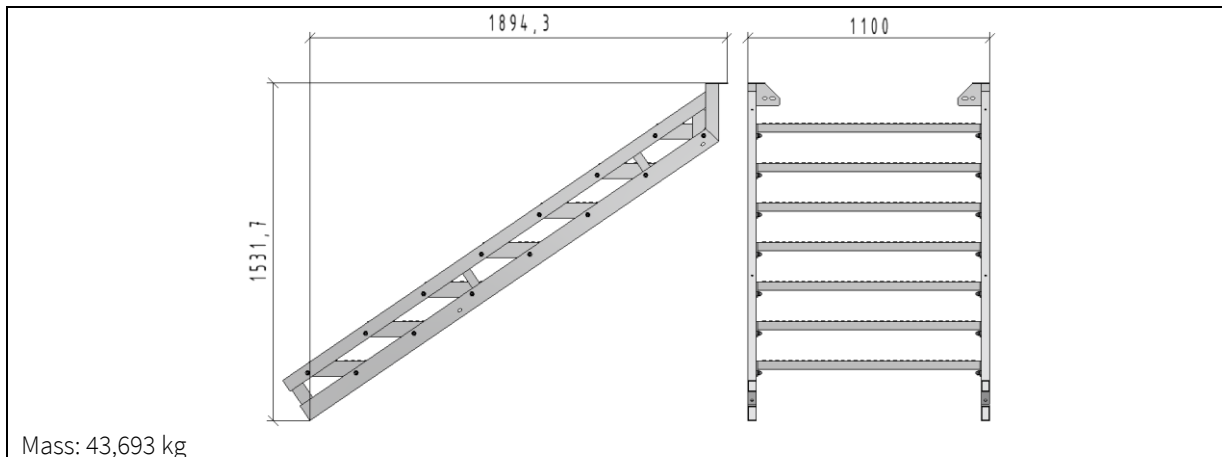

Mass: 43,693 kg

P-SK3-SB-D

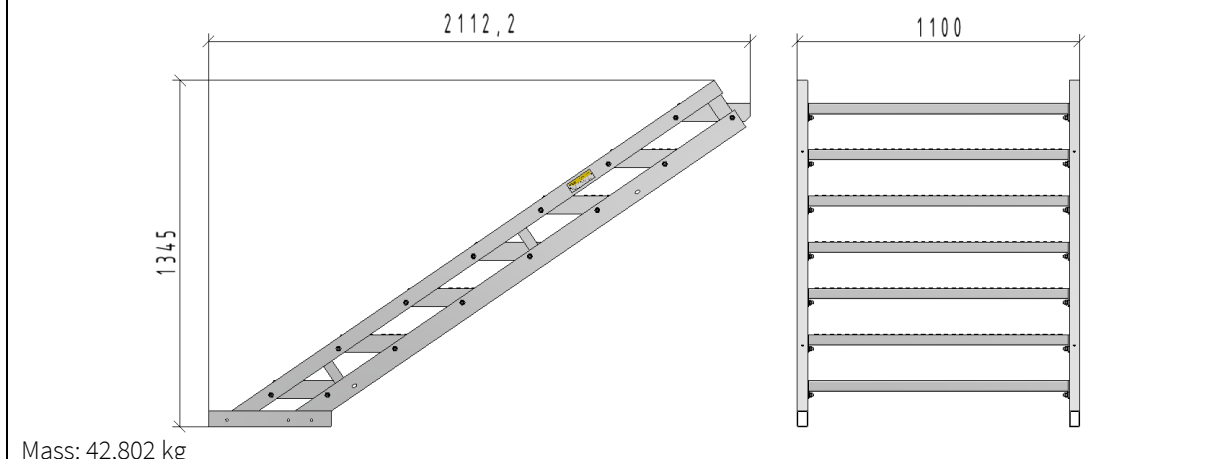

Mass: 42,802 kg

P-SK3-PD1.1-P

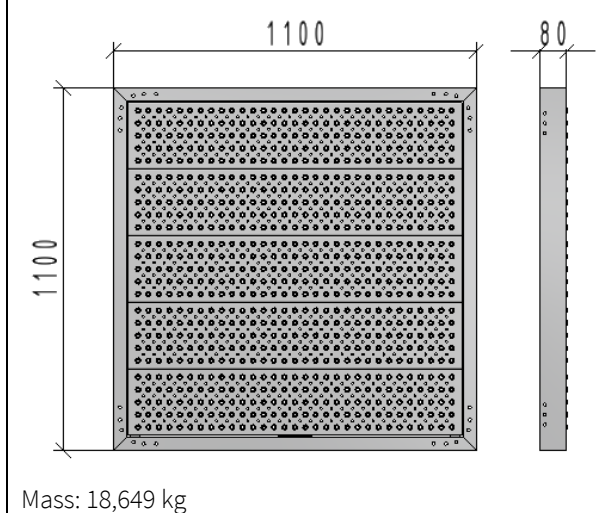

Mass: 18,649 kg

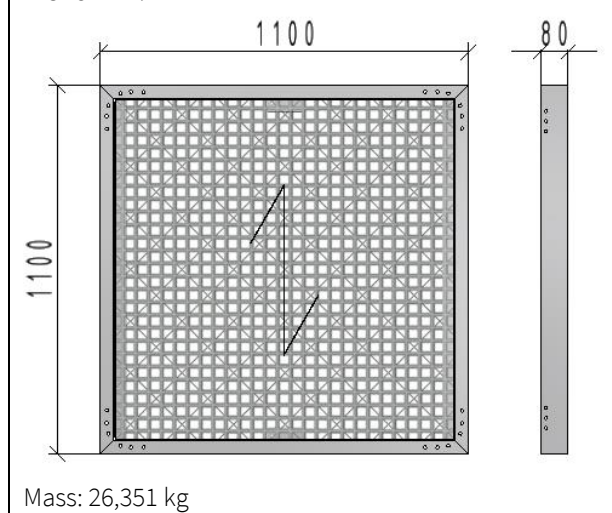

Mass: 26,351 kg

P-SK3-PD-1.25-P

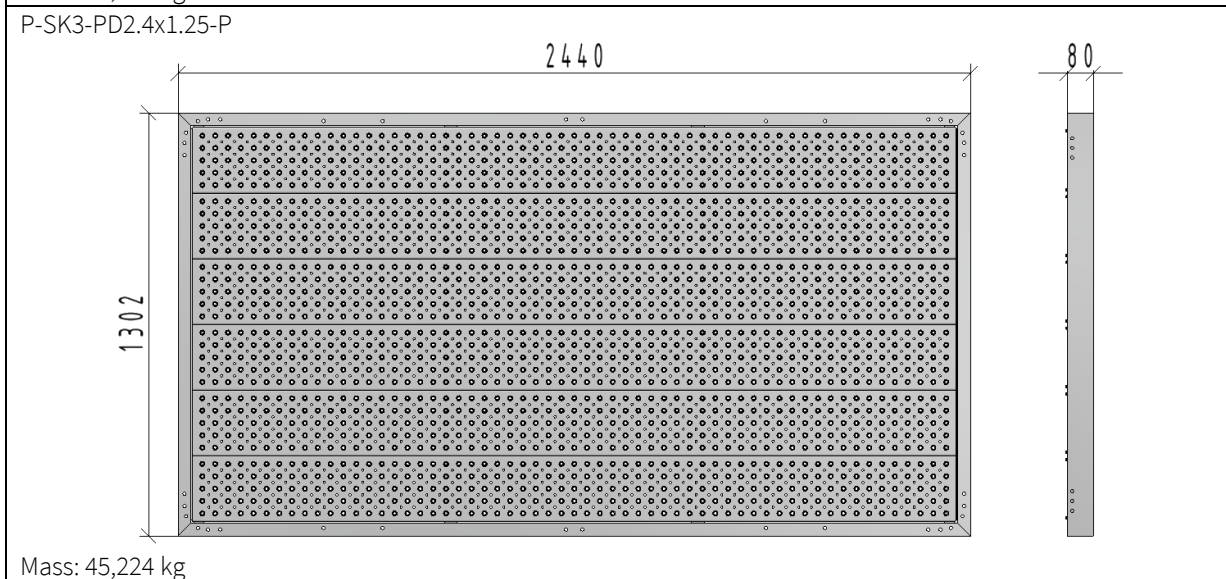
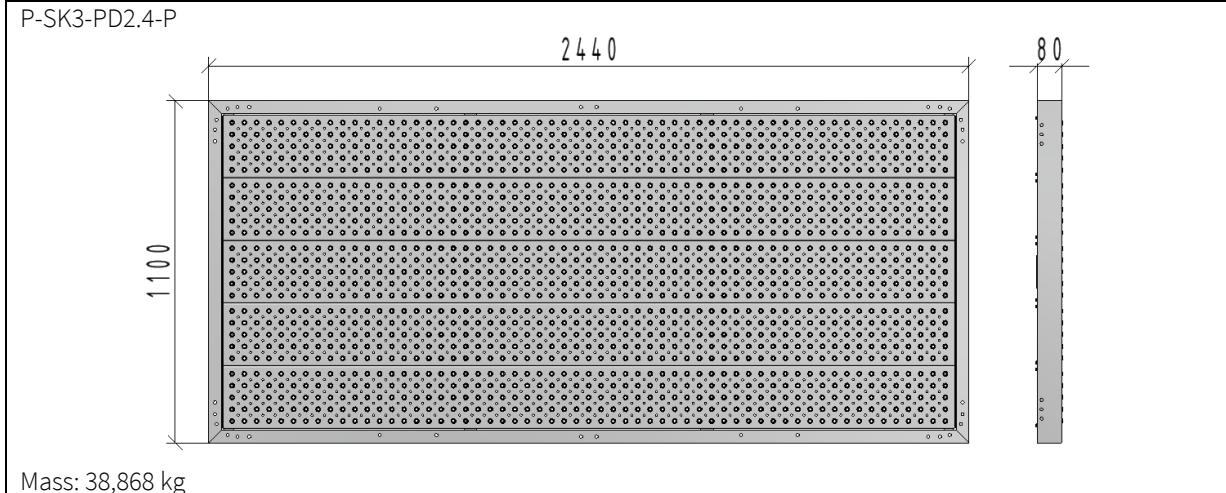
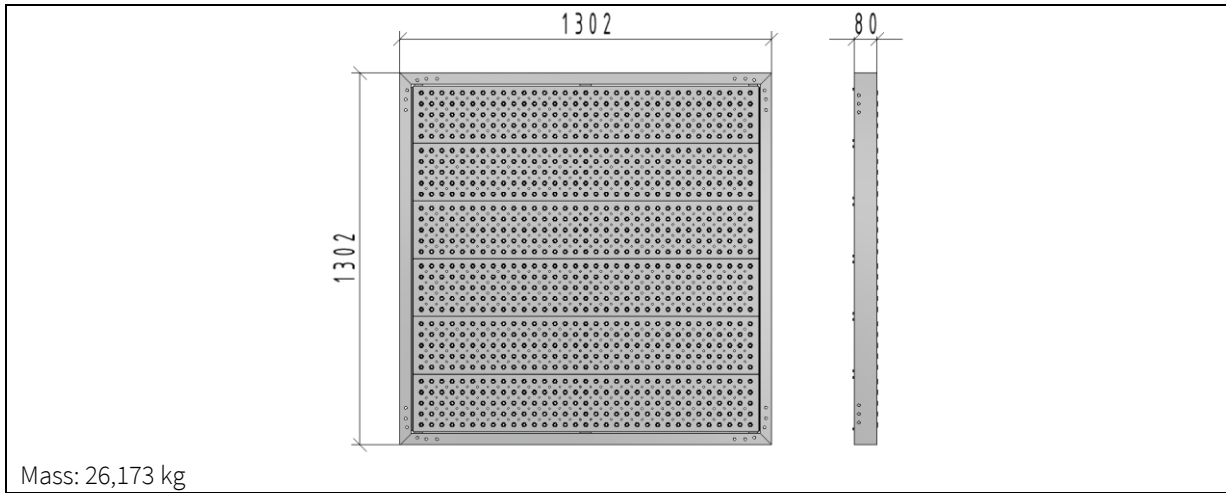

P-SK3-PD1.69-P

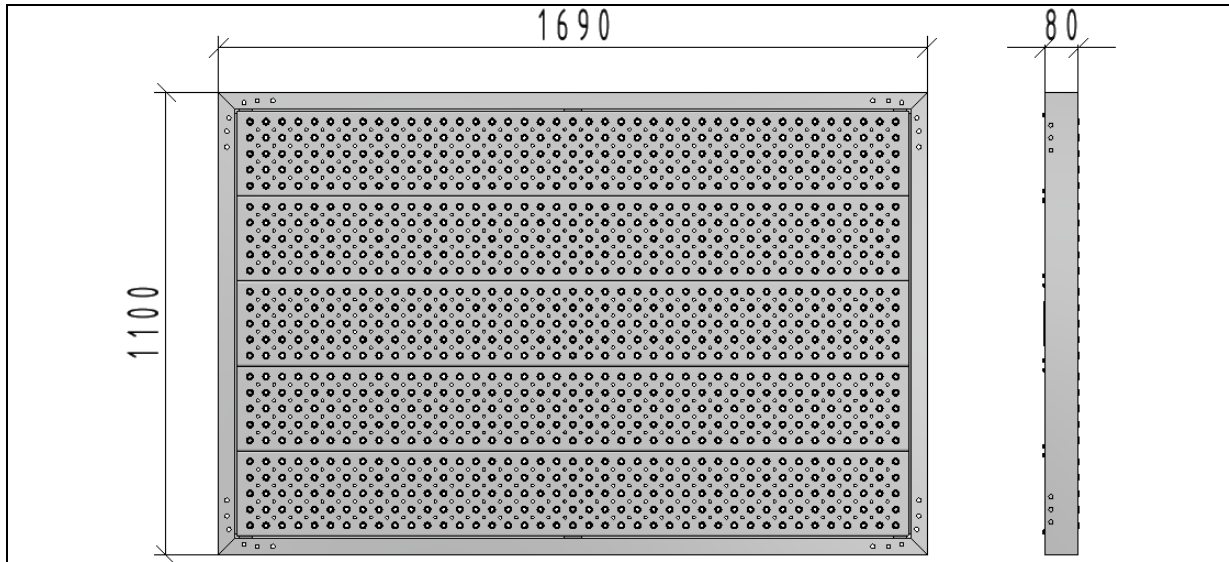

Mass: 27,854 kg

P-SK3-PD1.69x1.25-P

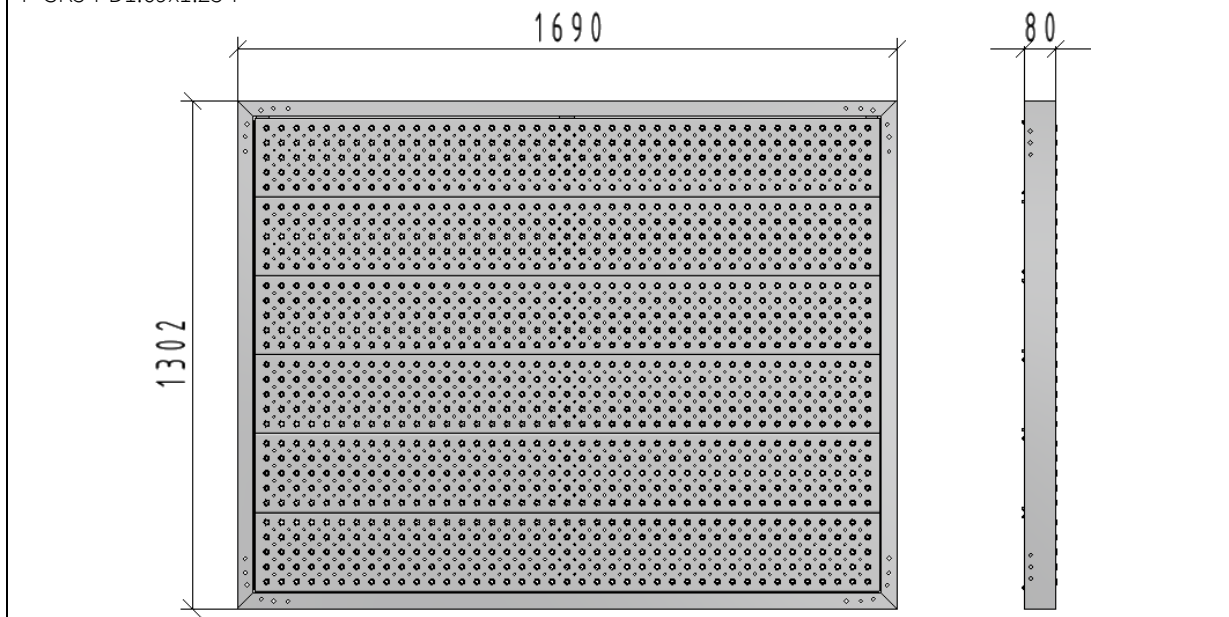

Mass: 32,183 kg

P-SK3-BP0.5

P-SK3-BP0.5-P

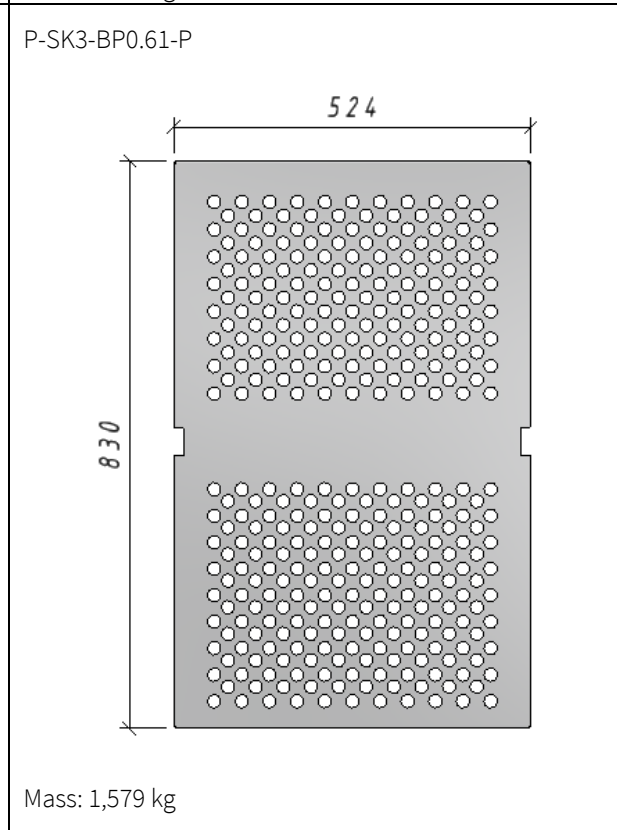
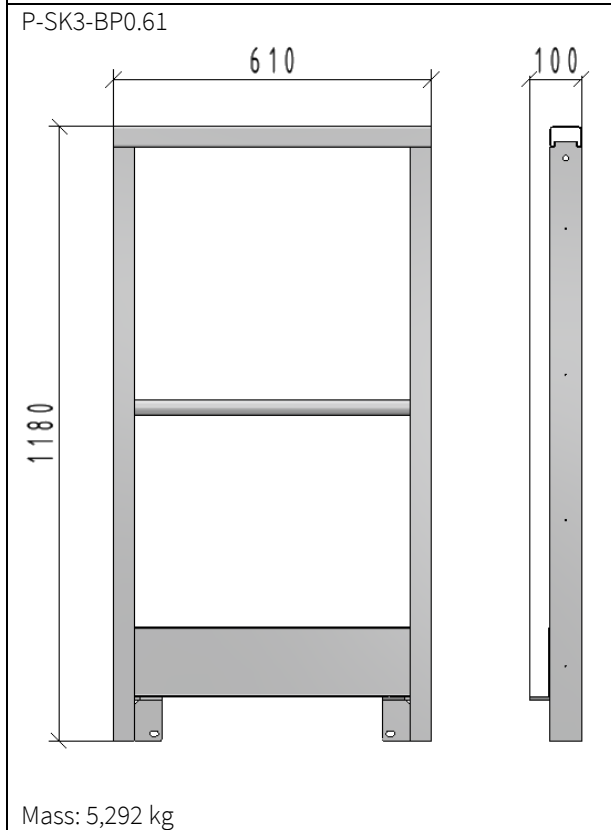
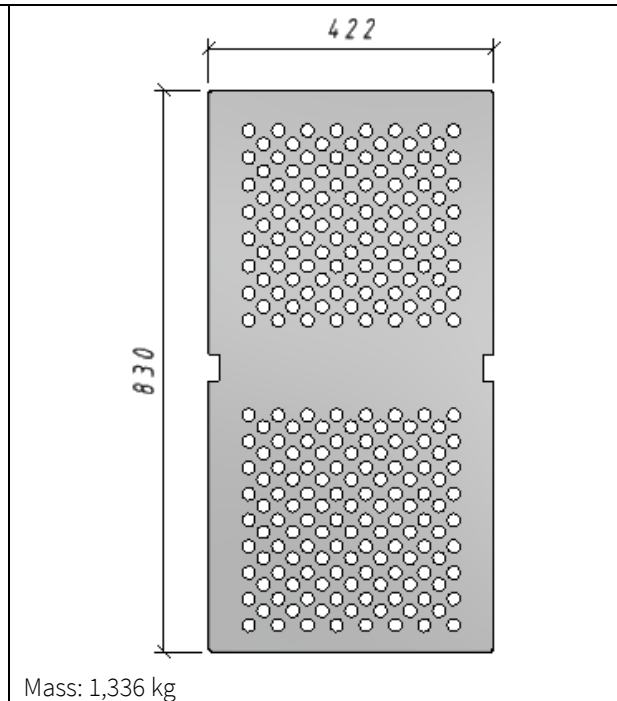
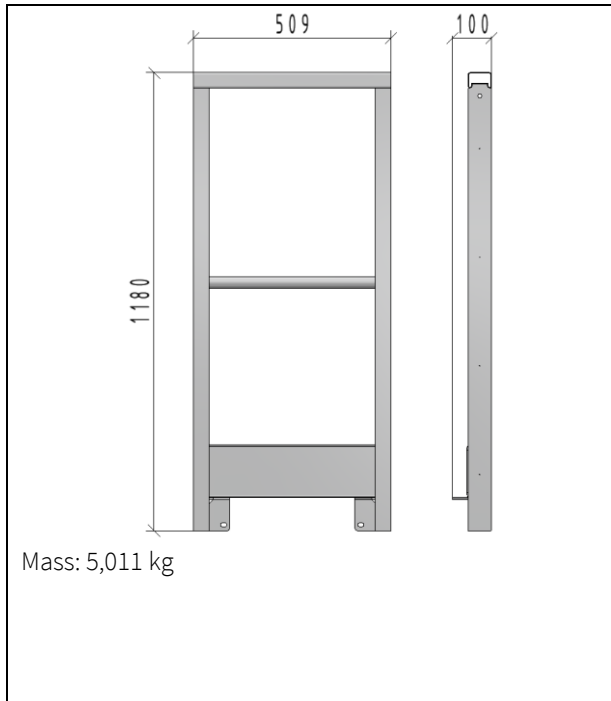

P-SK3-BP1.1

P-SK3-BP1.1-P

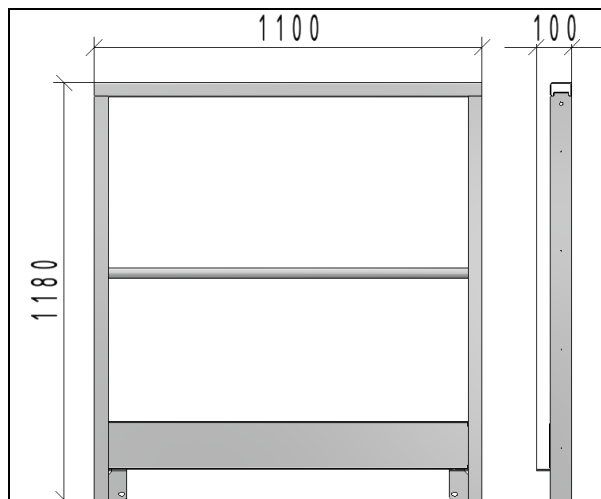

Mass: 6,657 kg

P-SK3-BP1.25

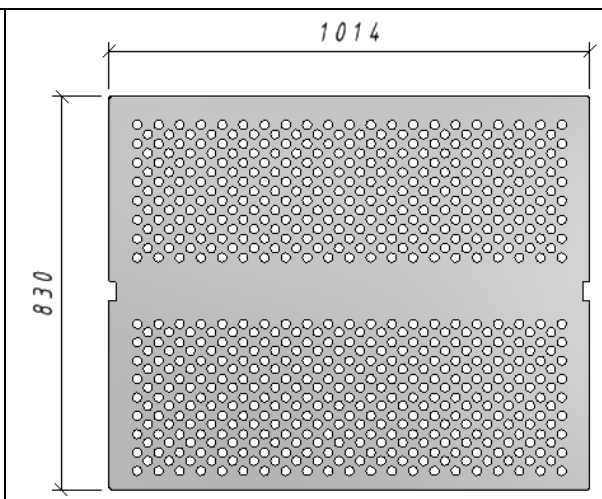

Mass: 2,923 kg

P-SK3-BP1.25-P

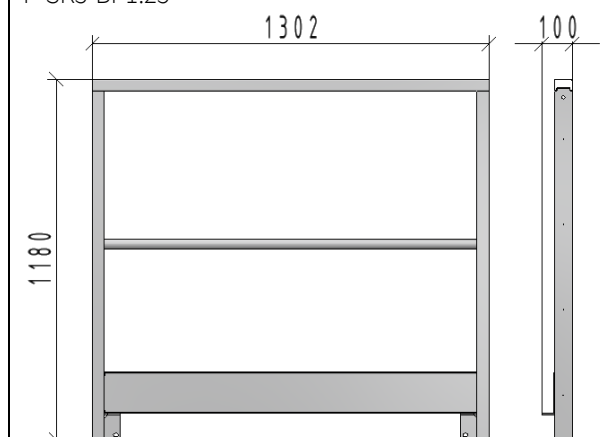

Mass: 7,219 kg

P-SK3-BP2.4

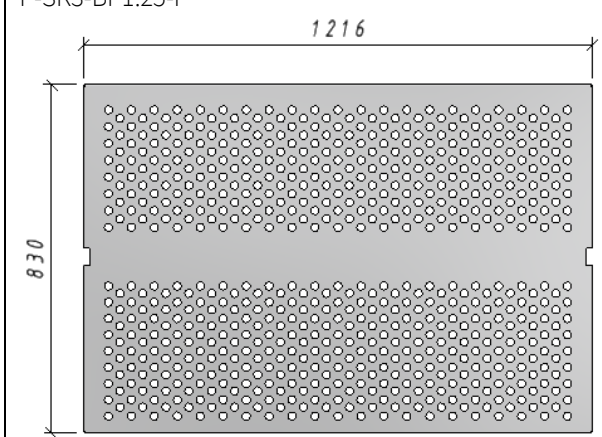

Mass: 3,645 kg

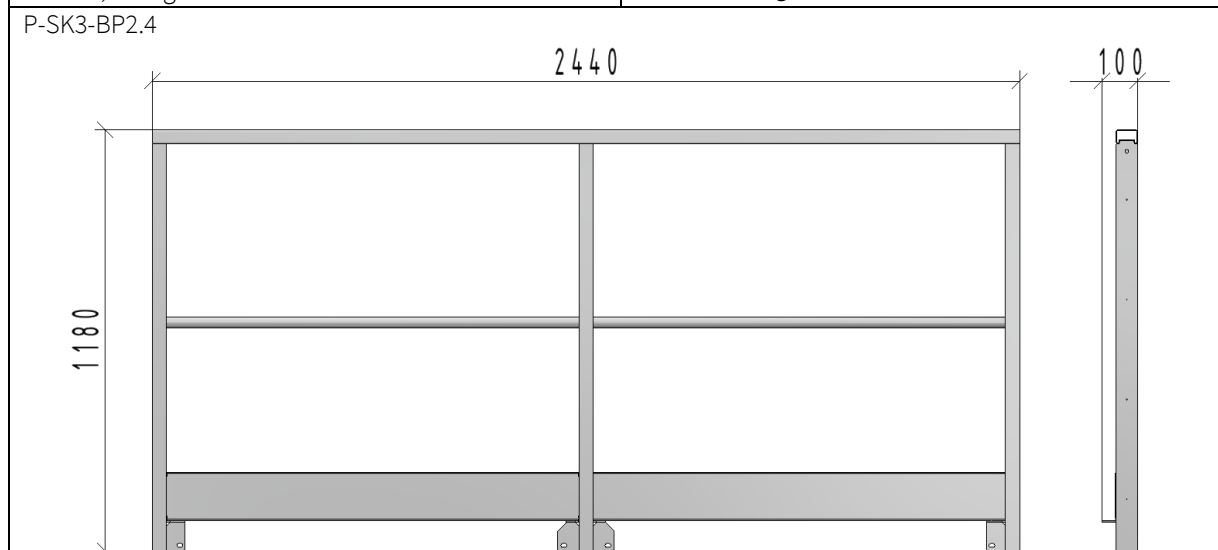

Mass: 12,303 kg

P-SK3-BP2.4-P

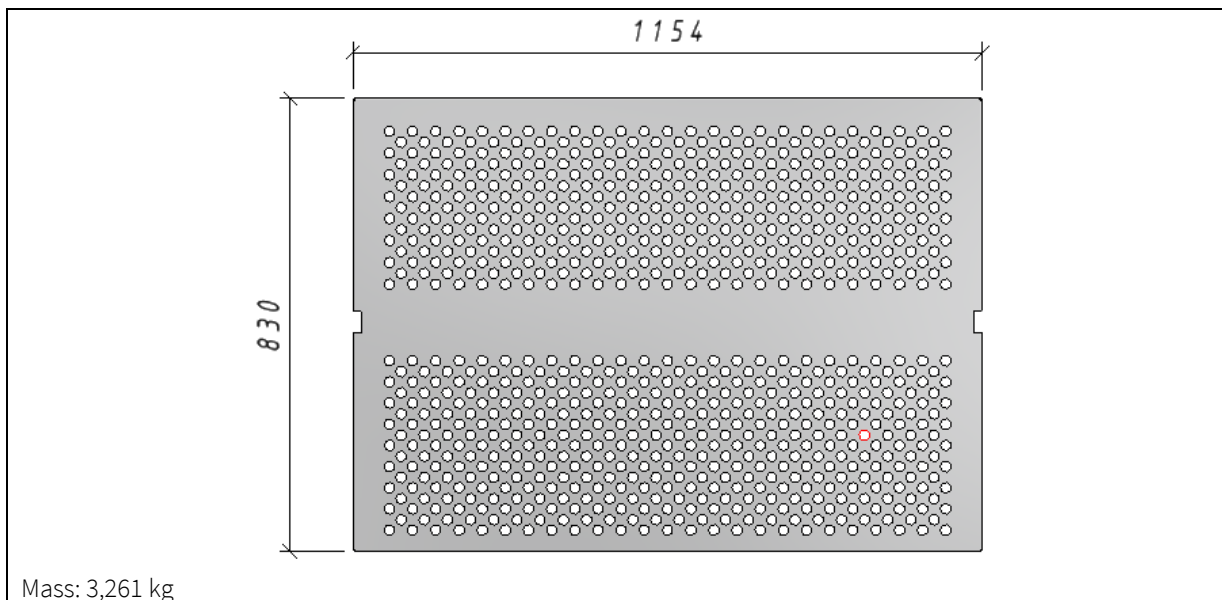

P-SK3-BP1.69

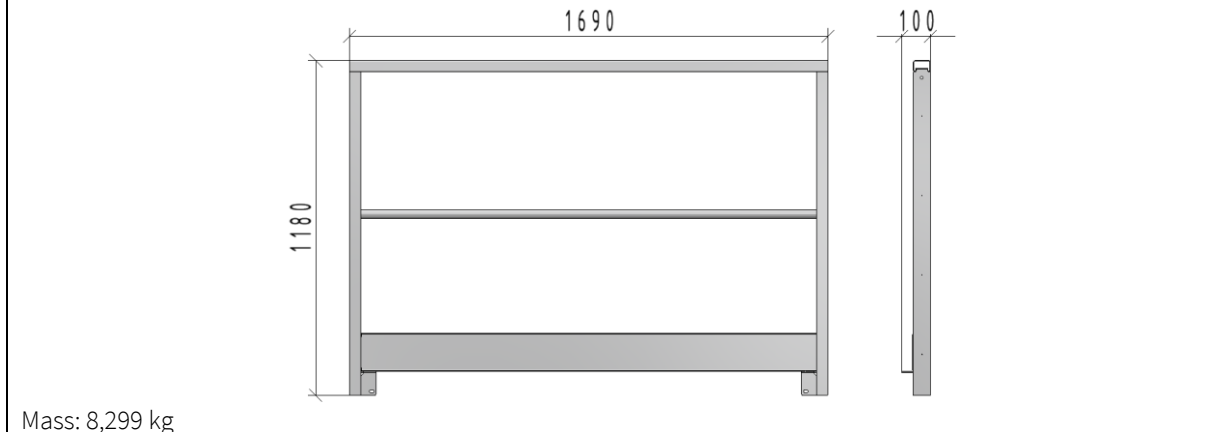

P-SK3-BP1.69-P

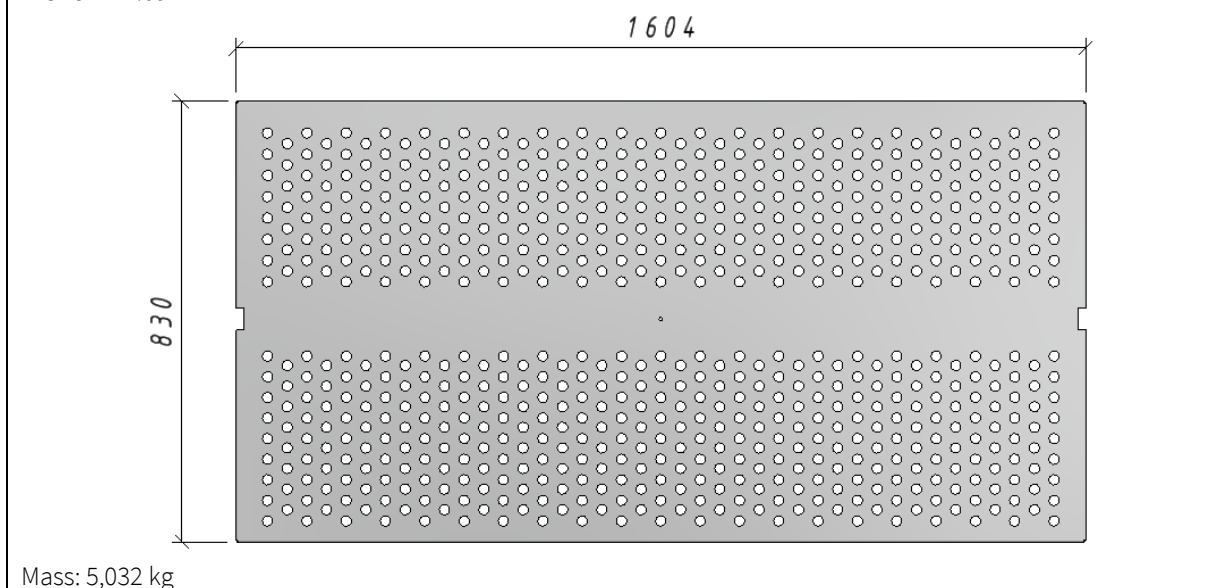

P-SK3-BS-DL

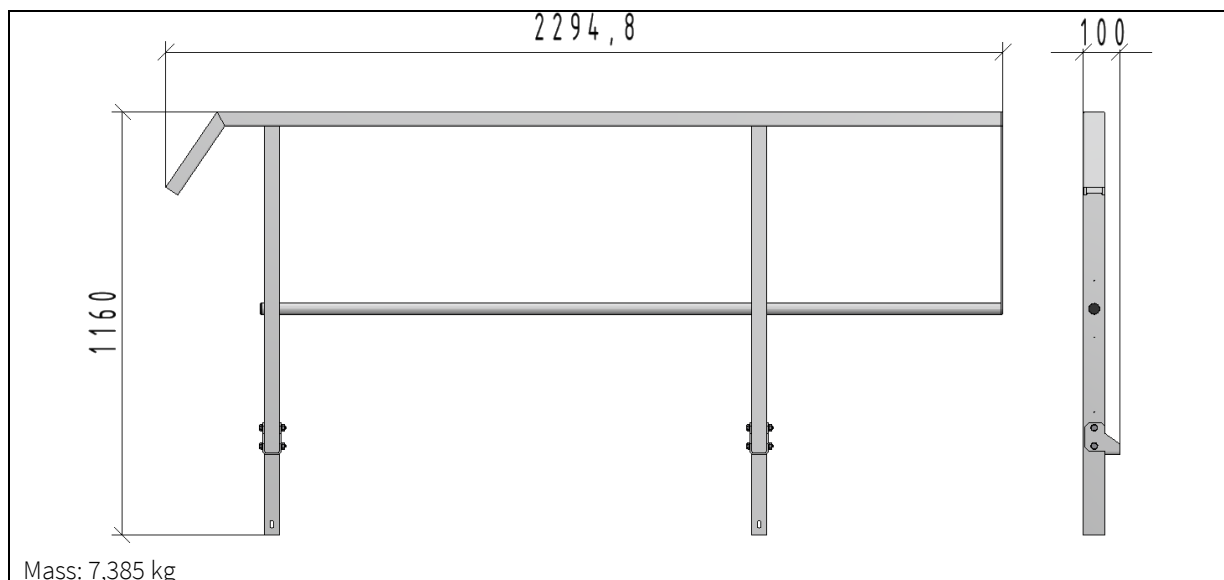

P-SK3-BS-DP

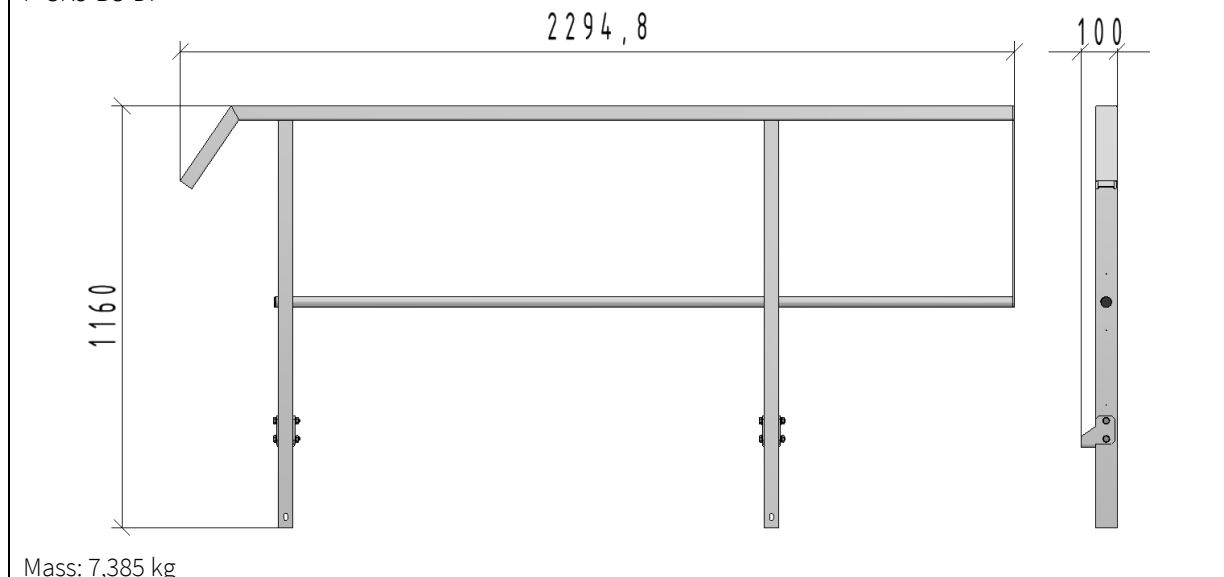

P-SK3-BS-GL

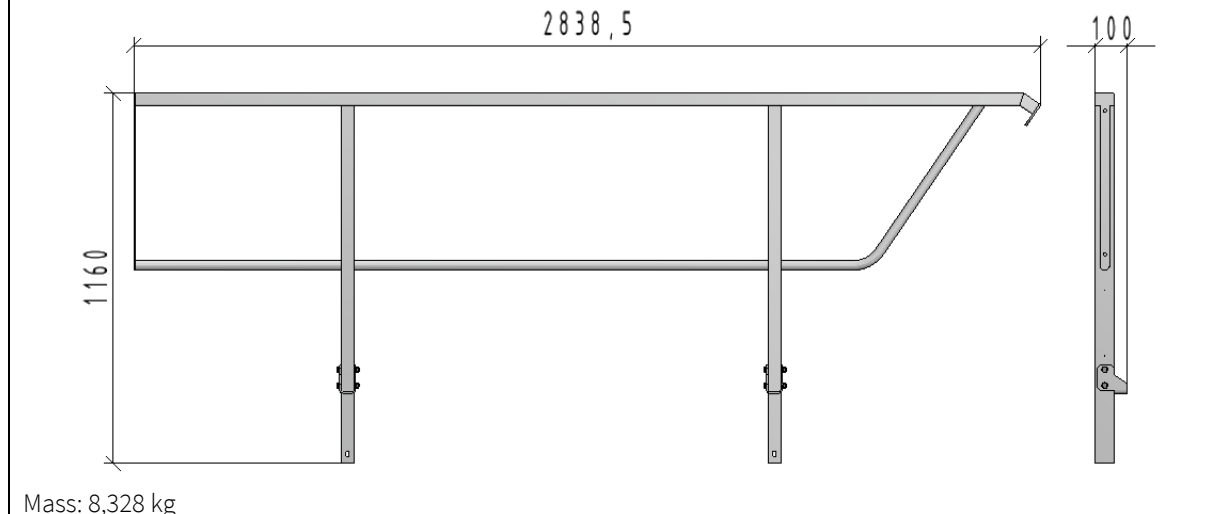

P-SK3-BS-GP

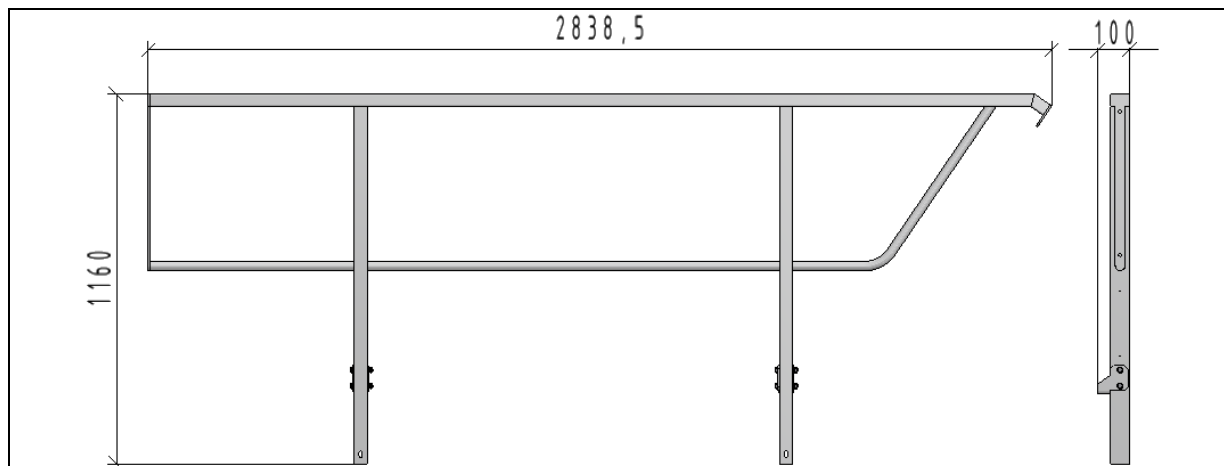

Mass: 8,328 kg

P-SK3-BS-P1

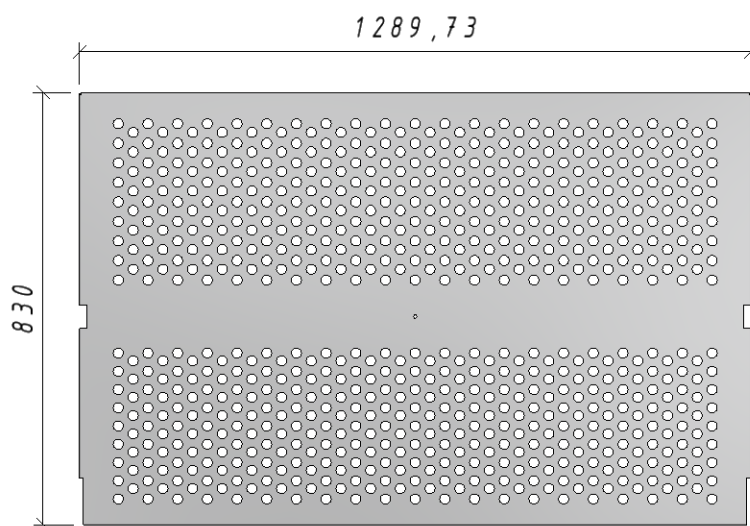

Mass: 3,833 kg

P-SK3-BS-P3

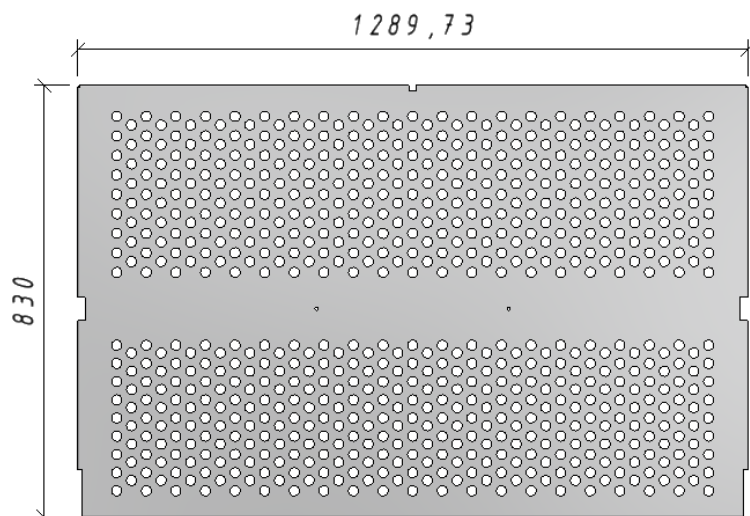

Mass: 3,830 kg

P-SK3-BS-P2L

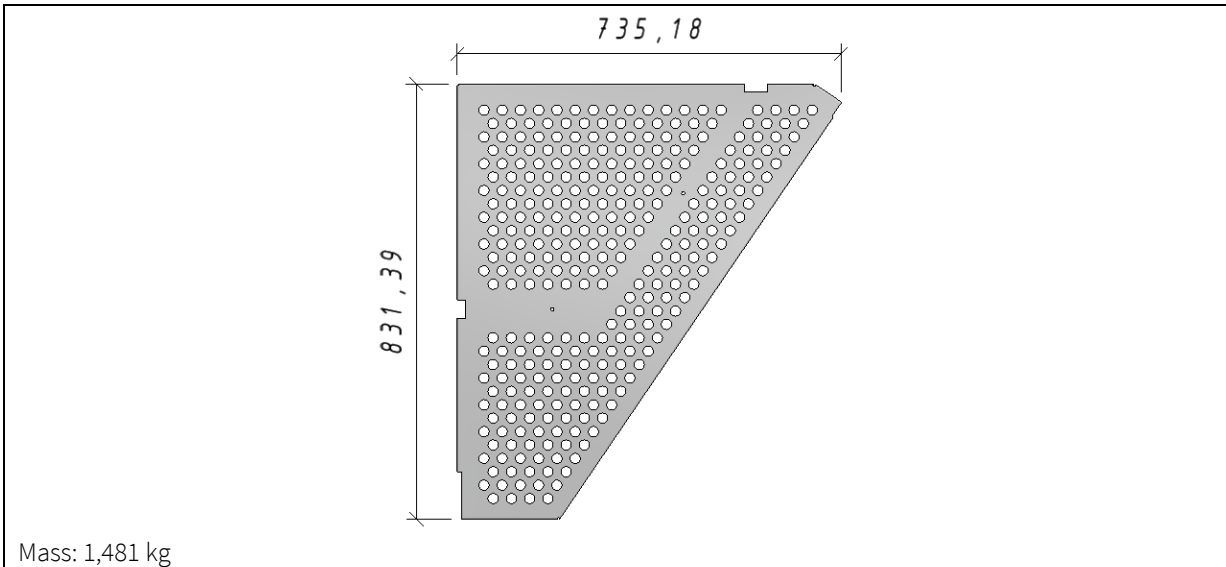

Mass: 1,481 kg

P-SK3-BS-P2P

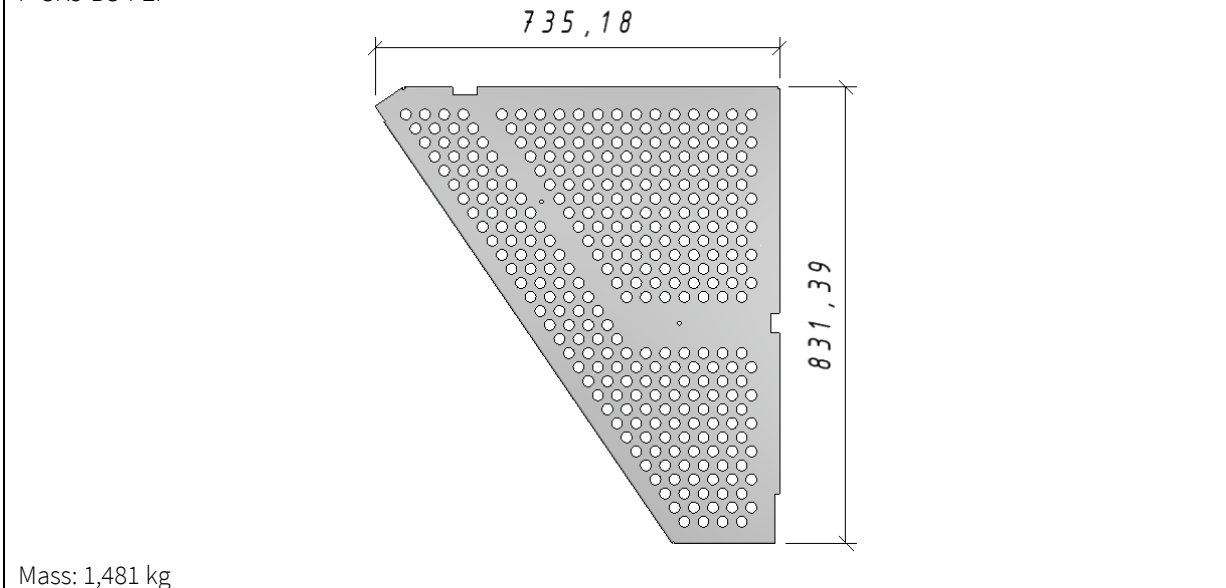

Mass: 1,481 kg

P-SK3-PR1

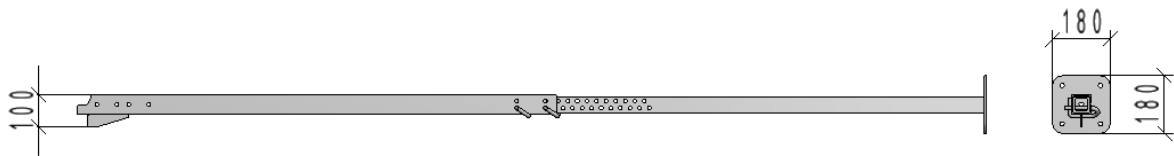

Mass: 9,446 kg

P-SK3-PR2

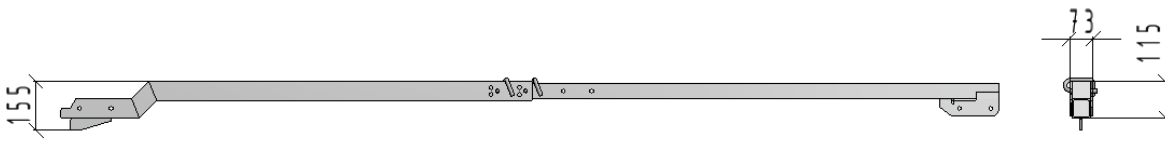

Mass: 9,532 kg

P-SK3-WT1.1	P-SK3-WT-1.25
-------------	---------------

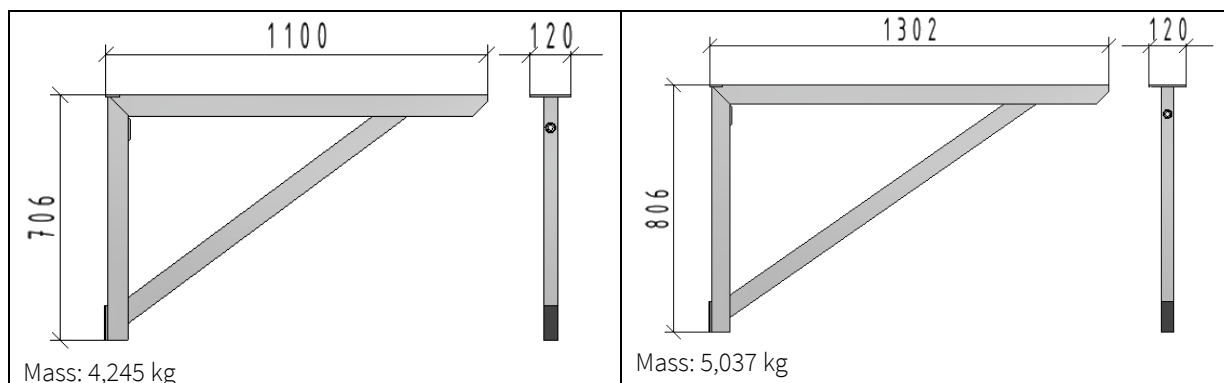

P-SK3-O1

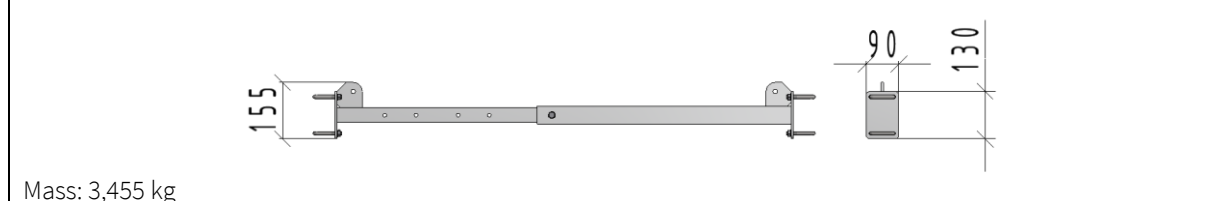

P-SK3-X1

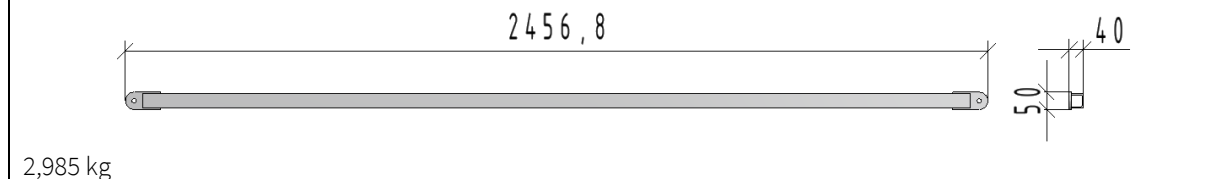

P-SK3-A1

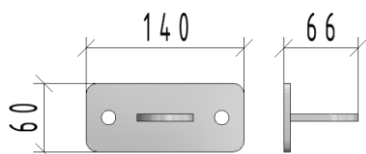

P-SK3-LP1

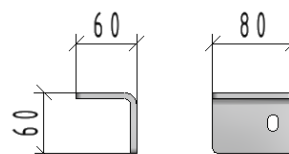

P-SK3-LP2

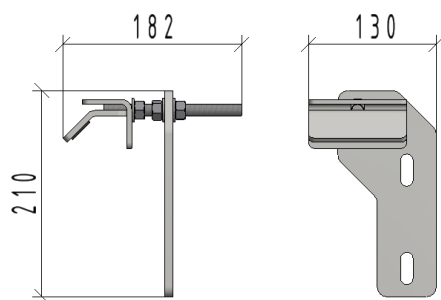

P-SK3-LP3

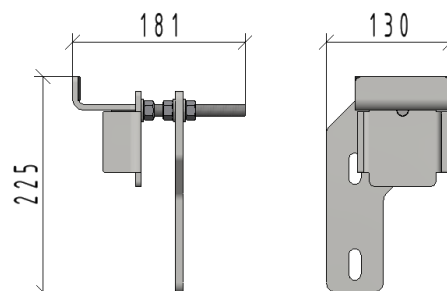

P-SK3-LP4

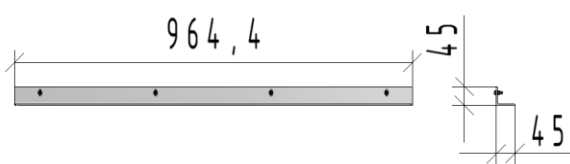

P-SK3-LP5

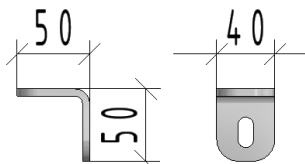



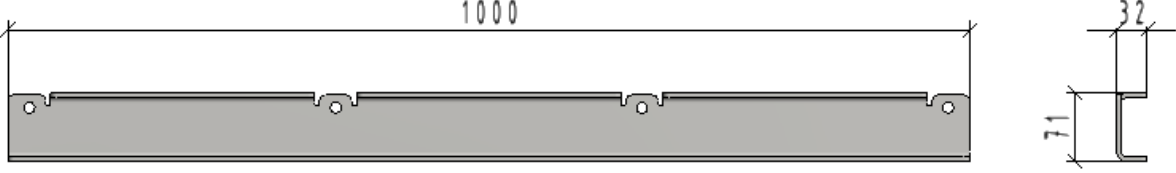
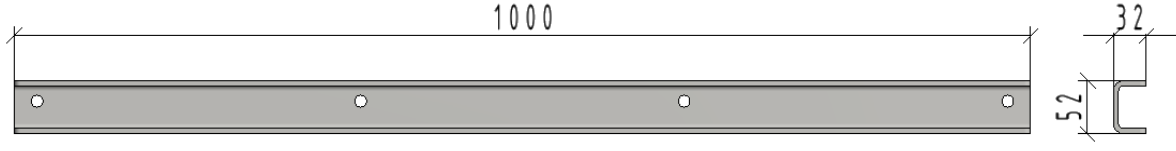
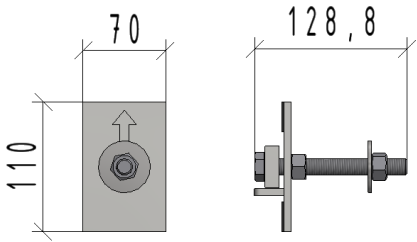
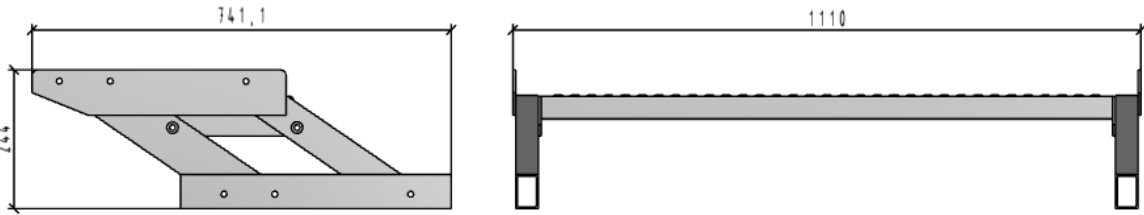
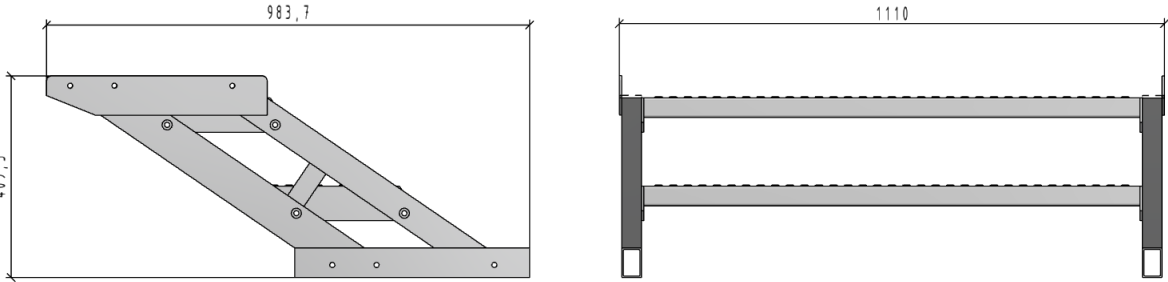

P-SK3-LP-SB1

 <p>1000</p> <p>71</p> <p>32</p> <p>4,440 kg</p>
<p>P-SK3-LP-SB2</p>  <p>1000</p> <p>52</p> <p>32</p> <p>Mass: 3,871 kg</p>
<p>P-SK3-ZW</p>  <p>70</p> <p>110</p> <p>128,8</p> <p>Mass: 0,874 kg</p>
<p>P-SK3-SB-FS1</p>  <p>741,1</p> <p>244</p> <p>1110</p> <p>Mass: 13,400 kg</p>
<p>P-SK3-SB-FS2</p>  <p>983,7</p> <p>409,5</p> <p>1110</p> <p>Mass: 3,087 kg</p>

3. Tools necessary for installation of container stairs

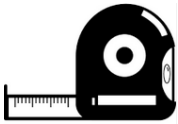
Table 2. List of tools

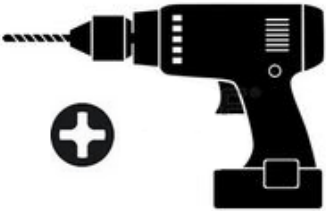
	<p>Spanners: 21,19,17,13,10</p>
	<p>Level</p>
	<p>Measuring tape</p>
	<p>Joist, min. load capacity 1t</p>
	<p>Wkrętarka z bitem krzyżowym</p>

4. Assembly operations with individual elements of the aluminum container stairs system.

The assembly instructions present the method of installation of the individual elements of the container stairs system.

4.1. Assembly: supports

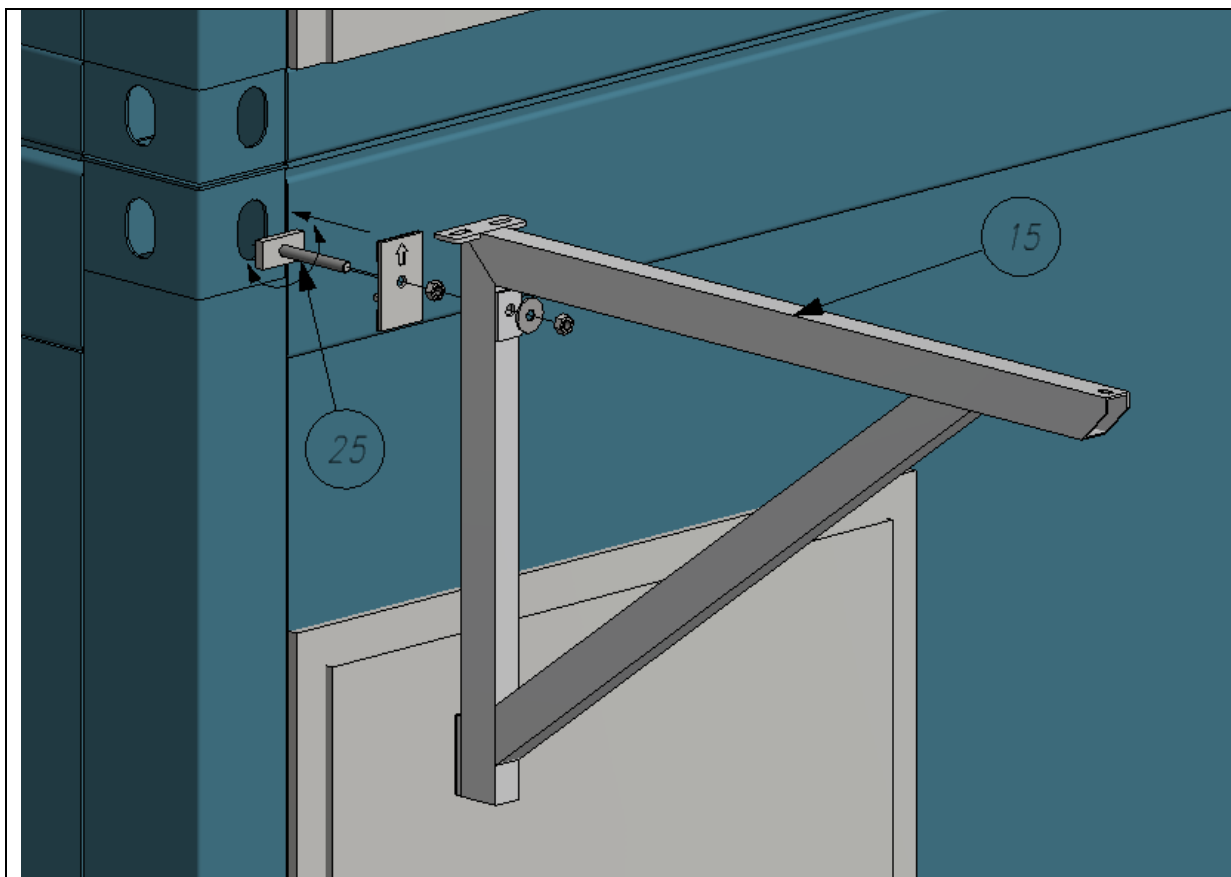

Zacisk wspornika należy ustawić strzałką do góry.

4.2. Assembly of landings

The landings are installed on supports.

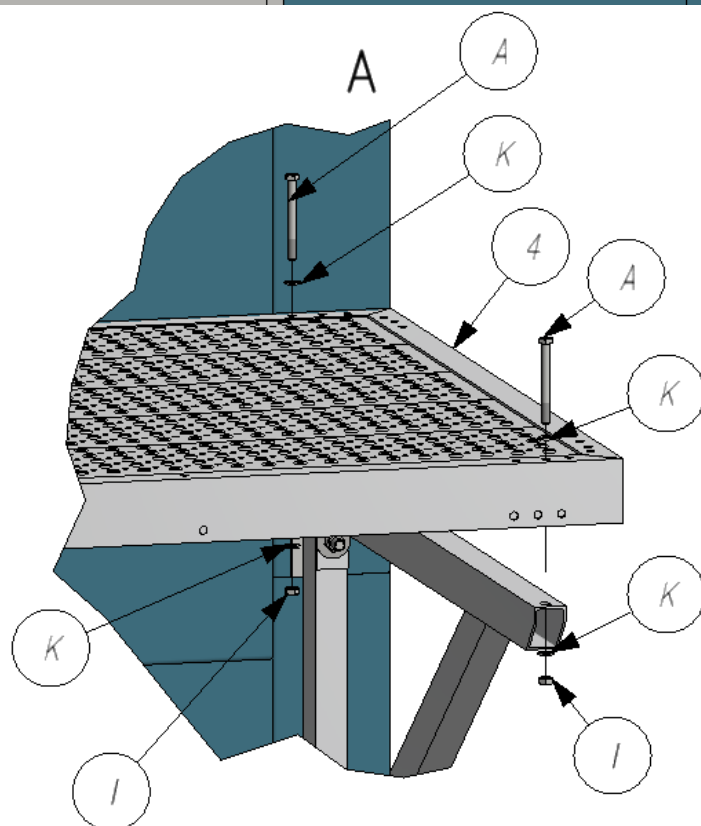
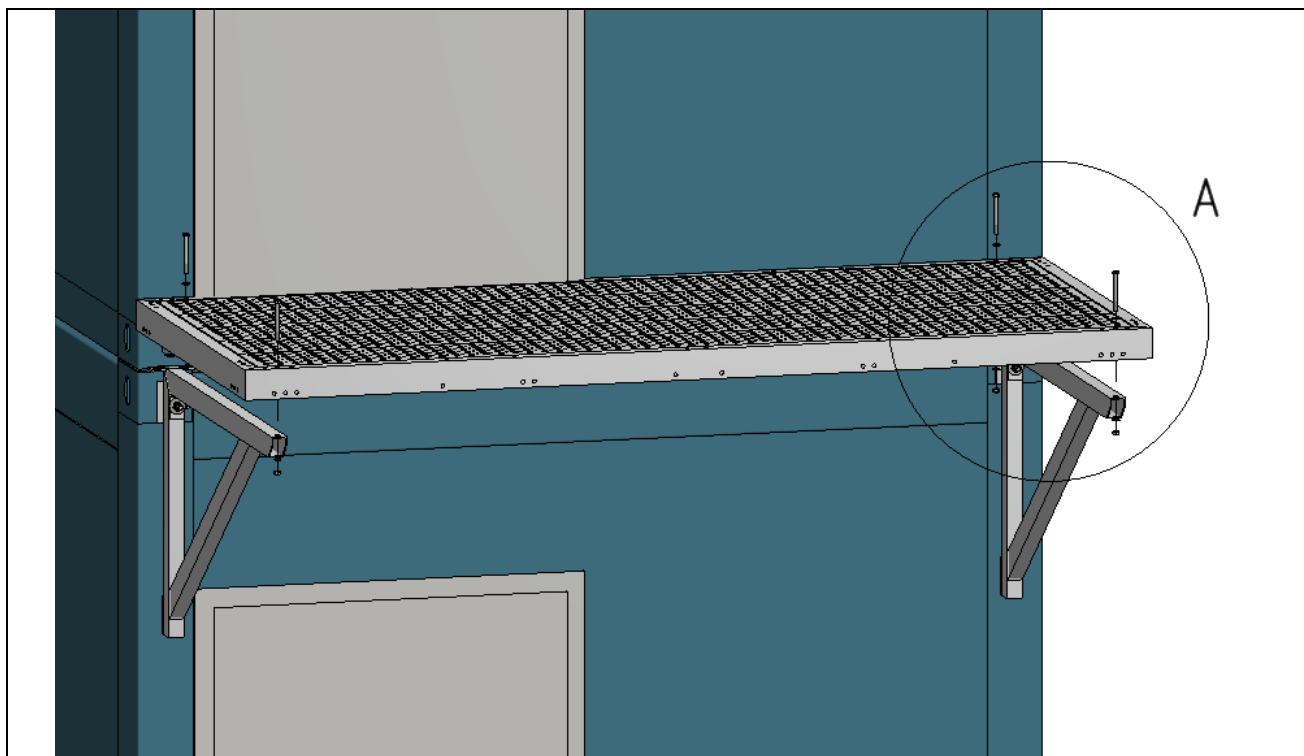

Podesty montowane na słupach Landings assemble on posts

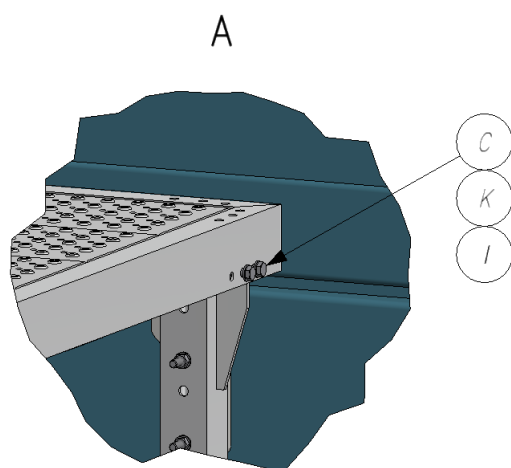
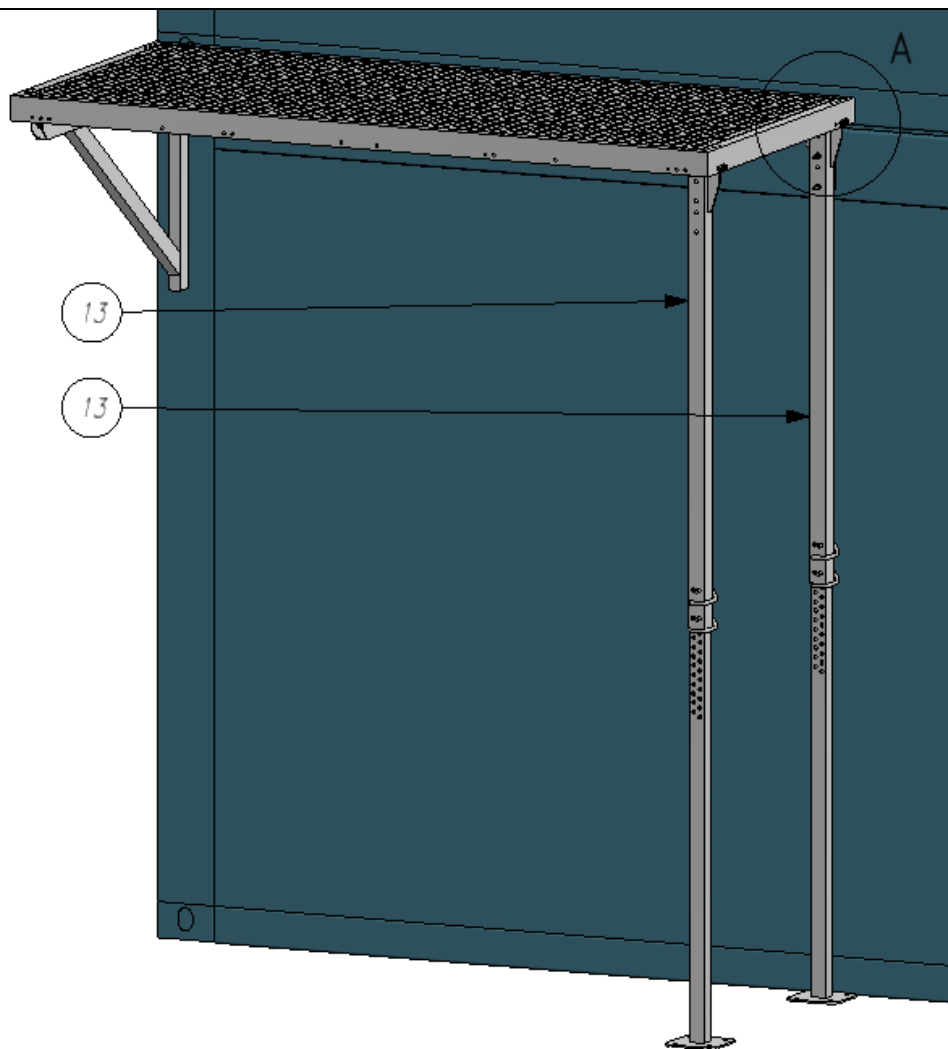

Śruby użyte do przykręcenia słupów służą również do montażu schodów (patrz strona 36) the Bolts used for screwing columns are also used for mounting stairs (see page 36)

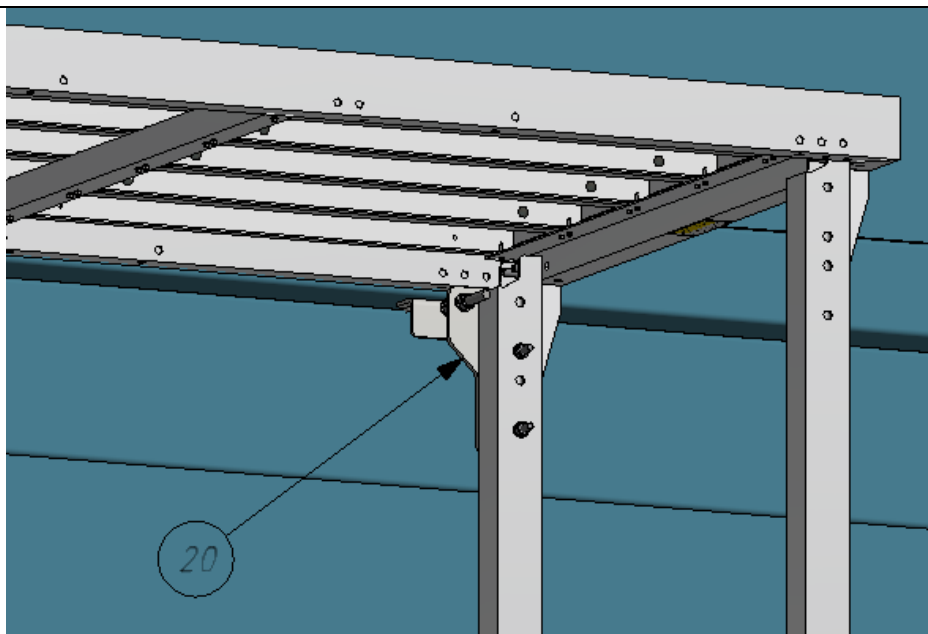

W przypadku montażu podestów na słupach należy użyć łącznika P-SK3-LP2/ P-SK3-LP3 w celu przykręcenia konstrukcji do kontenera (Montaż łączników strona 44). In case of assembling the landings on posts, the connector P-SK3-LP2/ P-SK3-LP3 should be used in order to screw the construction to the container. (Assembly : connectors, page 44)

Connecting the landings

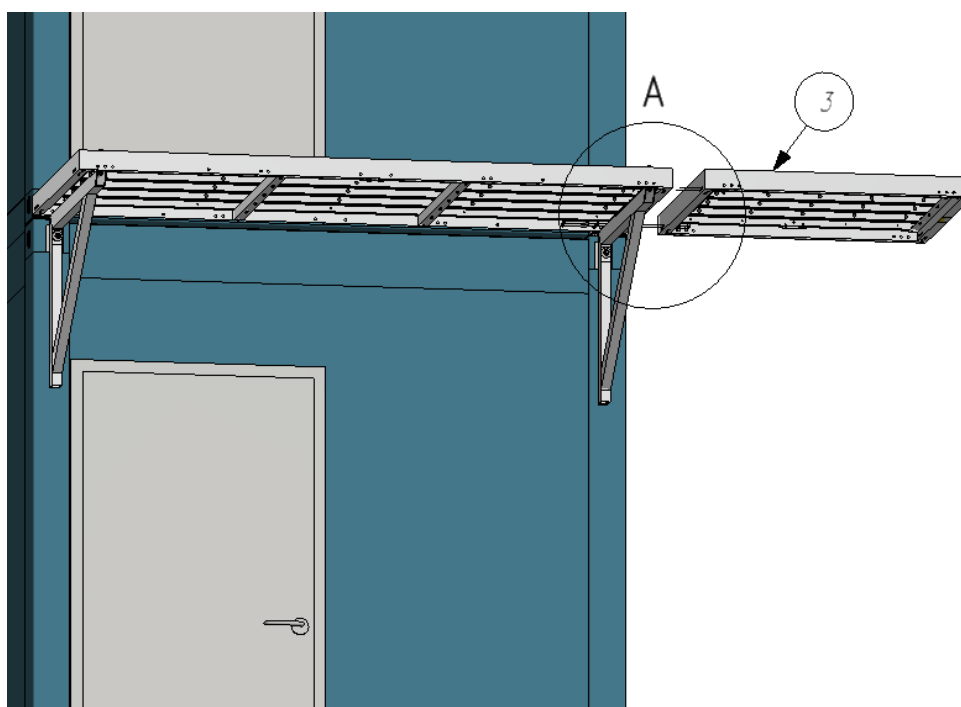

The landings should be connected with 4 bolts

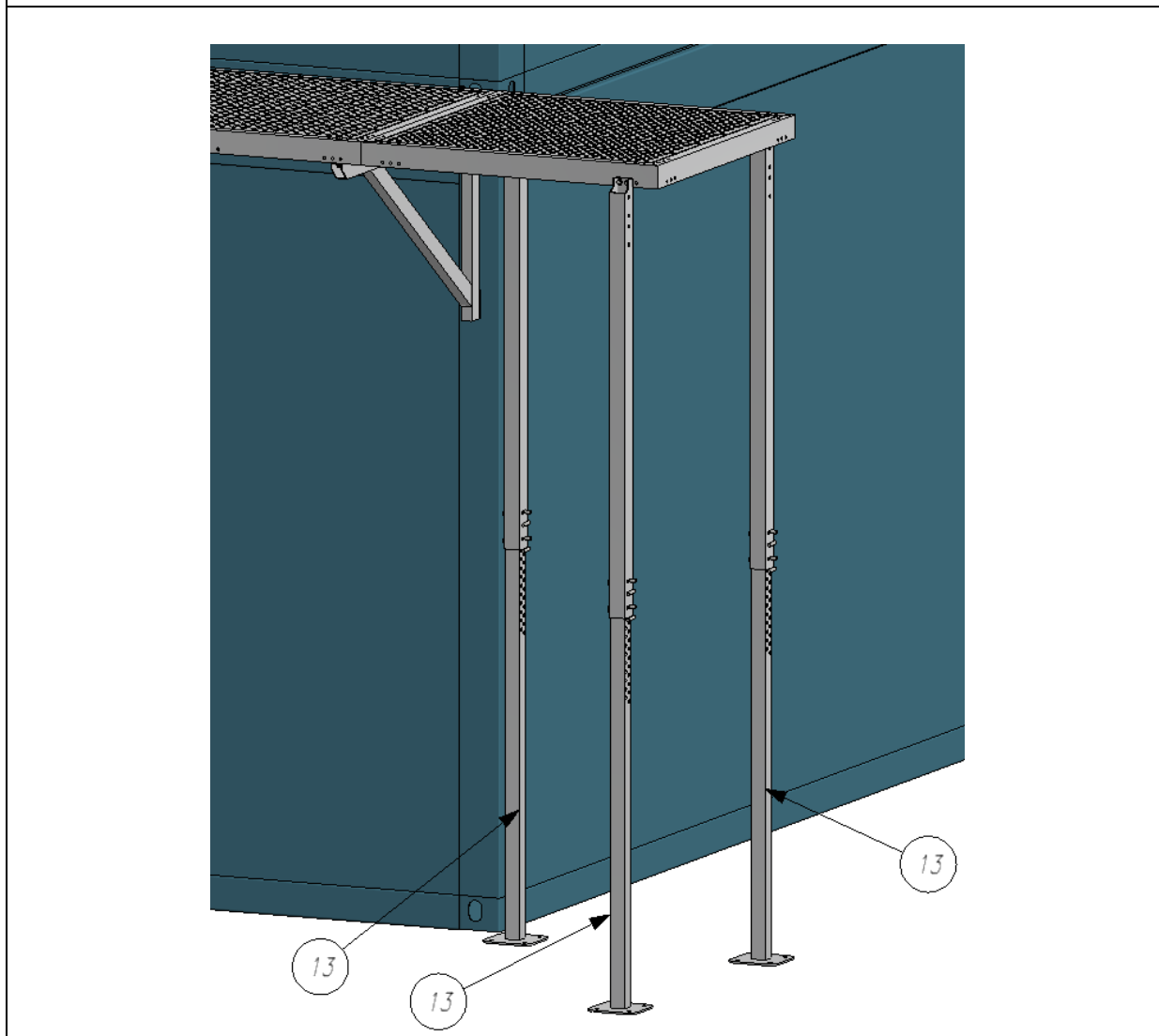
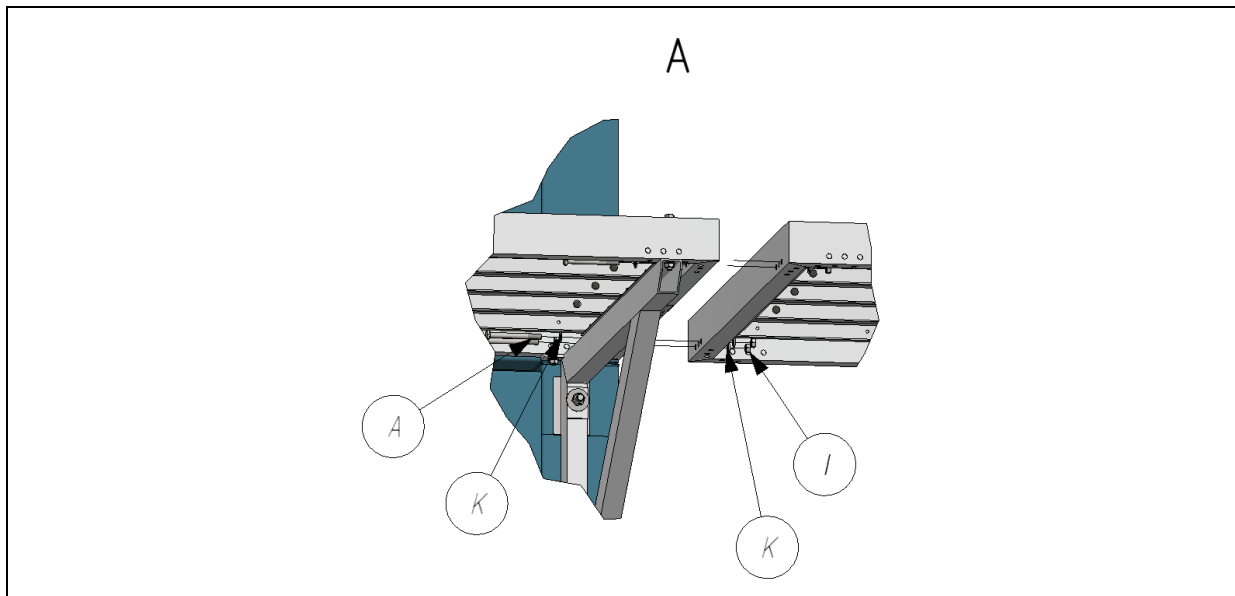

4.3. Assembly: posts

Śtopy należy podkładać pod podesty lub schodnie a następnie przykręcać zestawem śruba, podkładka,

nakrętka.

Posts should be located under the landings or stairs and then screwed on with bolt, washer, nut set.

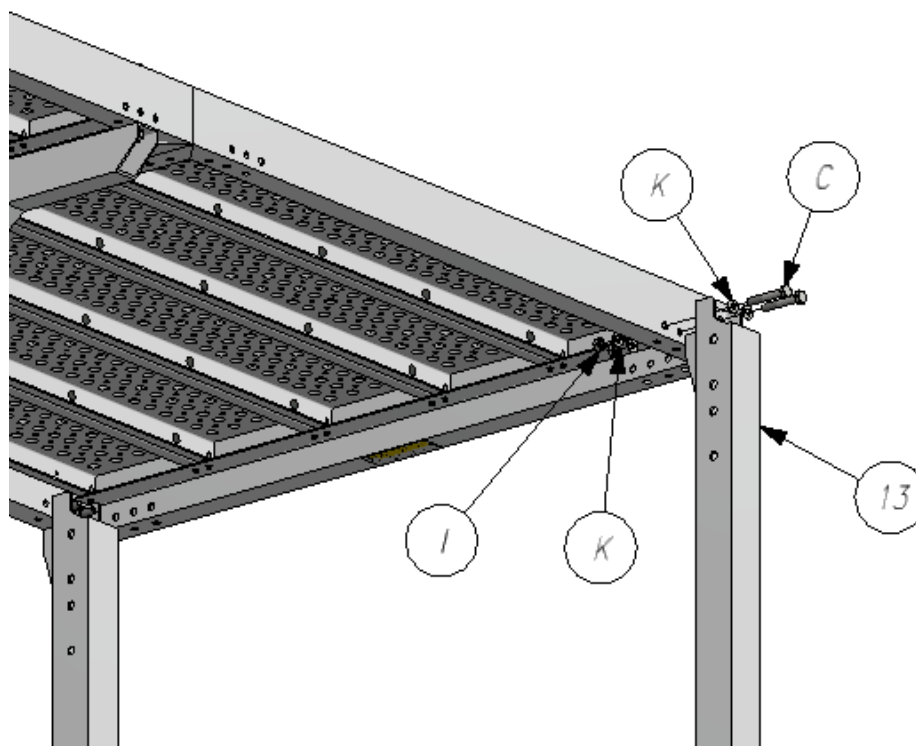
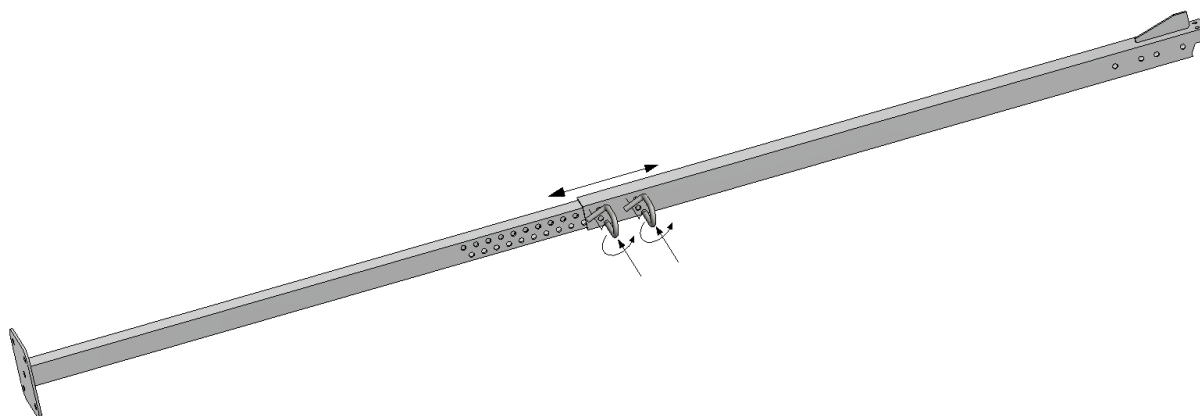

Słupy należy montować w ilości oraz lokalizacji odpowiednio do konfiguracji./ The posts should be installed in the number and location according to the configuration.

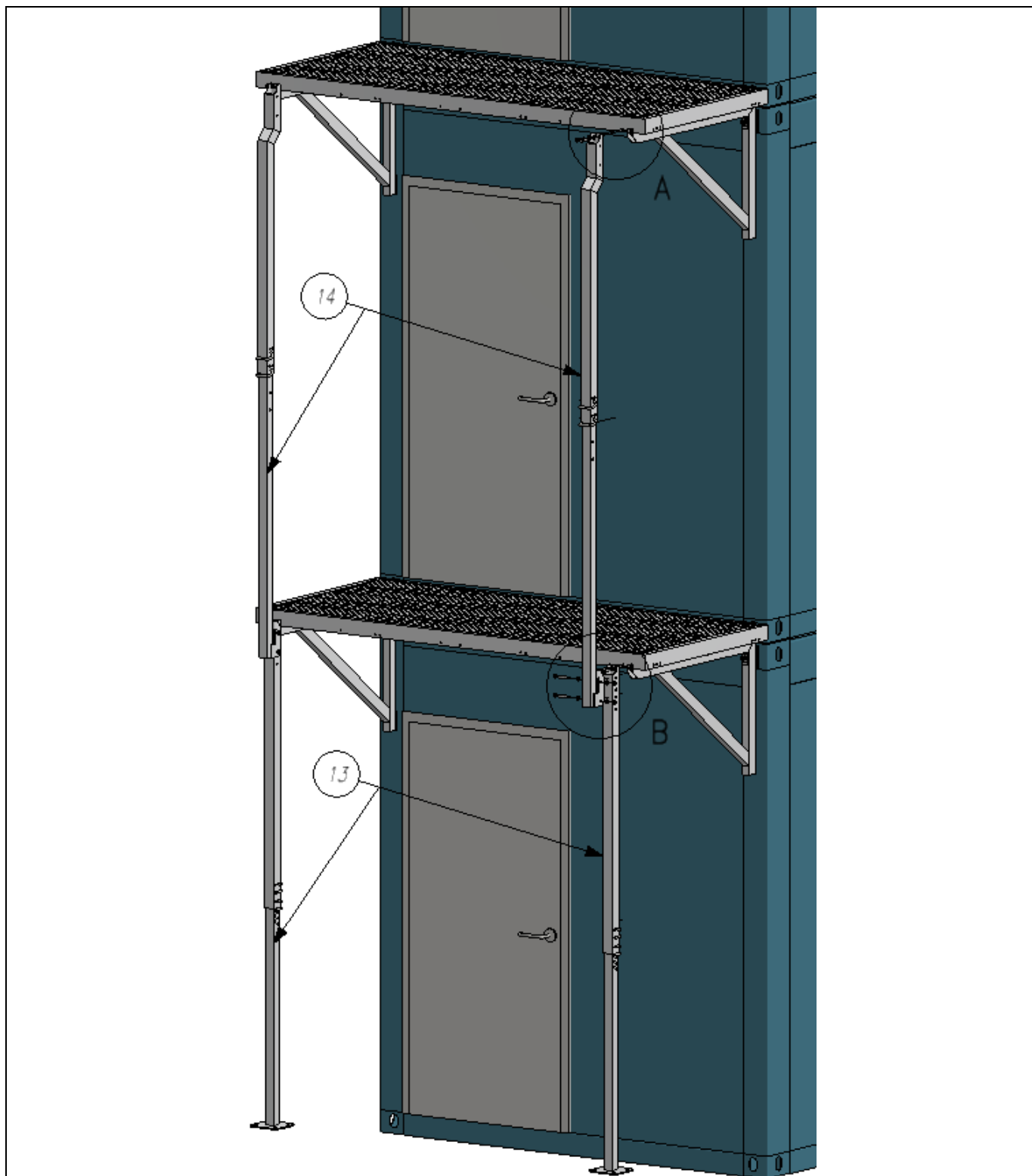

Podesty drugiej kondygnacji powinny być podparte od poziomu podstawy pierwszego kontenera./ The landings of the second level should be supported on the base level of the first container.

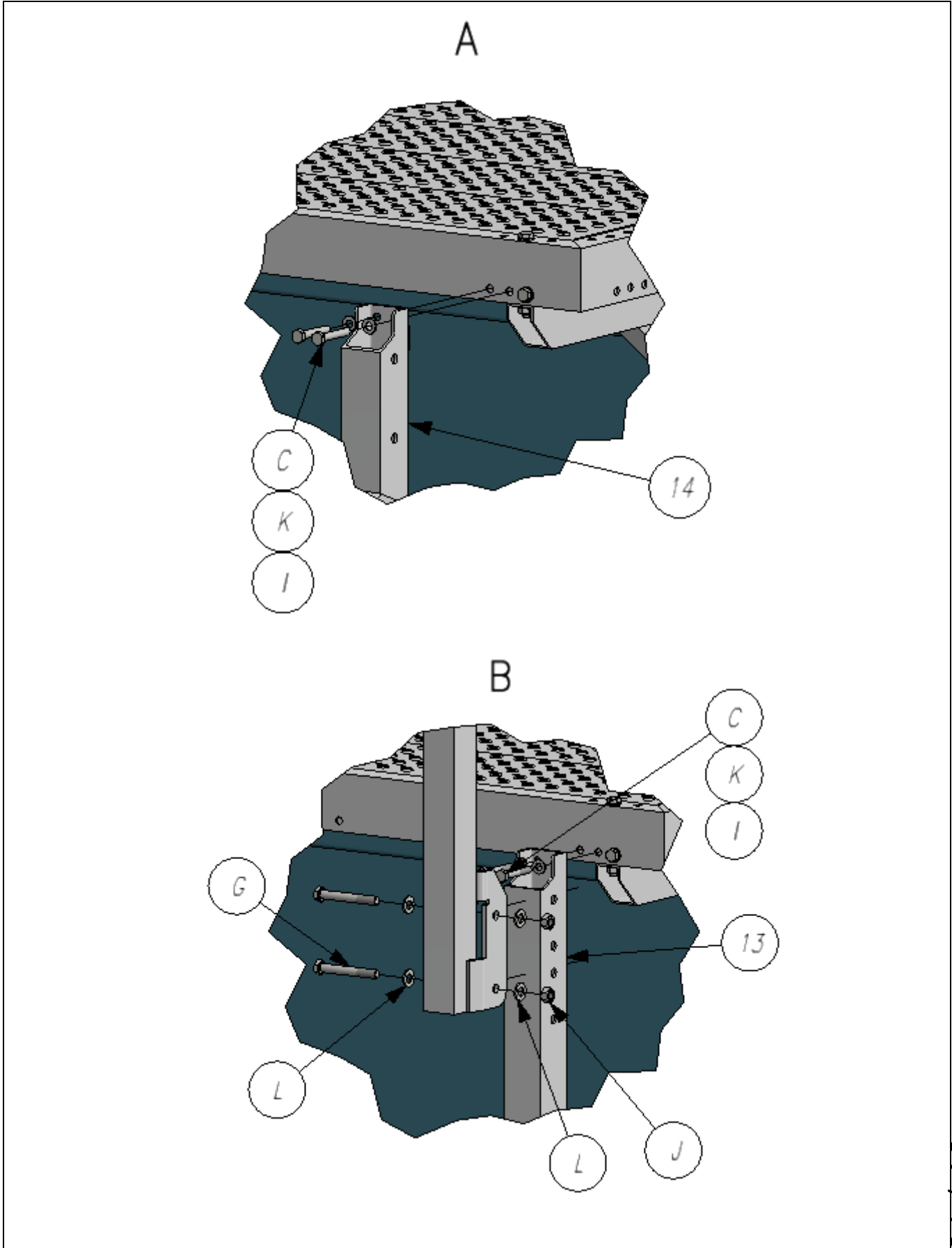

4.4. Assembly : stairs



W celu skręcenia schodni należy zdemontować dwa stopnie górne w przypadku schodni dolnej oraz dwa stopnie dolne w przypadku schodni górnej. Łączniki P-SK3-LP-SB1 oraz łączniki P-SK3-LP-SB2 przykręcane są tymi samymi śrubami co stopnie.

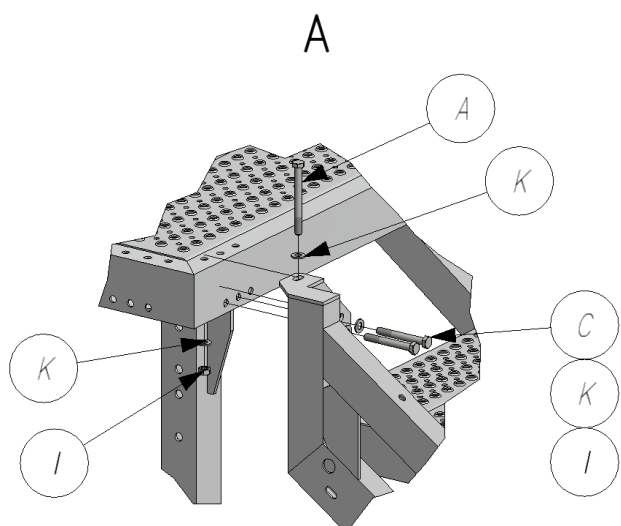
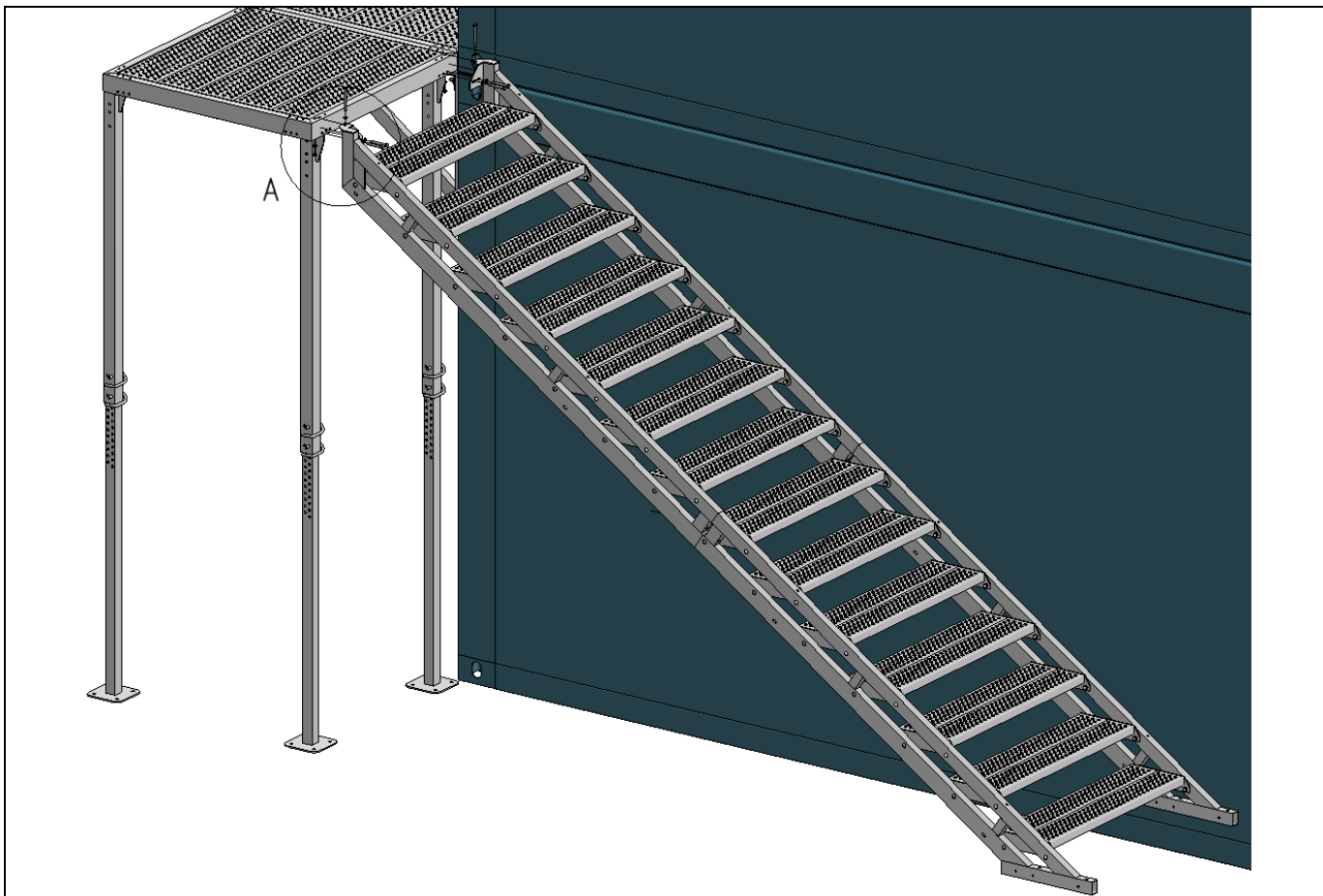

Słupy montowane przy schodniach powinny być przykręcane od wewnętrznej strony podestu tymi samymi śrubami co schodnia. The posts, which are installed next to the stairs should be screwed to the inner side of the platform with the same screws as the stairs.

4.5. Montaż przedłużeń schodów Assembly: extension stairs.

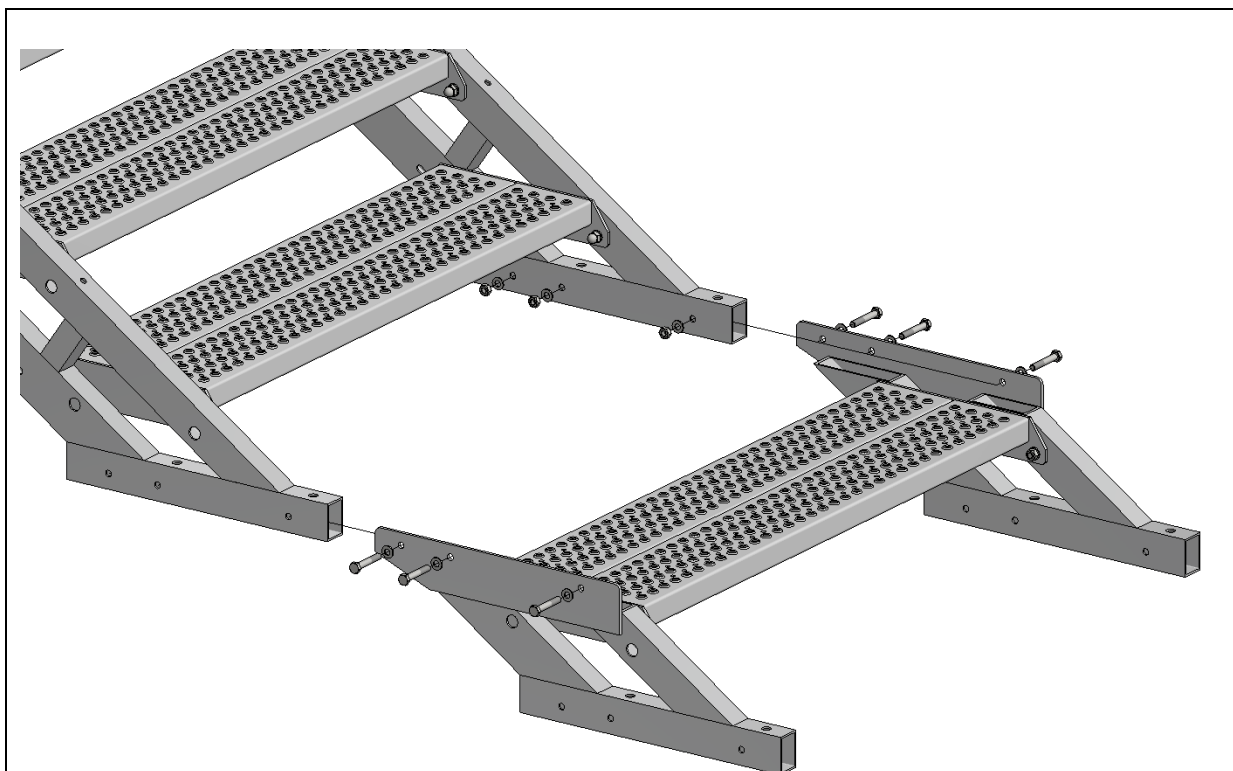

Przedłużki schodów są montowane zależności od wysokości kontenera przy pomocy zestawu śrub do nich załączonych.

4.6. Assembly: barriers



Poniżej przedstawiono sposób montażu barierki przemysłowych, barierki bezpieczne montować analogicznie. The heavy-duty barriers assembly method is shown below. The safe barriers should be installed in the same way.

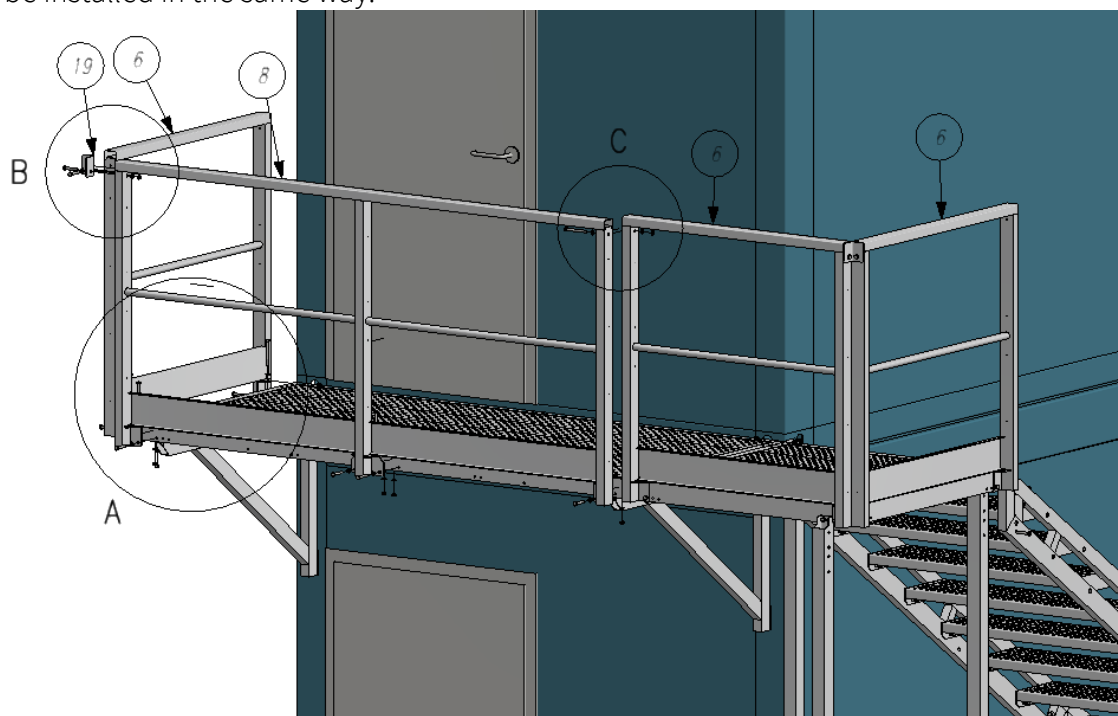

A

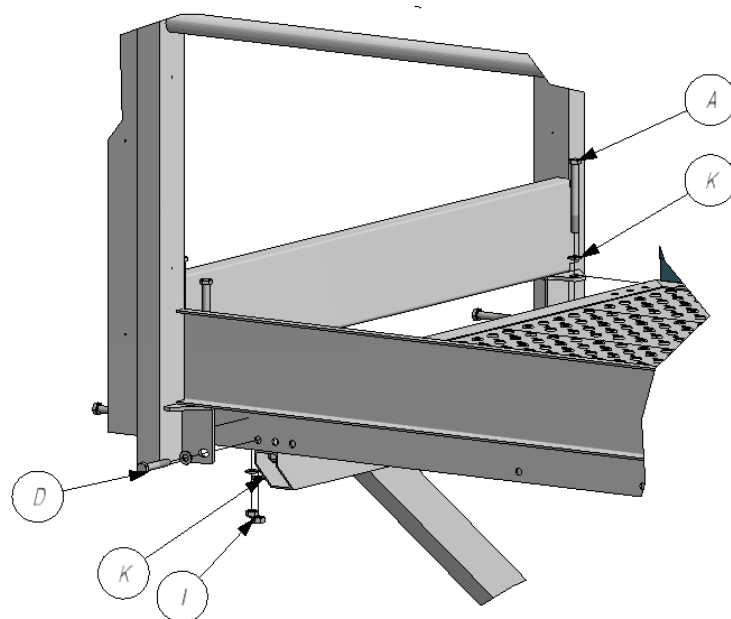

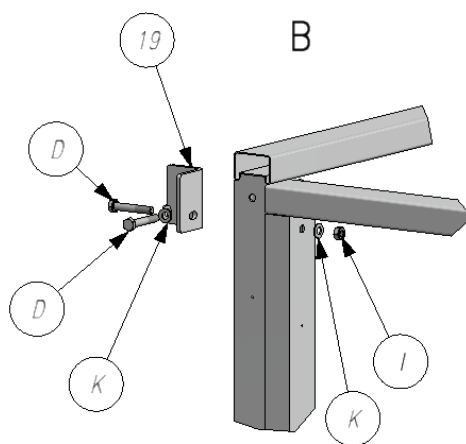

Barierki schodzące się prostopadle należy łączyć łącznikiem P-SK3-LP1.
Barriers going down in parallel should be connected with the connector P-SK3-LP1.

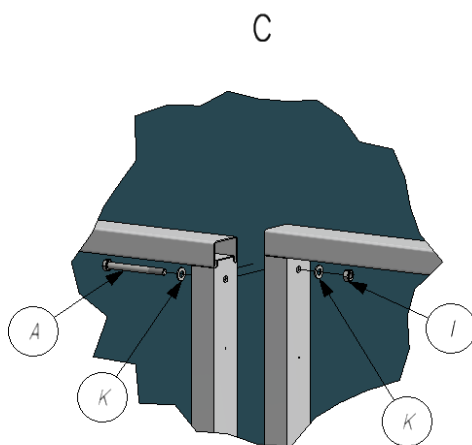

Barierki schodzące się równolegle należy skręcać między sobą. Barriers going down in parallel should be screwed with each other.

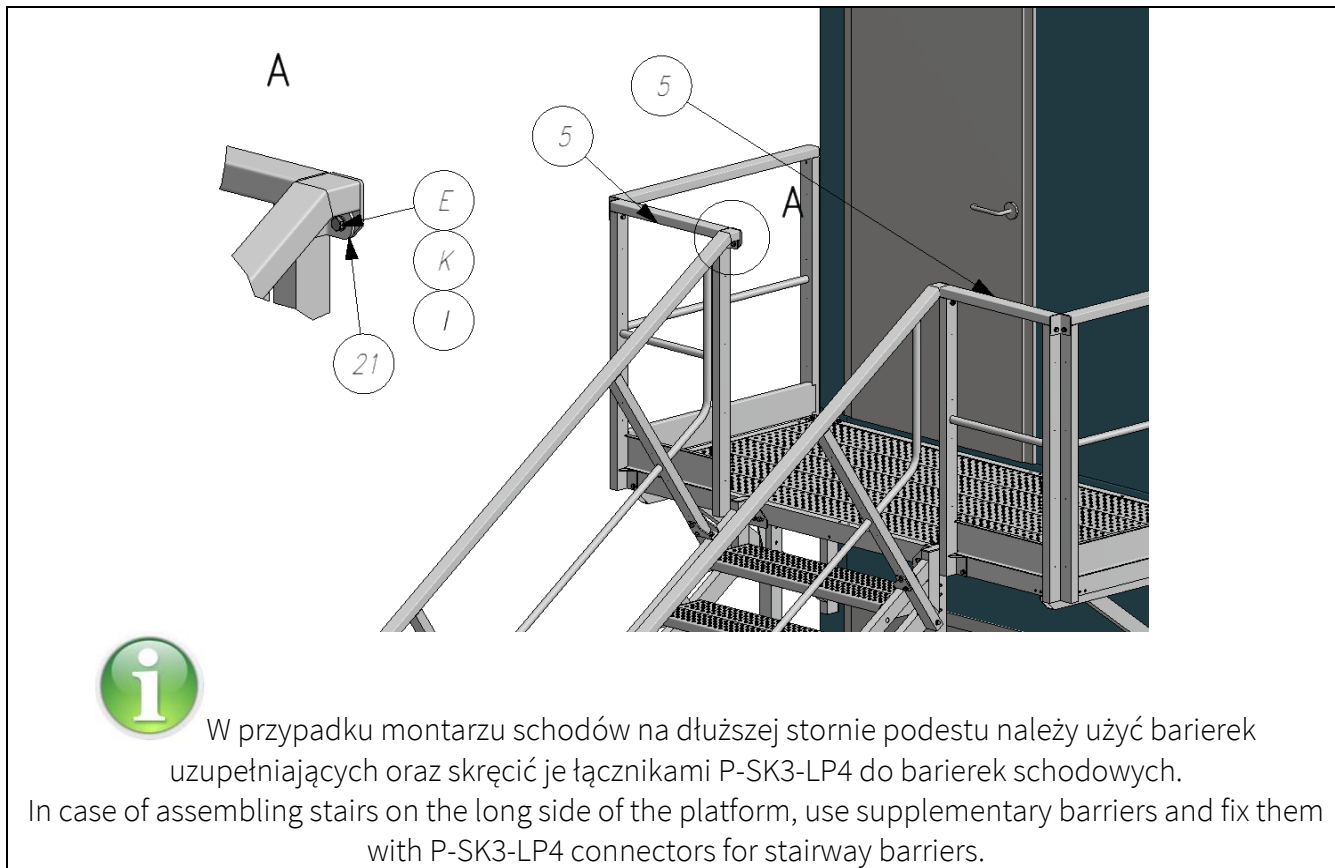

W przypadku montażu schodów na dłuższej stornie podestu należy użyć barierek uzupełniających oraz skręcić je łącznikami P-SK3-LP4 do barierek schodowych.
 In case of assembling stairs on the long side of the platform, use supplementary barriers and fix them with P-SK3-LP4 connectors for stairway barriers.

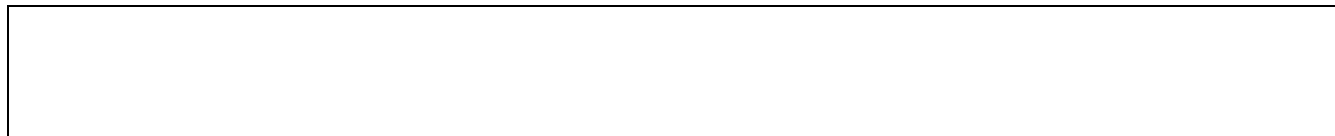

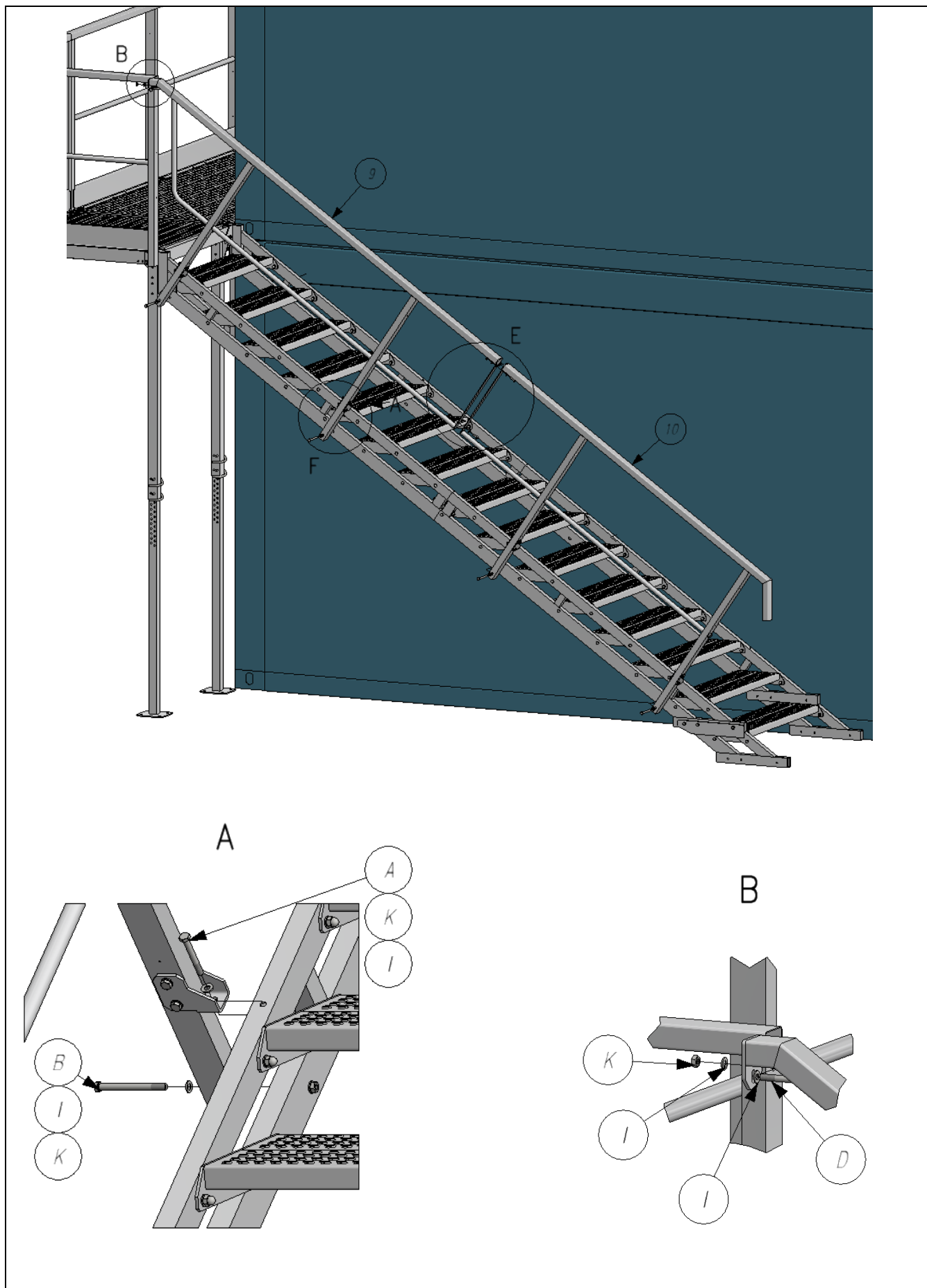

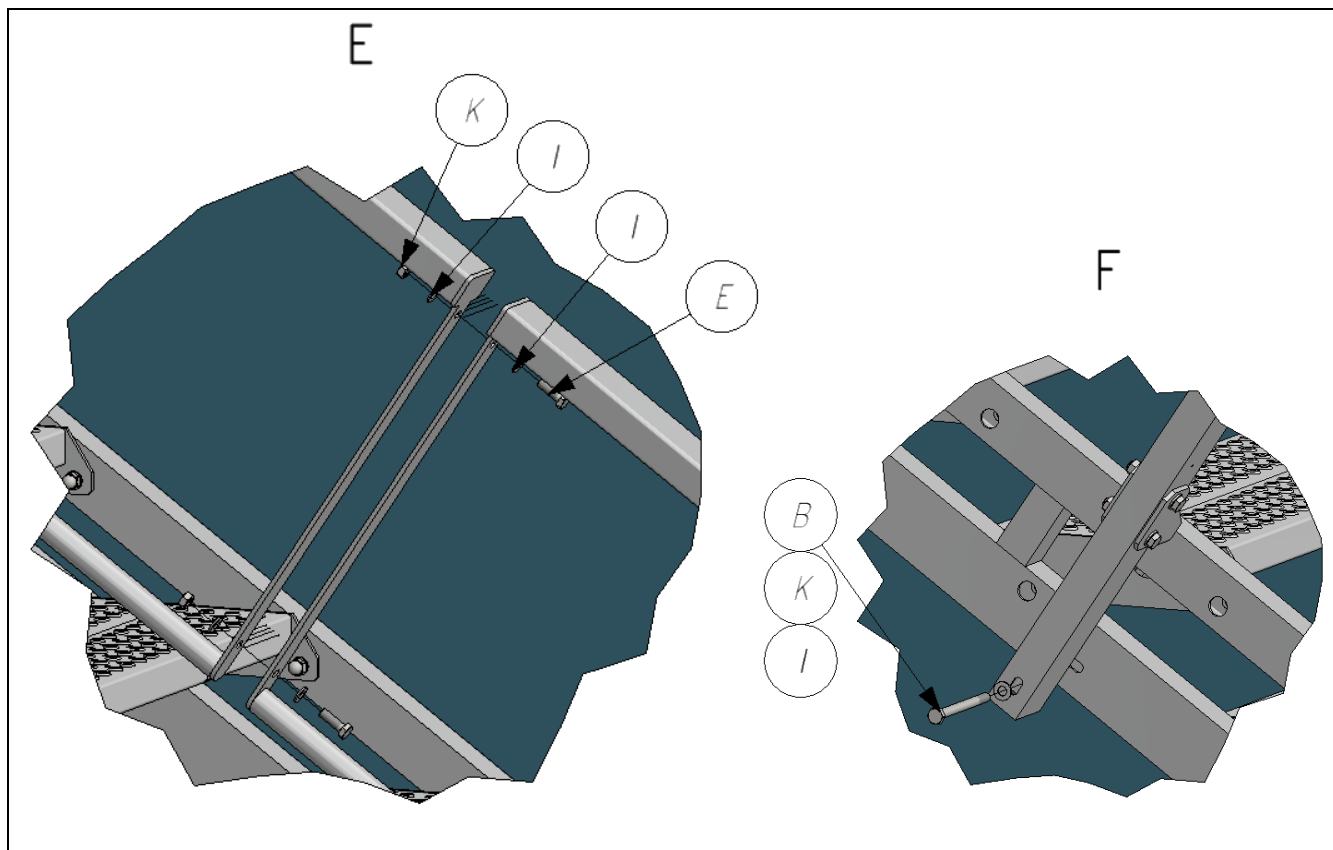

4.7. Assembly: Connector P-SK3-LP2

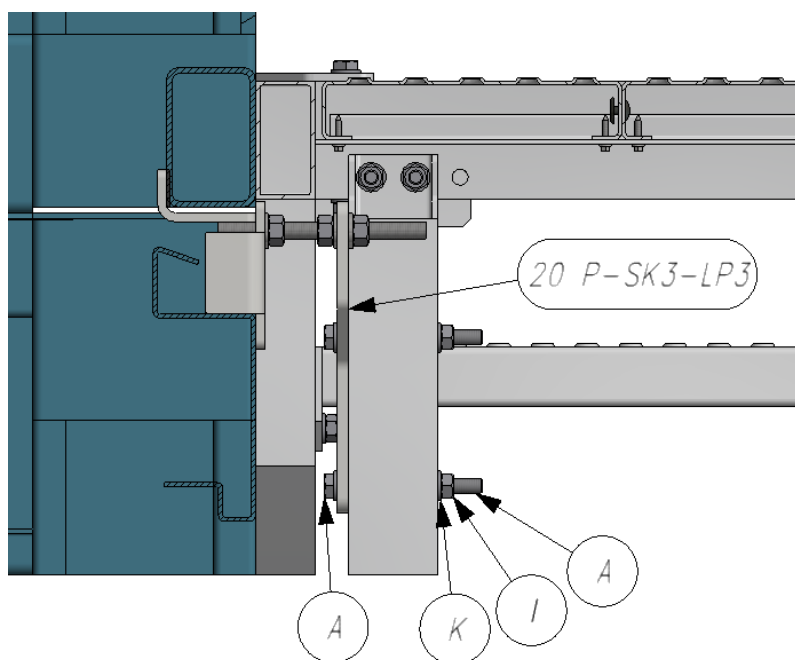
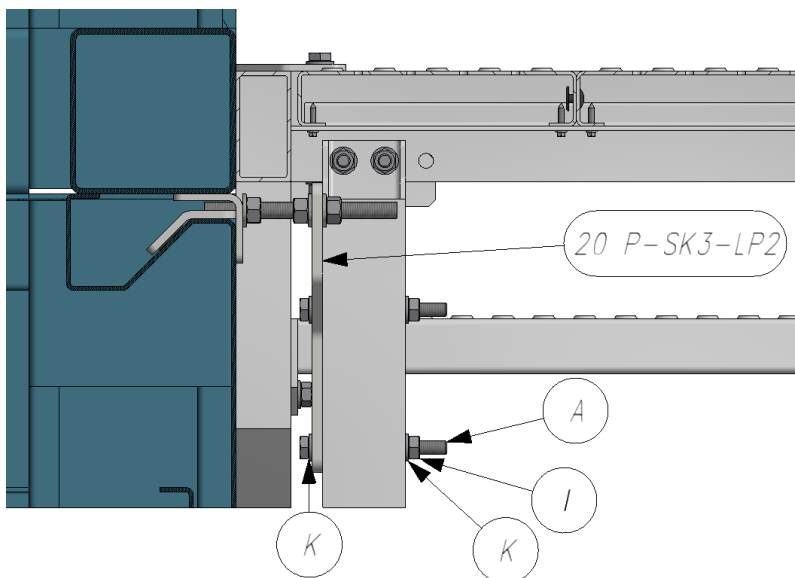

W zależności od konstrukcji ramy kontenera należy użyć łącznika P-SK3-LP2 lub P-SK3-LP3/ Depending on the construction of the container frame, use the P-SK3-LP2 or P-SK3-LP3 connector

4.8. Assembly: safe barriers



Montaż barierek bezpiecznych odbywa się poprzez przykręcenie wypełnienia w postaci paneli z blachy perforowanej do barierek przemysłowych przy pomocy wkrętów. W celu ułatwienia montażu w barierkach zostały przygotowane wstępne otwory w które należy wkręcić wkręty./ The assembly of safe barriers takes place by screwing the filling in the form of perforated sheet panels for industrial barriers with the use of screws. In order to facilitate assembly in the barriers, preliminary holes have been prepared, in which screws should be screwed.

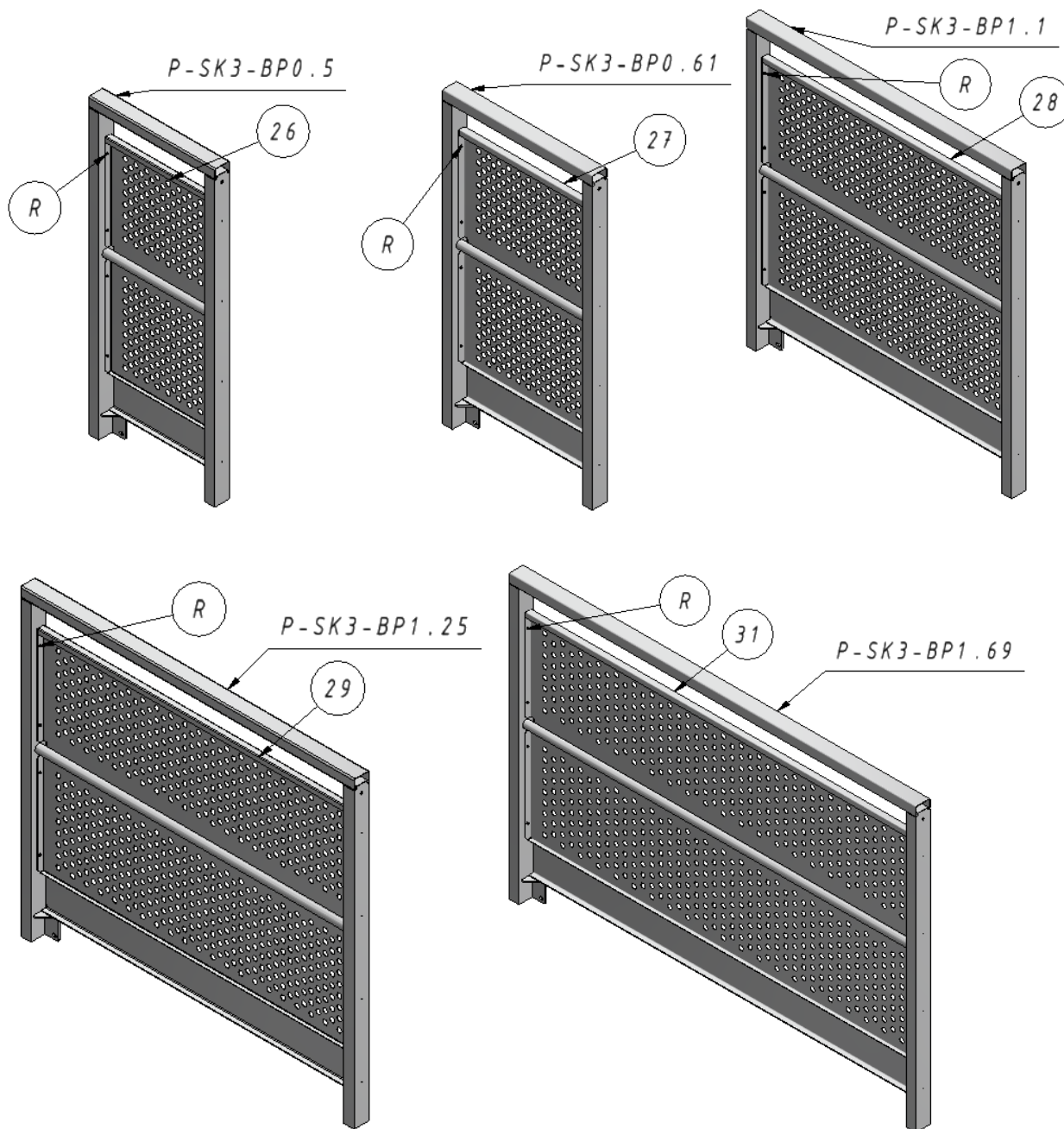

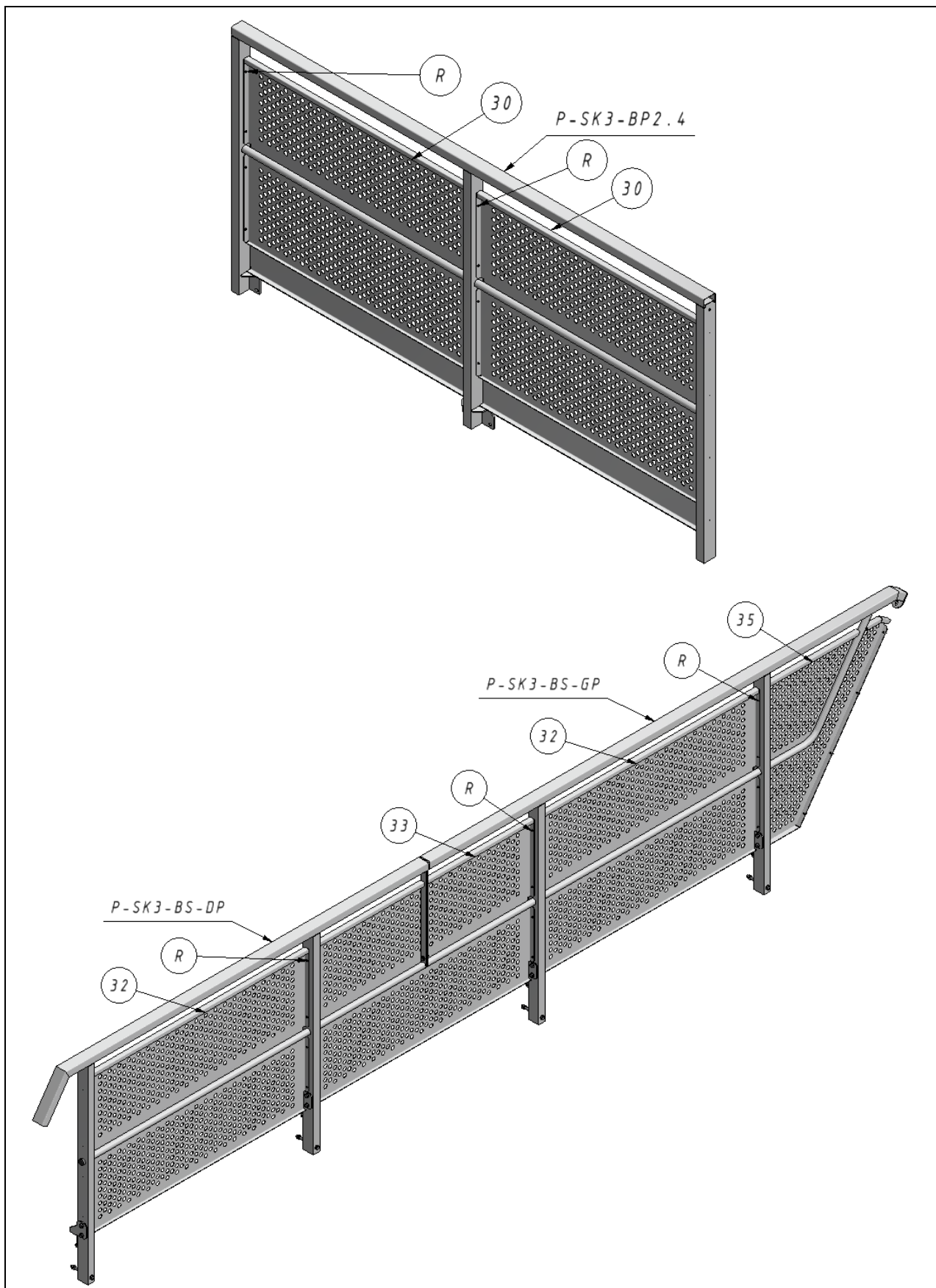

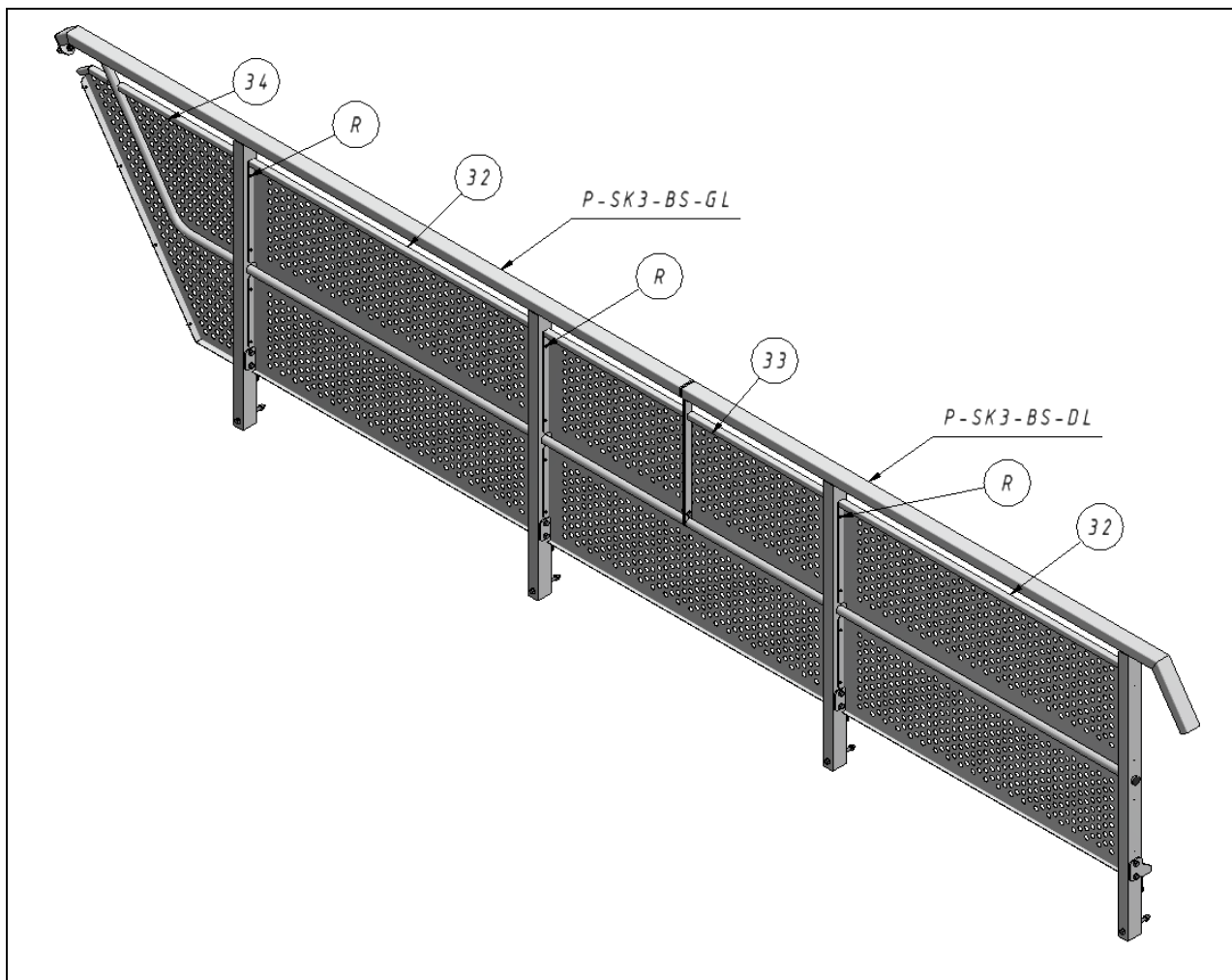

4.9. Assembly: connector P-SK3-LP5

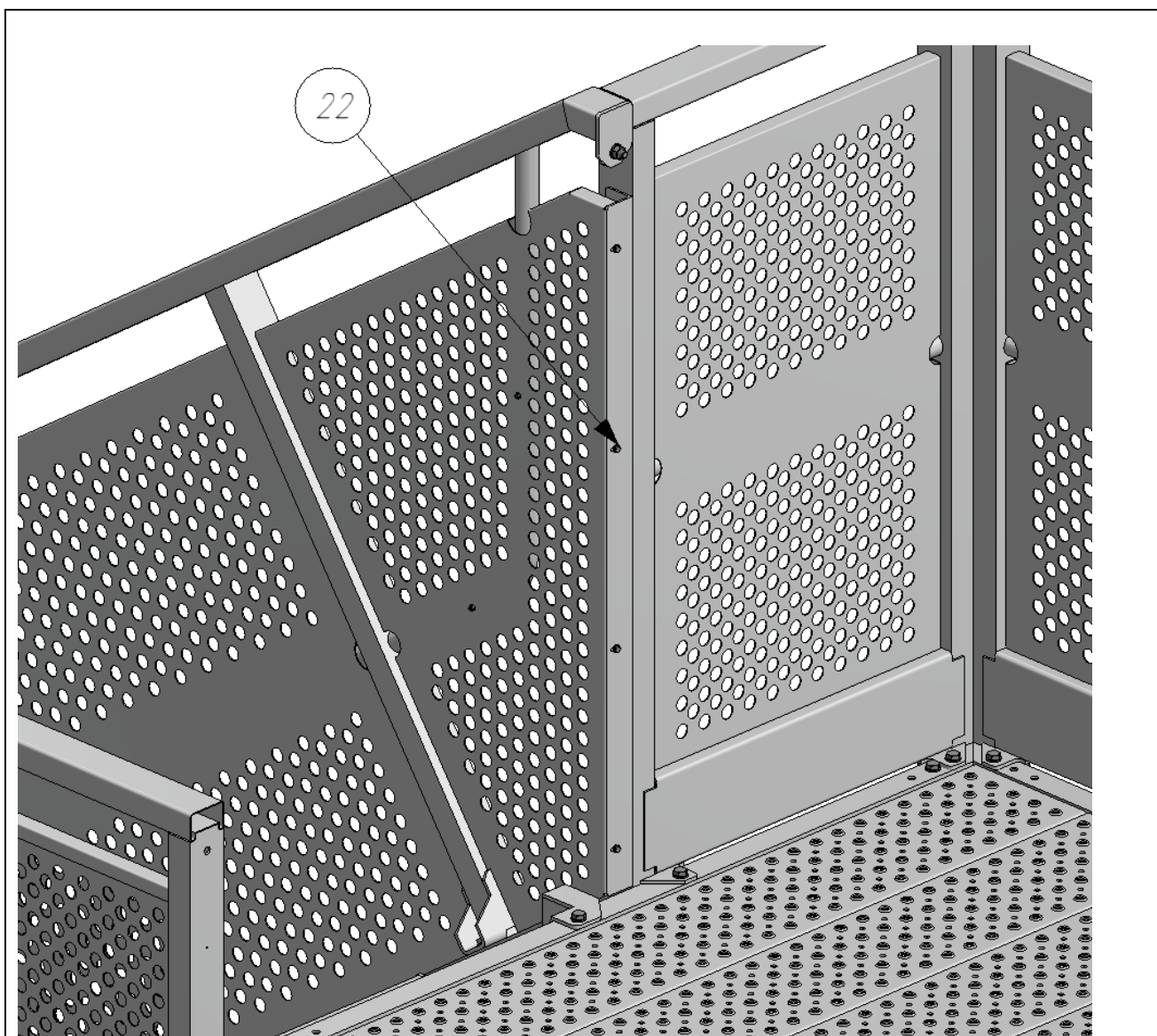

Łącznik P-SK3-LP5 służy do połączenia paneli barierki bezpiecznych kiedy schody montowane są prostopadłe do długiego podestu. Łącznik należy przykręcić do barierki podestu wkrętami znajdującymi się w zestawie barierki schodowej górnej, następnie śrubami znajdującymi się w zestawie łącznika przykręcić panel barierki schodowej górnej.

P-SK3-LP5 connector is used to connect safe barrier panels when the stairs are assembled perpendicularly to a long landing. The connector should be screwed to the landing barrier using the screw set from the upper stairs barrier, then, using screws from the connector set, screw the upper stairs barrier panel.

4.10. Montaż stężenia słupów. Assembly:

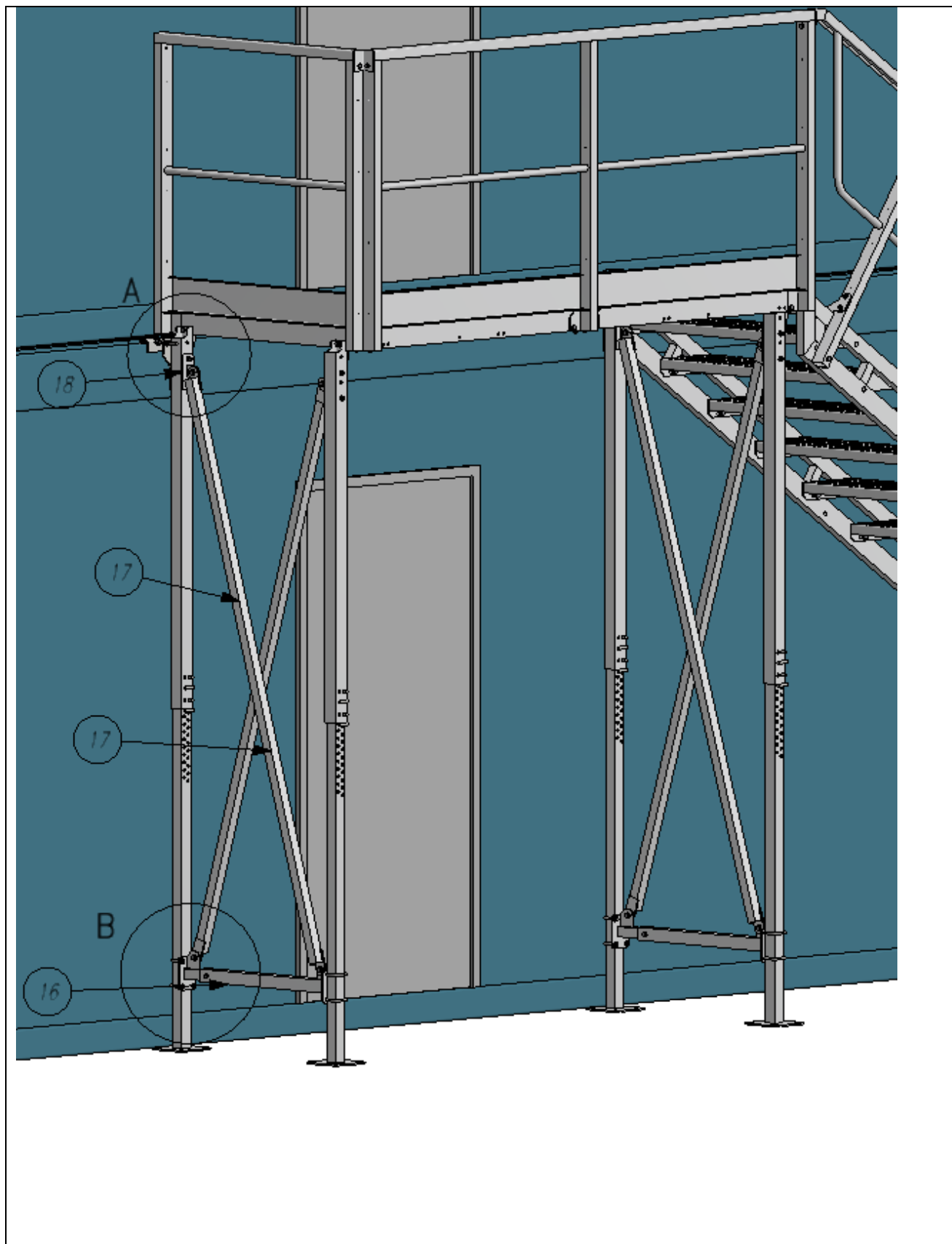

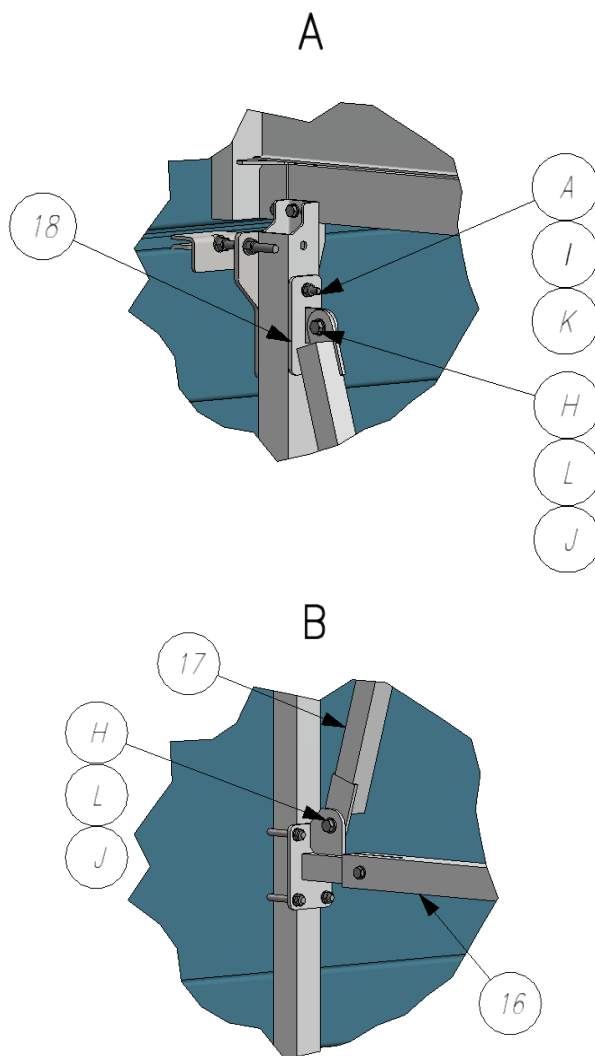

Poprzeczka P-SK3-O1 posiada stopniową regulację długości pozwalającą na dopasowanie jej długości w zależności od szerokości montowanego systemu schodów.
 The bar P-SK3-O1 has a gradual length adjustment allowing its length to be adjusted depending on the width of the installed stair system.