

Appendix no. 1

Installation manual

Temporary Spiral Staircase SST



Piotr Abram

(Prepared by)

Robert Cieśla

(Verified by)

Miłosz Muzyka

(Approved by)

Issue 15 November 2023

## List of contents

1. Introduction .....	4
2. SST system components .....	5
3. Graphical list of SST system fasteners .....	10
4. List of components of the SST system .....	11
5. Staircase descent levels .....	13
6. List of tools necessary of the installation of the temporary spiral staircase .....	15
7. Installation operations for individual SST system components .....	16

## List of revisions

N o.	FULL NAME	DEPARTME NT	REVISION DATE	SCOPE OF CHANGES	COMMENT S
1	Paweł Oleszkowicz	BR	25 March 2022	Added heights of individual descent steps Updated installation of R8 railings	
2	Paweł Oleszkowicz	BR	18 October 2022	Updated section 6.3 with connection components	
3	Piotr Abram	BR	20 July 2023	Supplemented section 6.11 with end railings	
4	Piotr Abram	BR	23 November 2023	Added sections 6.16, 6.17	
5	Piotr Abram	BR	12 August 2024	Changed graphics on pages 19, 20	
6	Piotr Abram	BR	6 Septembe r 2024	Section 4, table 2 and 3.	
7					
8					
9					
10					
11					
12					
13					
14					
15					

## 1. Introduction

The installation instructions are included as an appendix to TLC's technical and operating documentation for the temporary spiral staircase system.

The temporary spiral staircase consists of components according to the specifications attached to the delivery. The system features bolted connections. The system is supplied in the form of separate components such as landings, railings, steps, connectors, stairs and columns. The components are assembled in a specific order.

The temporary spiral staircase, as modular design, may be configured as needed (in the scope defined by the manufacturer). The setting of the individual configurations should be in accordance with the DTR.



## 2. SST system components

The list of components in table 1 presents the components of the temporary spiral staircase system and their quantities installed depending on the configuration.

Tab 1. Temporary spiral staircase system components.

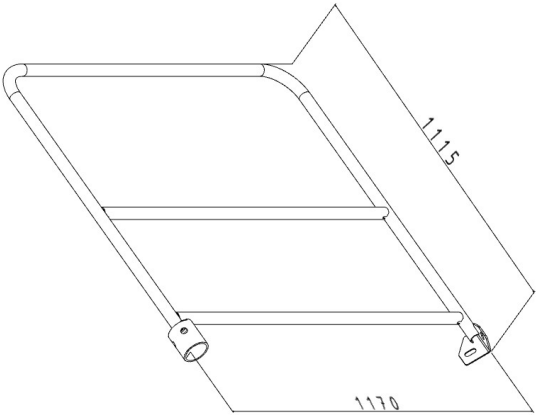
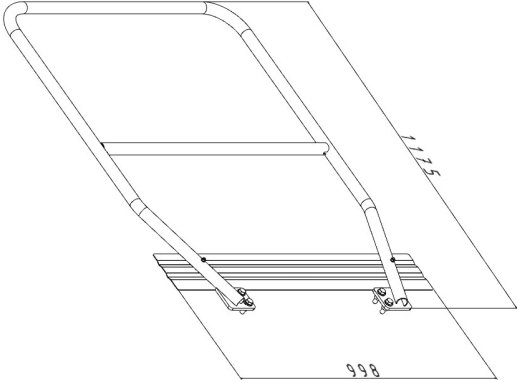
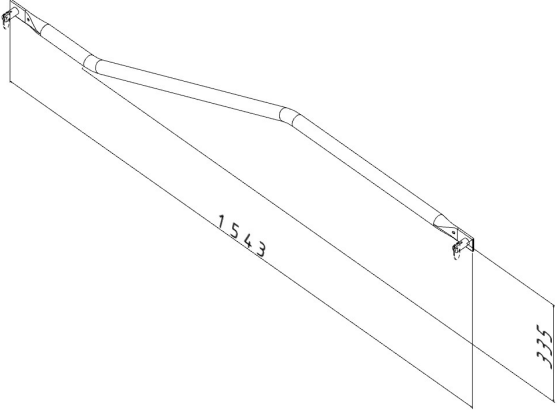
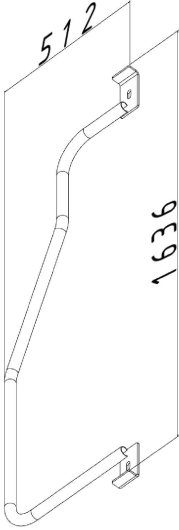
<p>SST-R4</p>  <p>Weight: 10.4 kg</p>	<p>SST-R9</p>  <p>Weight: 10.0 kg</p>
<p>SST-PO1</p>  <p>Weight: 2.5 kg</p>	<p>SST-R8</p> 

	Weight: 4.55 kg
--	-----------------

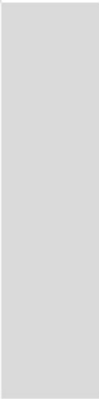

SST-F1

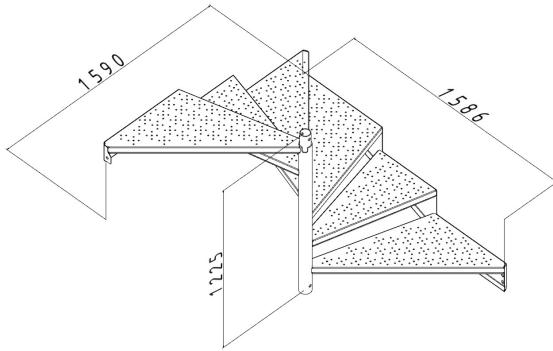

Weight: 59.5 kg

SST-RAP

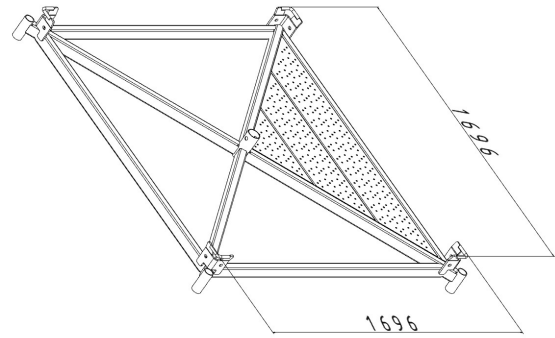

Weight: 63.7 kg

SST-S1

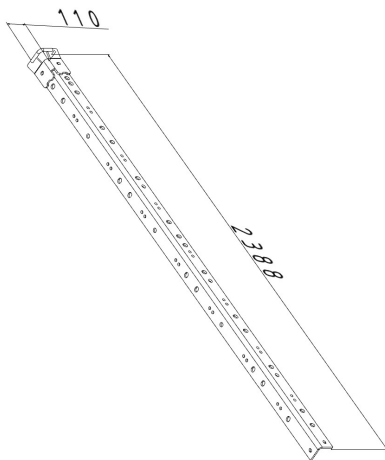

Weight: 21.5 kg

SST-P2a

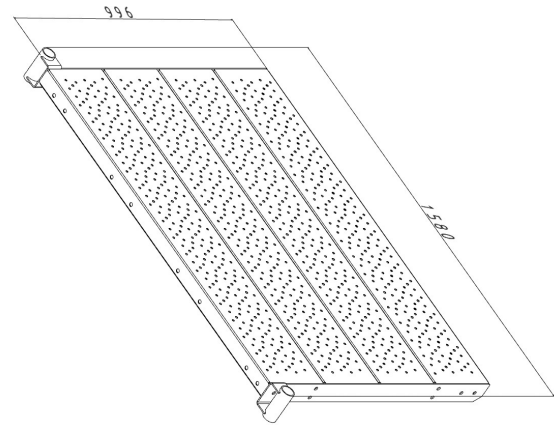

Weight: 38.7 kg

SST-P1

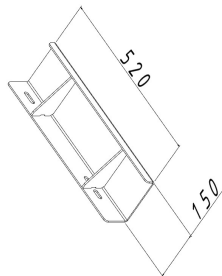

Weight: 4.6 kg

SST-L3

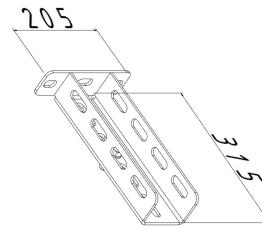

Weight: 2.8 kg

EPS-KS-A3

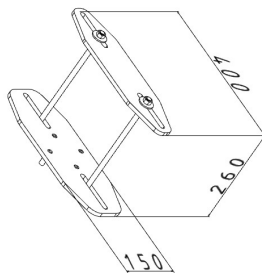

Weight: 7.23 kg

EPS-KS-A2

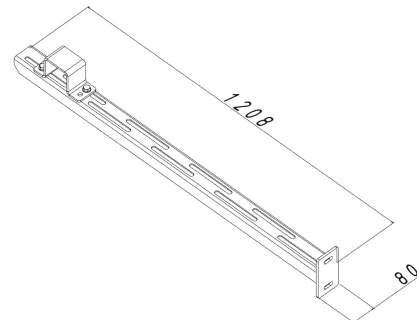

Weight: 7.32 kg

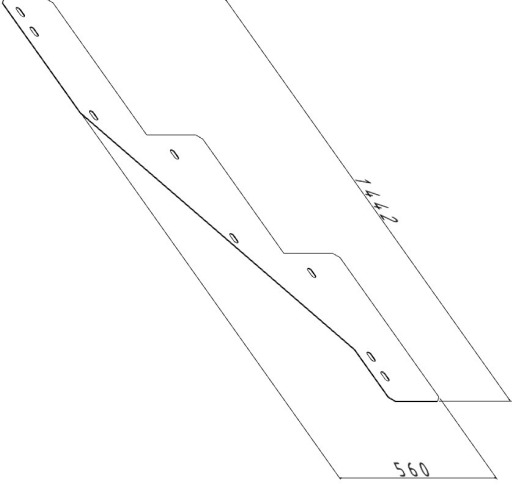
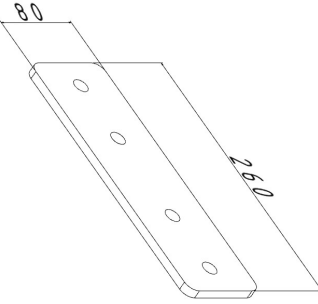
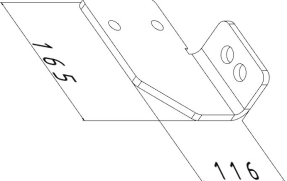
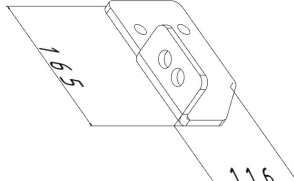
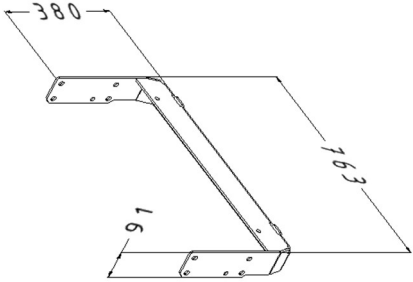
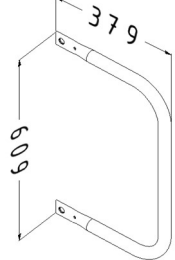
<p>SST-K1</p>  <p>Weight: 4.8 kg</p>	<p>SST-A3</p>  <p>Weight: 1.3 kg</p>
<p>SST-A1</p>  <p>Weight: 1.23 kg</p>	<p>SST-A2</p>  <p>Weight: 1.23 kg</p>
<p>SST-A4</p>  <p>Weight: 8.739 kg</p>	<p>SST-R10</p>  <p>Weight: 1.837 kg</p>

SST-R11

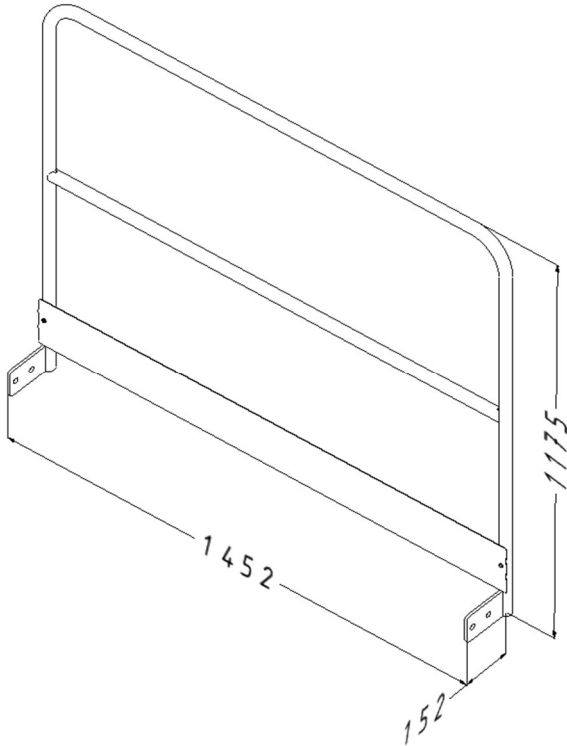

Weight: 11.751 kg

SST-E2

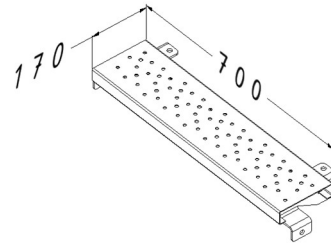

Weight: 4.325 kg

SST-WT1

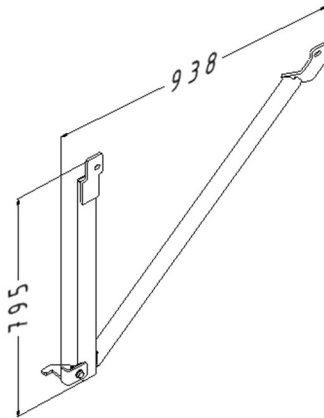

Weight: 7.294 kg

SST-WT2

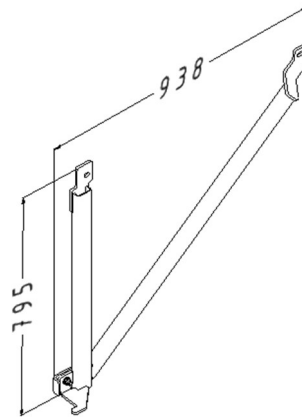

Weight: 7.294 kg

### 3. Graphical list of SST system fasteners

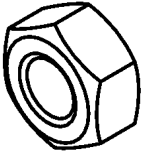
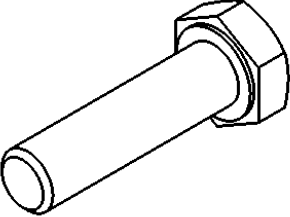
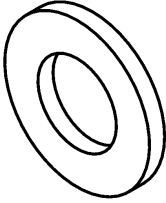
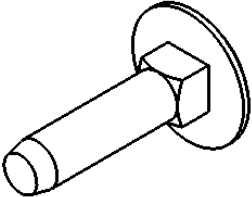
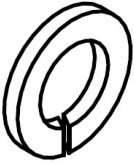
 <p>M6 M12 M16</p>	 <p>M12x40 M16x40 M16x100</p>	 <p>W6 W12 W16</p>
 <p>MZ6x45</p>	 <p>WS12 WS8</p>	

## 4. List of components of the SST system

The list of components in Table 1 shows the components of the temporary spiral staircase system and their quantities assembled depending on the configuration, and the type of system ordered by the customer (to be selected from the column designation, description of the component).

Tab 1. List of parts

No.	Diagram designation	Description of component	quantity in staircase base SST-POD1	quantity in intermediate module SST-KL1	quantity in descent platform SST-P2	quantity in descent step SST-P1	quantity in side descent SST-Z
1	SST-A3	Platform connector	0	0	2	0	0
2	SST-K1	Flight toeboard	0	4	0	0	0
3	SST-L3	Installation console	0	2	0	0	0
4	EPS-KS-A2	Console A2					
5	EPS-KS-A3	Console A3					
6	SST-R4	Closing railing	1	0	0	0	0
7	SST-R8	Closing railing 02	1	0	0	0	0
8	SST-R9	Platform railing	0	0	2	0	0
9	M-Z-POD-T32	Adjustable foot	4	0	2	0	0
10	SST-A1	Right platform console	0	0	1	0	0
11	SST-A2	Left platform console	0	0	1	0	0
12	SST-P2a	Descent platform frame	0	0	1	0	0
13	SST-F1	Staircase flight	0	2	0	0	0
14	SST-PO1	HandlePochwyt	0	8	0	0	0
15	SST-S1	Pole	0	4	0	0	0
16	SST-RAP	Base frame	1	0	0	0	0
17	SST-P1	Descent step	0	0	0	1	0
18	SST-A4	Stair connector TAS	0	0	0	0	1
19	SST-R10	Fill-in railing	0	0	0	0	2
20	SST-R11	Platform railing 02	0	0	0	0	1
21	SST-E2	Fill-in step	0	0	0	0	1
22	SST-WT1	Left platform support	0	0	0	0	1
23	SST-WT2	Right platform support	0	0	0	0	1

Tab 2. Contents of connector sets

Diagram designation	quantity in staircase base SST-POD1	quantity in intermediate module SST-KL1	quantity in descent platform SST-P2	quantity in descent step SST-P1	quantity in side descent SST-Z
M12x40	8	7	16	2	14
M16x40	0	13	2	0	4
M16x100	1	2	0	0	0
WG12x35	0	0	0	0	2
M12	8	7	16	2	16
M16	1	15	2	0	4
W6	0	0	0	0	0
W12	16	14	32	4	30
W16	2	30	4	0	8

Table 3. List of connection components for installation of the intermediate module SST-KL1

Diagram designation	Volume
M12x40	8
M16x40	13
M16x100	2
M12	8
M16	15
W12	16
W16	30



## 5. Staircase descent levels

Descent height	Module no.	Step no.	Descent side []
190	1	0	0
380	1	1	90
570	1	2	90
760	1	3	90
950	1	4	180
1140	1	5	180
1330	1	6	180
1520	1	7	270
1710	1	8	270
1900	1	9	270
2090	1	10	0
2280	1	11	0
<b>2470</b>	<b>1</b>	<b>12</b>	<b>0</b>
2660	2	1	90
2850	2	2	90
3040	2	3	90
3230	2	4	180
3420	2	5	180
3610	2	6	180
3800	2	7	270
3990	2	8	270
4180	2	9	270
4370	2	10	0
4560	2	11	0
<b>4750</b>	<b>2</b>	<b>12</b>	<b>0</b>
4940	3	1	90
5130	3	2	90
5320	3	3	90
5510	3	4	180
5700	3	5	180
5890	3	6	180
6080	3	7	270
6270	3	8	270
6460	3	9	270
6650	3	10	0
6840	3	11	0
<b>7030</b>	<b>3</b>	<b>12</b>	<b>0</b>
7220	4	1	90
7410	4	2	90
7600	4	3	90
7790	4	4	180
7980	4	5	180
8170	4	6	180
8360	4	7	270
8550	4	8	270
8740	4	9	270
8930	4	10	0
9120	4	11	0
<b>9310</b>	<b>4</b>	<b>12</b>	<b>0</b>

Descent height	Module no.	Step no.	Descent side []
9500	5	1	90
9690	5	2	90
9880	5	3	90
10070	5	4	180
10260	5	5	180
10450	5	6	180
10640	5	7	270
10830	5	8	270
11020	5	9	270
11210	5	10	0
11400	5	11	0
<b>11590</b>	<b>5</b>	<b>12</b>	<b>0</b>
11780	6	1	90
11970	6	2	90
12160	6	3	90
12350	6	4	180
12540	6	5	180
12730	6	6	180
12920	6	7	270
13110	6	8	270
13300	6	9	270
13490	6	10	0
13680	6	11	0
<b>13870</b>	<b>6</b>	<b>12</b>	<b>0</b>
14060	7	1	90
14250	7	2	90
14440	7	3	90
14630	7	4	180
14820	7	5	180
15010	7	6	180
15200	7	7	270
15390	7	8	270
15580	7	9	270
15770	7	10	0
15960	7	11	0
<b>16150</b>	<b>7</b>	<b>12</b>	<b>0</b>
16340	8	1	90
16530	8	2	90
16720	8	3	90
16910	8	4	180
17100	8	5	180
17290	8	6	180
17480	8	7	270
17670	8	8	270
17860	8	9	270
18050	8	10	0
18240	8	11	0
<b>18430</b>	<b>8</b>	<b>12</b>	<b>0</b>



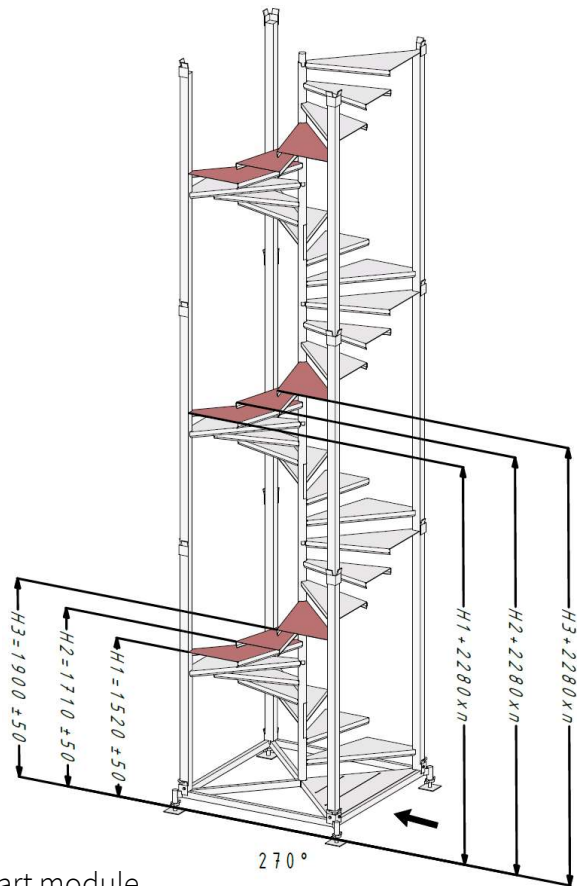
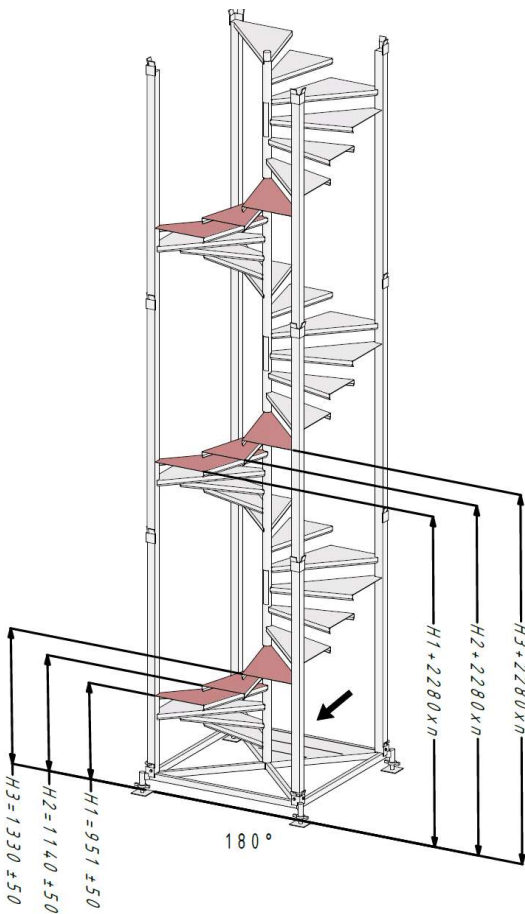
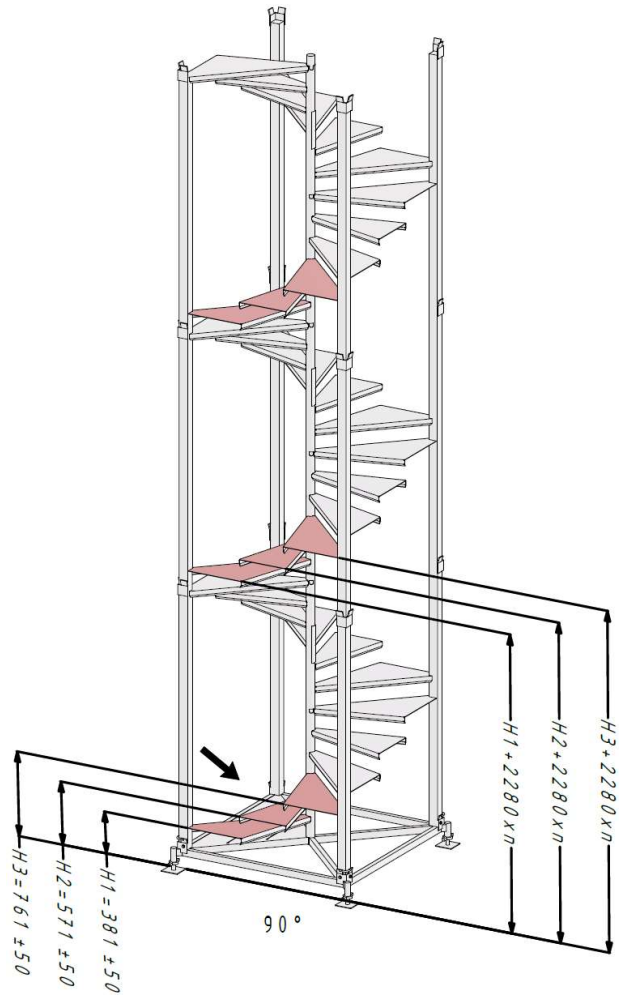
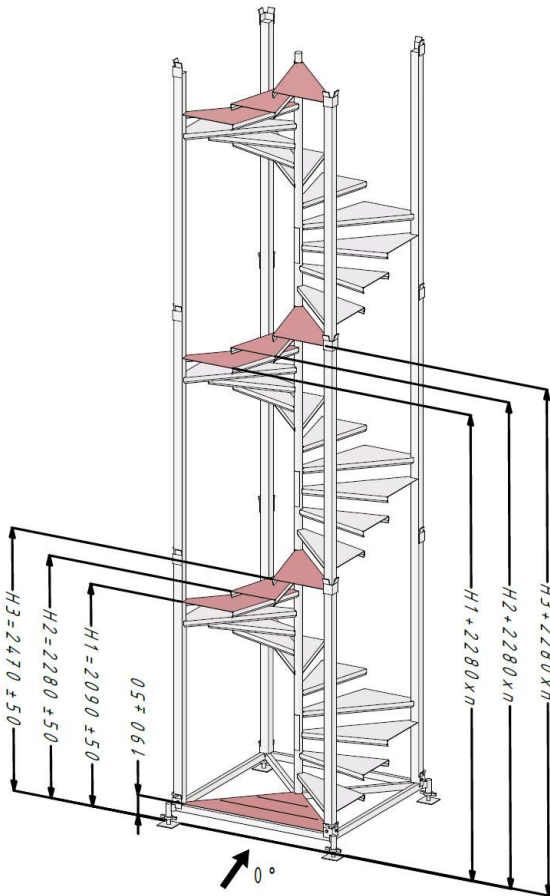

The values in bold apply to the final step in the given staircase module.



The arrow shows the direction of entry on the start module.

6. List of tools necessary of the installation of the temporary spiral staircase

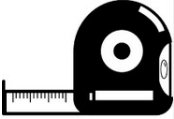
Tab 3. List of tools

	<p>Wrenches: 24,19,10</p>
	<p>Spirit level</p>
	<p>Measuring tape</p>
	<p>Lifting device with a lifting capacity of min. 1 t</p>

## 7. Installation operations for individual SST system components

The assembly instructions have been made to show how to assemble the various components of the temporary spiral staircase system.

### 6.1 - Installation of the base module

The base is installed by seating the platform frame on four feet. The feet may be seated only on hardened ground, while ensuring proper drainage. Another step is perfect base levelling. Make sure every foot is supported on the ground.

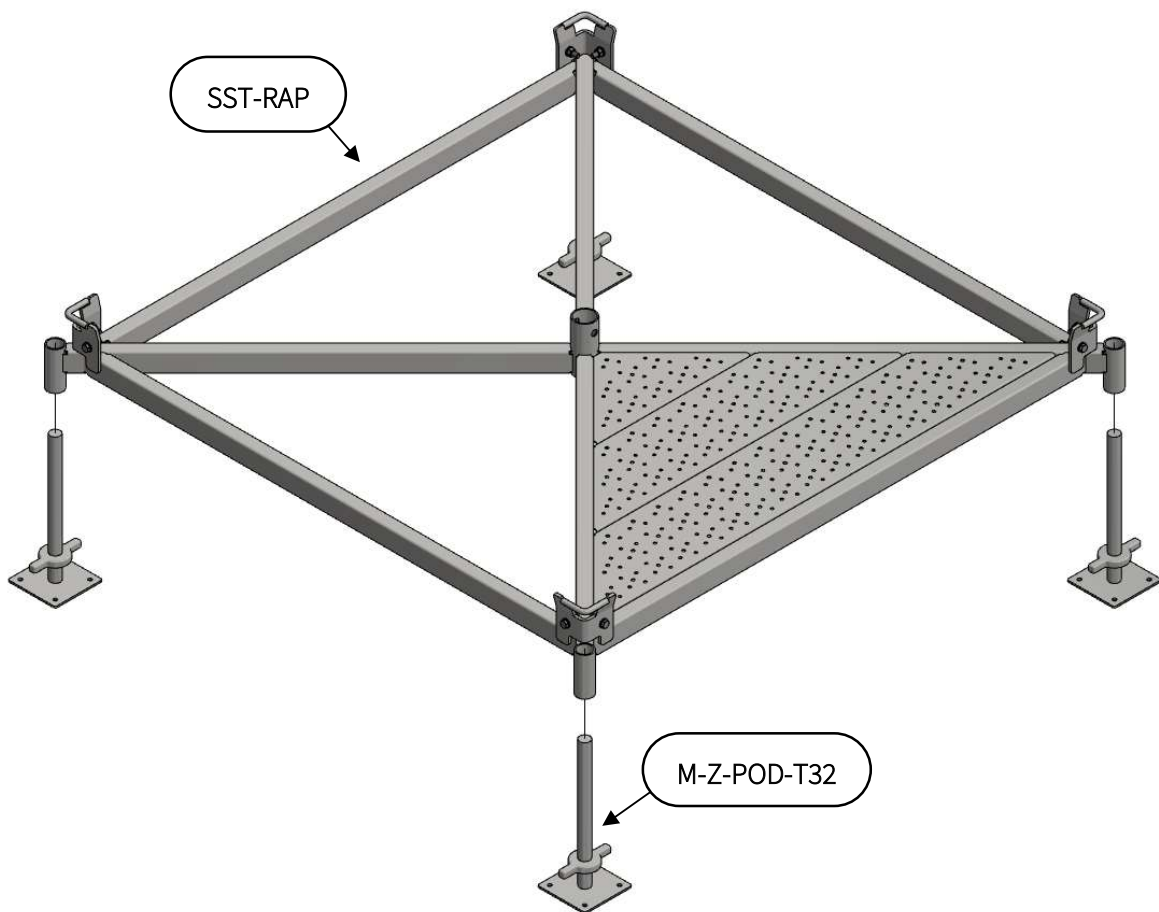

If the staircase is delivered to the site assembled, skip sections: 6.2, 6.3, 6.4

6.2 - Start the installation of the intermediate module by screwing the central poles together

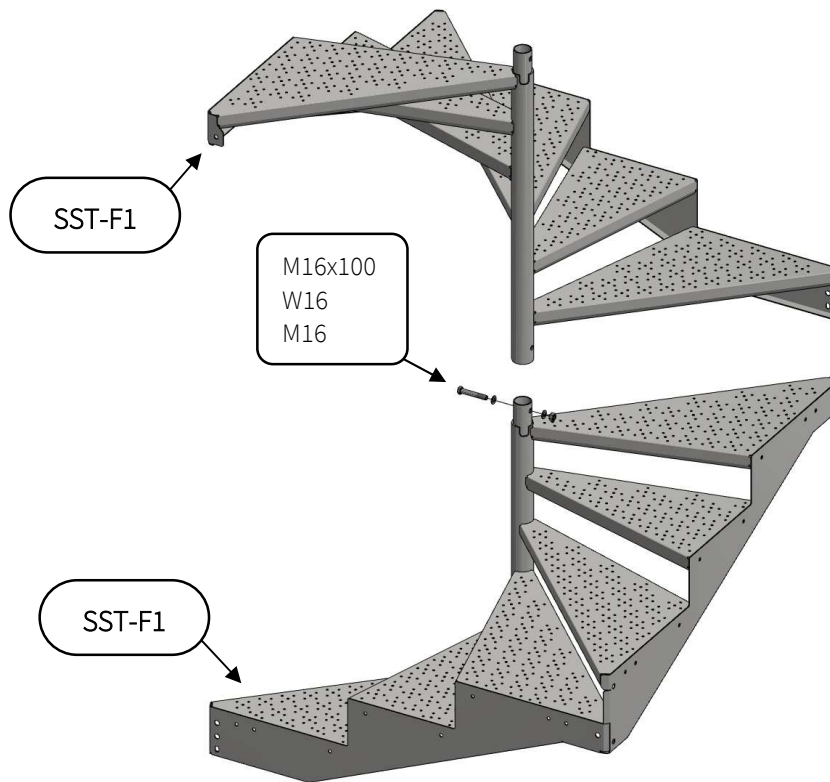

6.3 - Next, tighten the poles in the corners

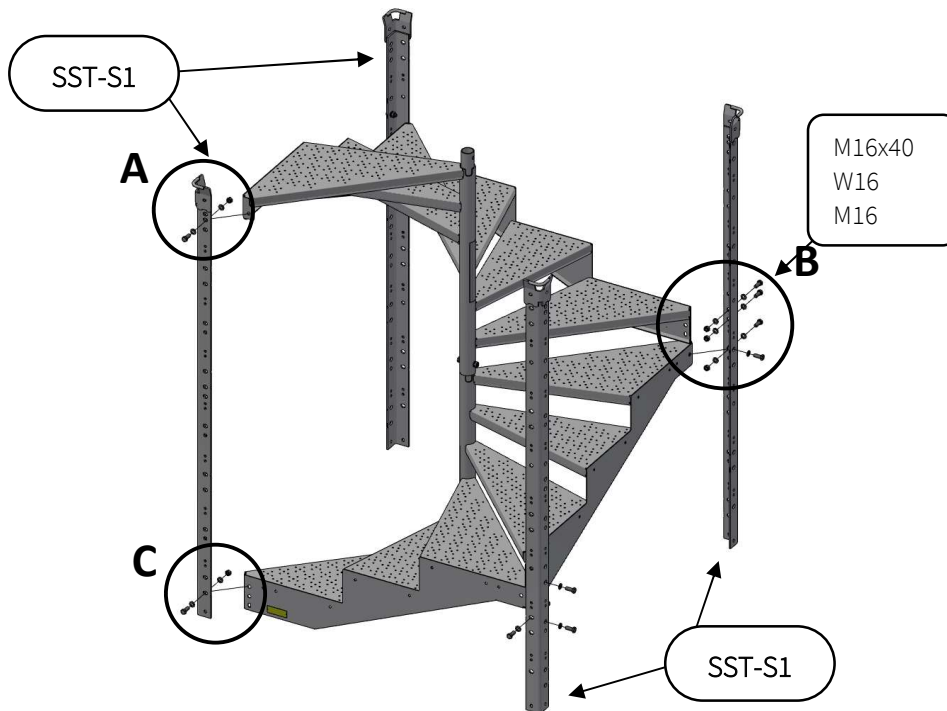

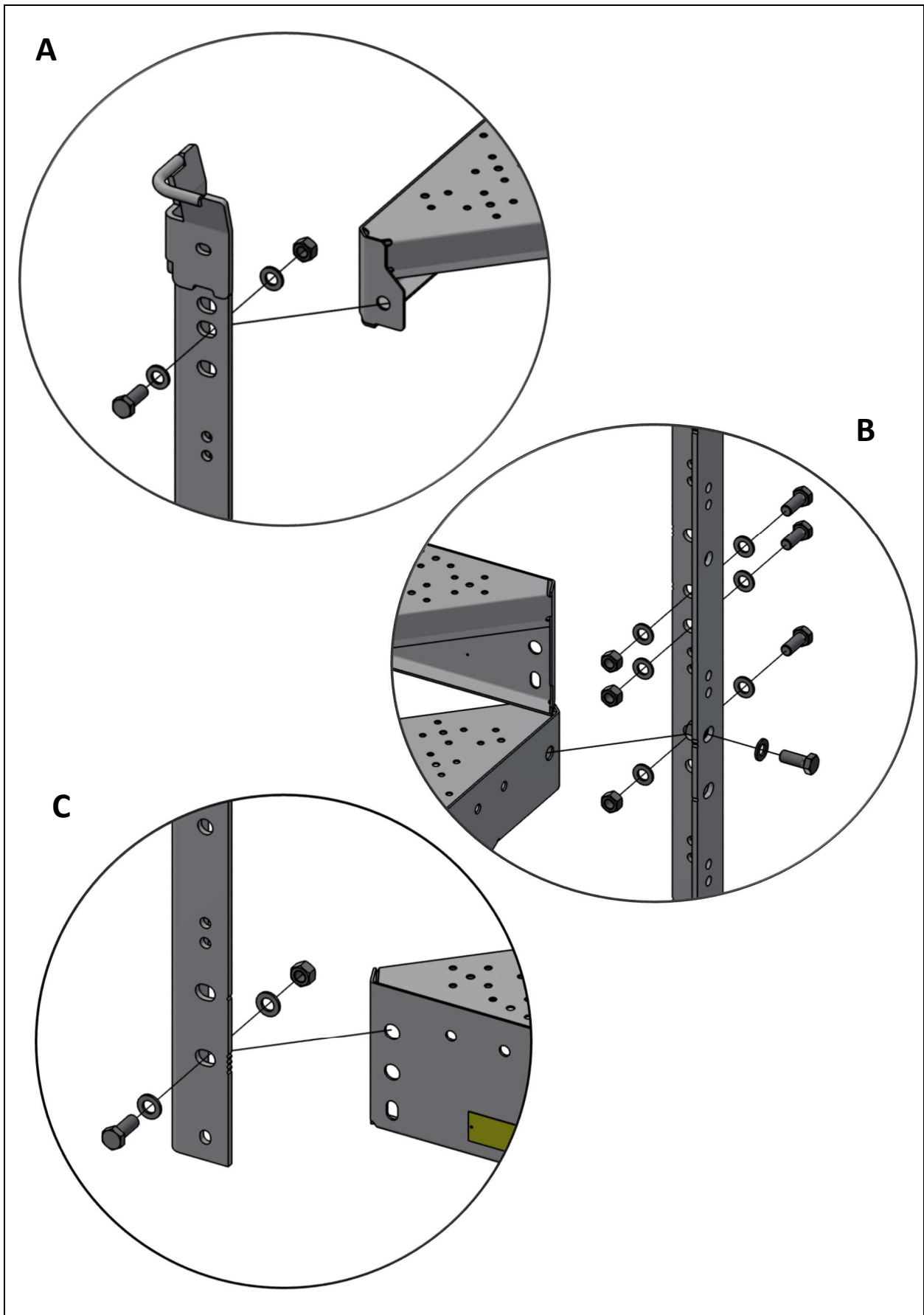



6.4 - Installation of railings in the intermediate module

Make sure every safety pin is secured

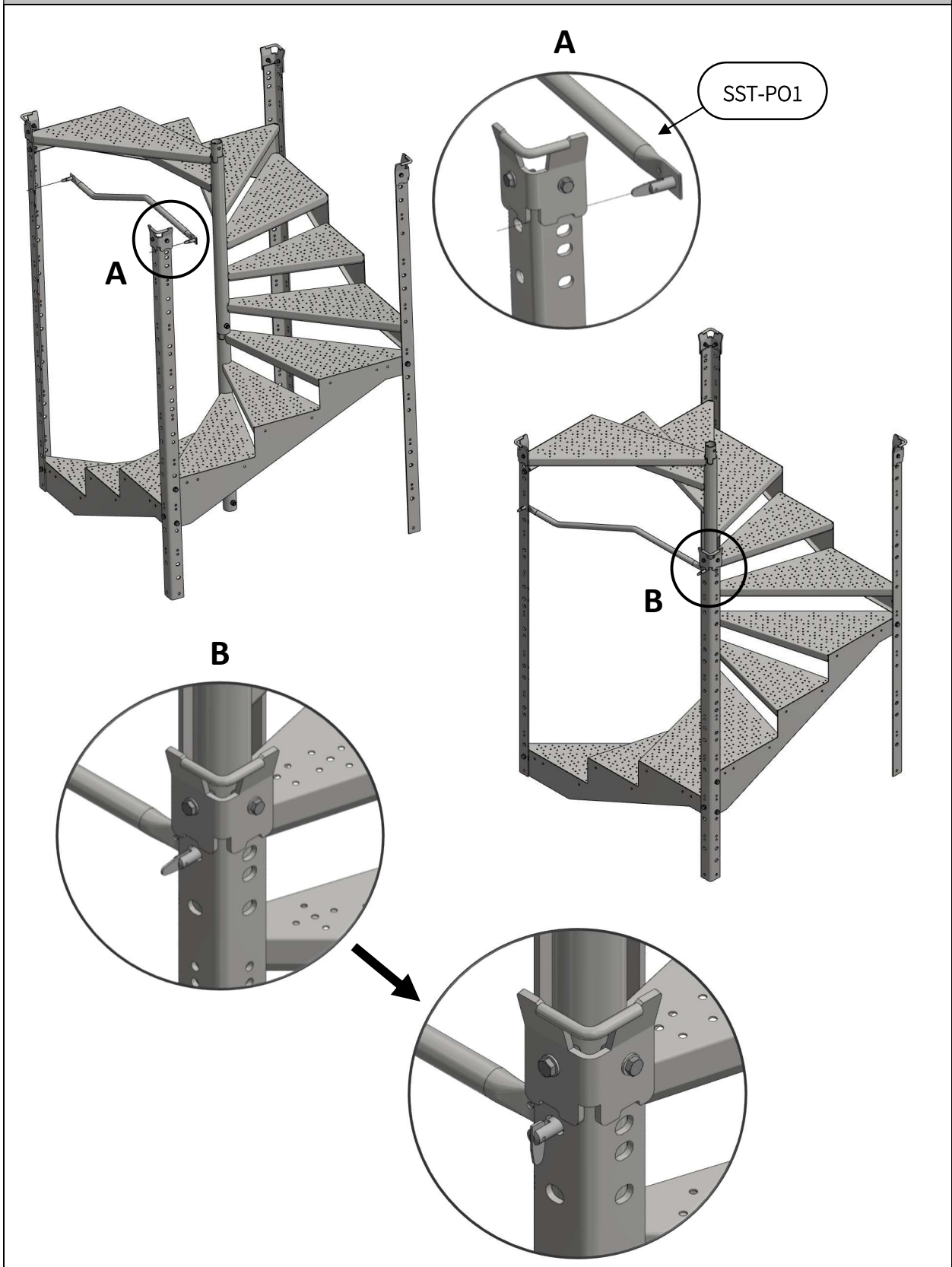

The staircases are delivered with the railing in transport configuration.

After setting the staircase, switch the railing to use configuration.

To select the appropriate configuration, follow the sticker on the central pole. The number of notches on the side poles shows the openings to attach the railing to.

### Use configuration of the railing

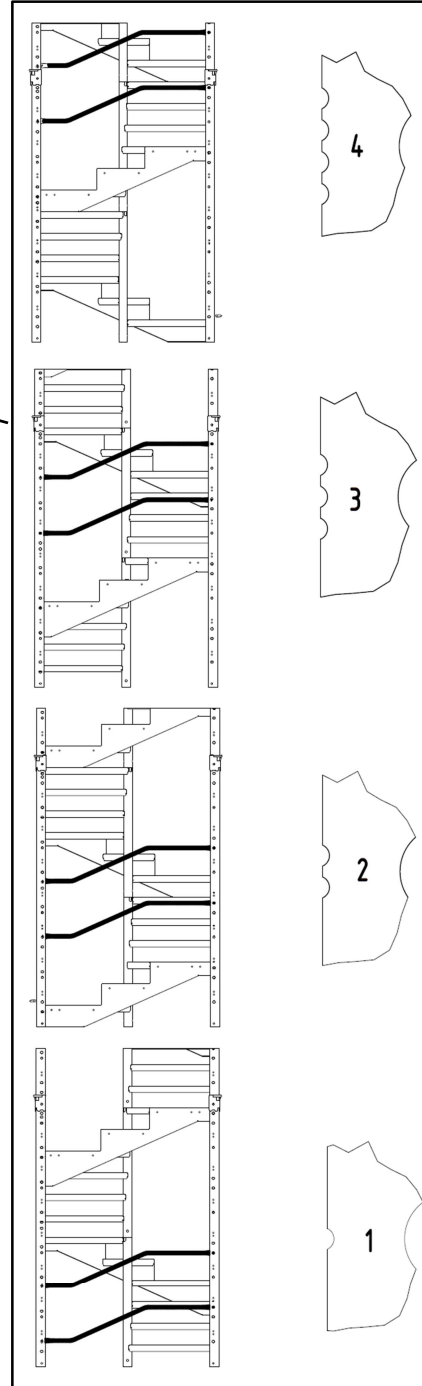
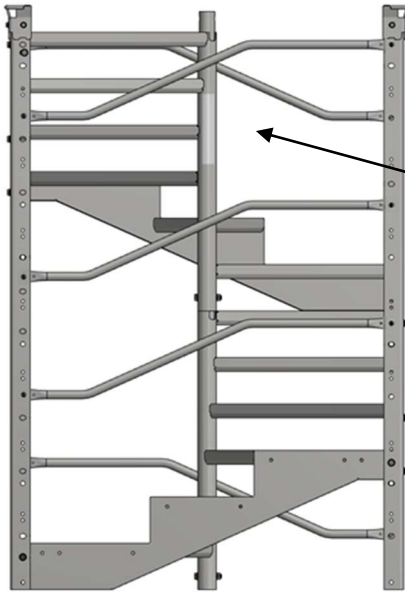



During the installation, disassembly and transport, switch the railing to transport configuration.

To select the appropriate configuration, follow the sticker on the central pole. The number of notches on the side poles shows the openings to attach the railing to.

### Transport configuration of the railing

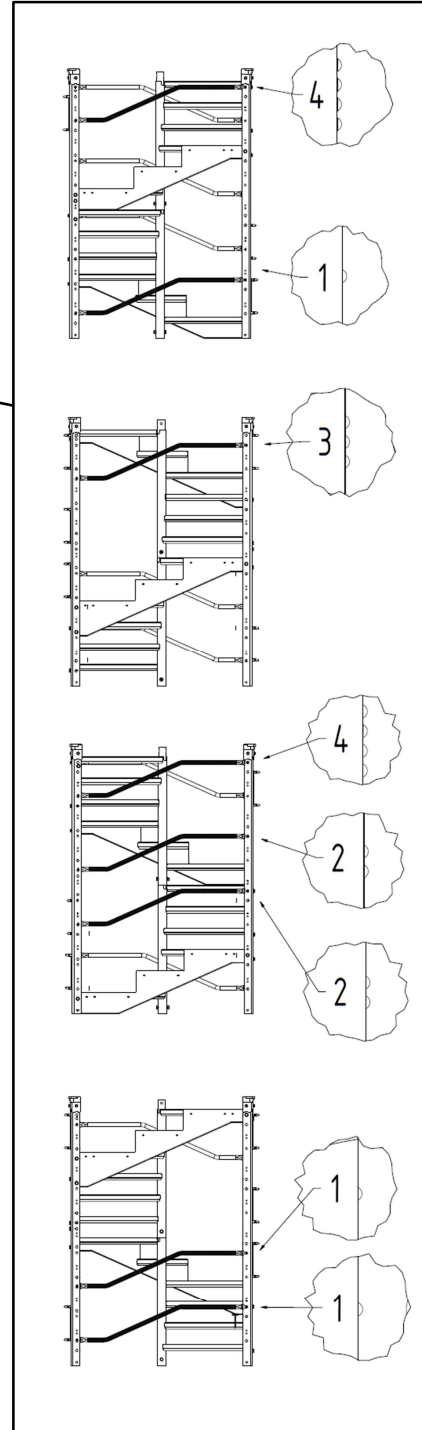
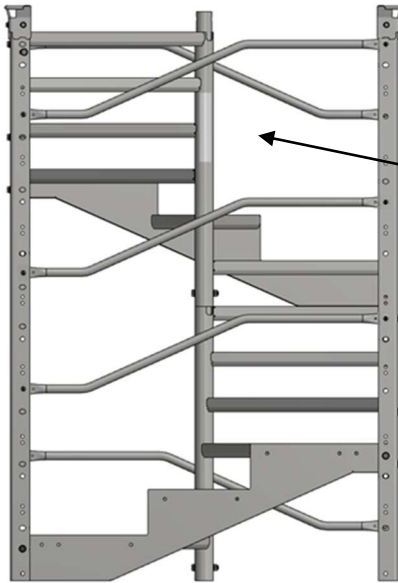

6.5 - Connection of the base and the intermediate module

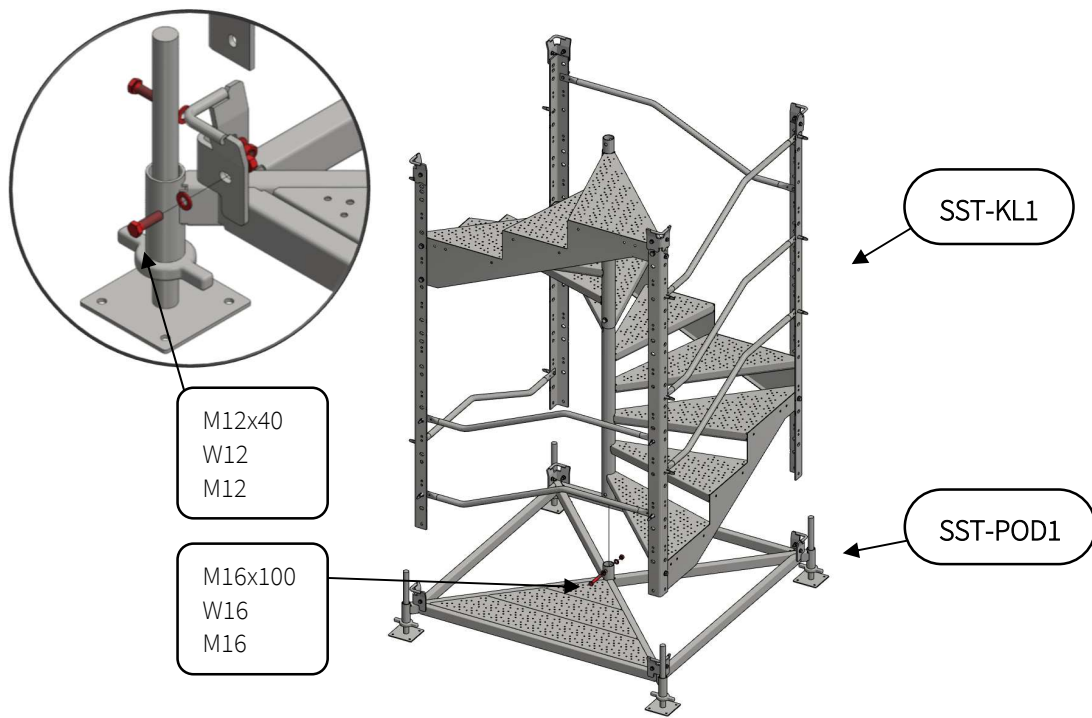

6.6 - Installation of another intermediate module

Maximum eight modules may be set together.

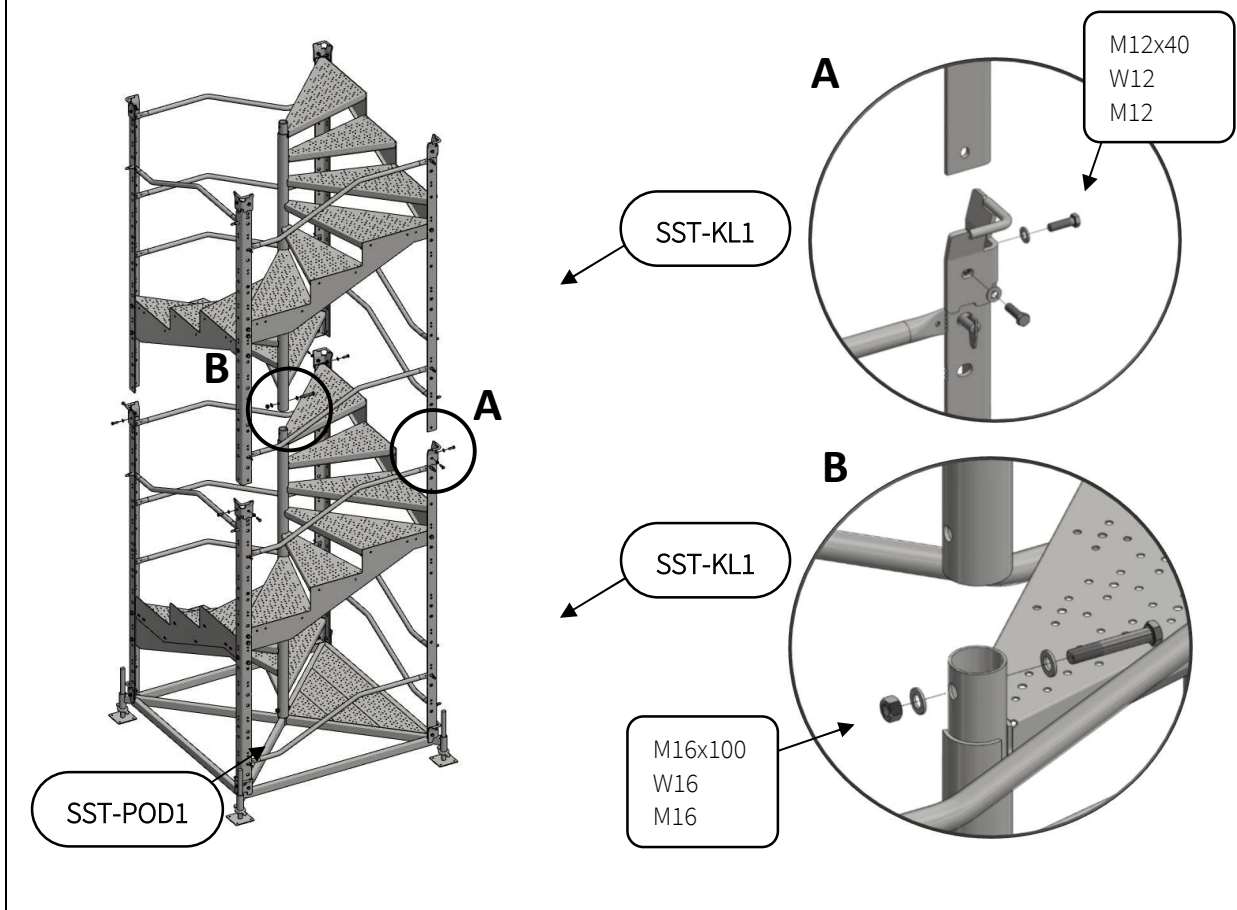

**6.7 - Installation of the descent step**

The stairs flight design enables step installation in three positions.

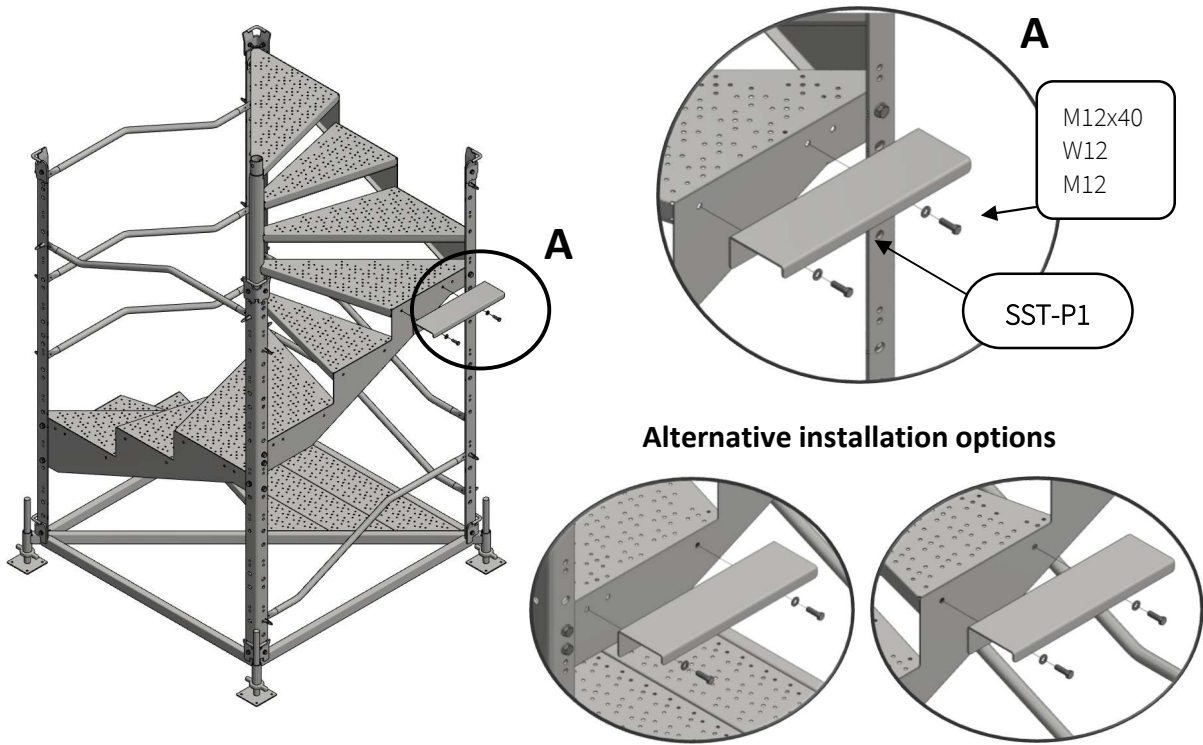

**6.8 - Installation of stabilising consoles.**

The consoles are necessary at the second and final module. Stabilise other modules with consoles at every other intermediate staircase. Install two consoles per module. Consoles SST-L3, EPS-KS-A2 and EPS-KS-A2 are used interchangeably. Install the consoles successively with staircase erection.

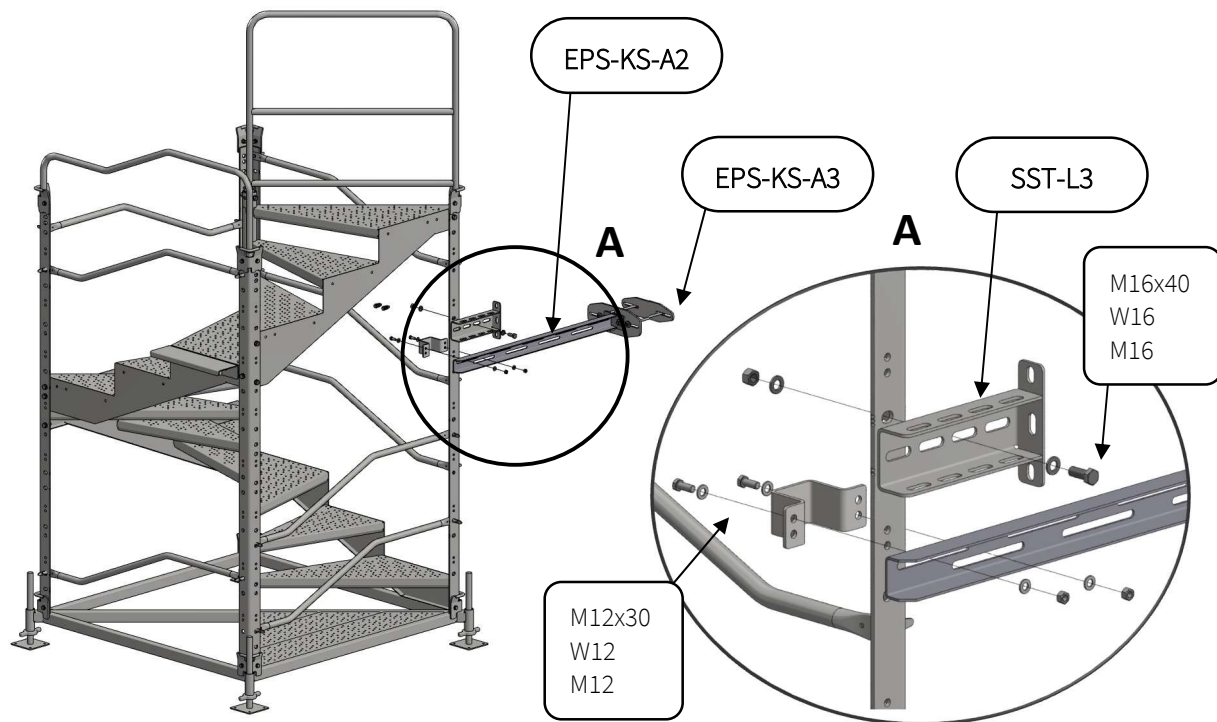

6.9 - Examples of installation of stabilising consoles

Consoles SST-L3 and EPS-KS-A3 should be anchored/screwed to the existing structure. In addition, the console EPS-KS-A3 may be installed as steel pole clamp.

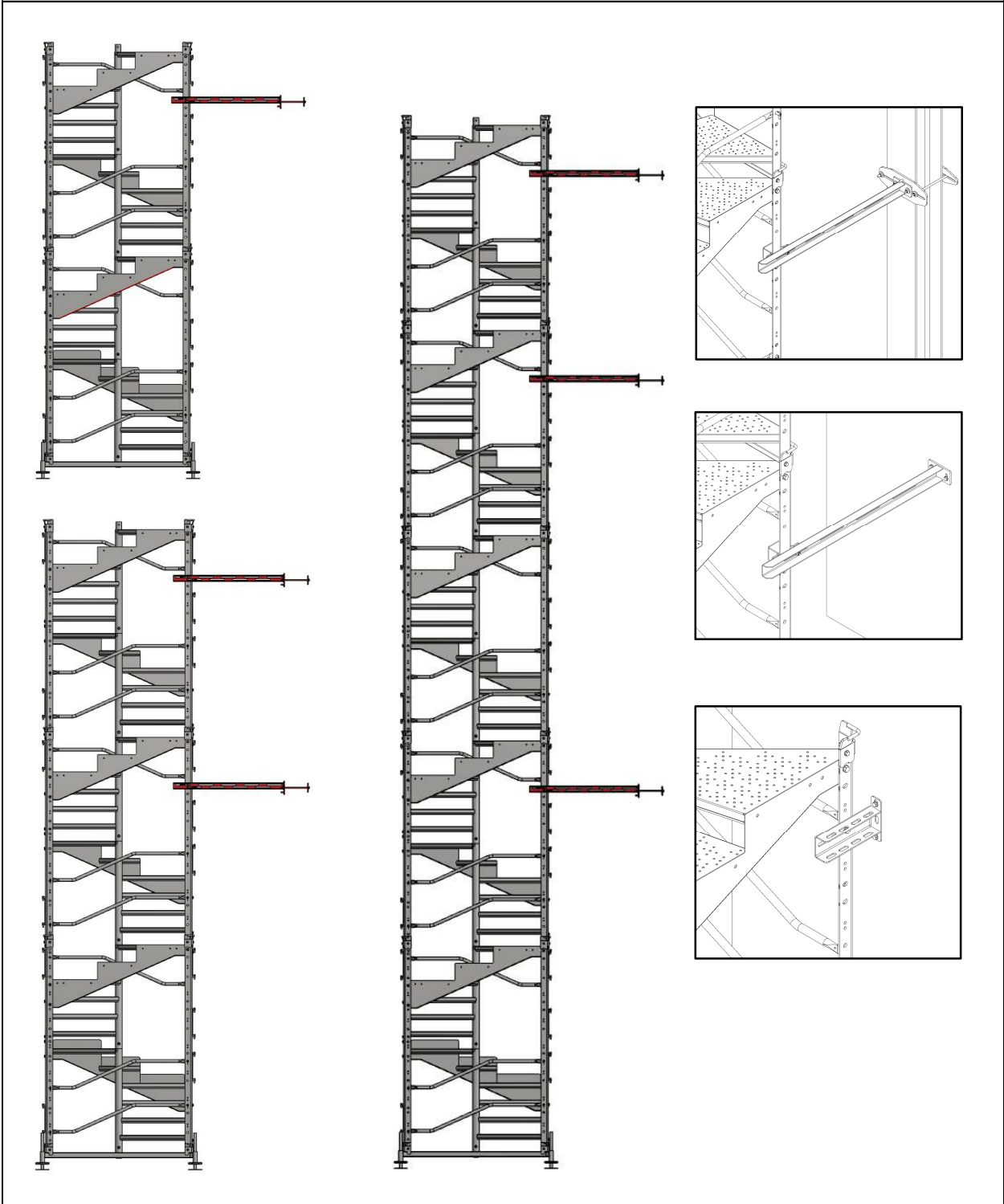



6.10 - Installation of the railing R4 of the top module

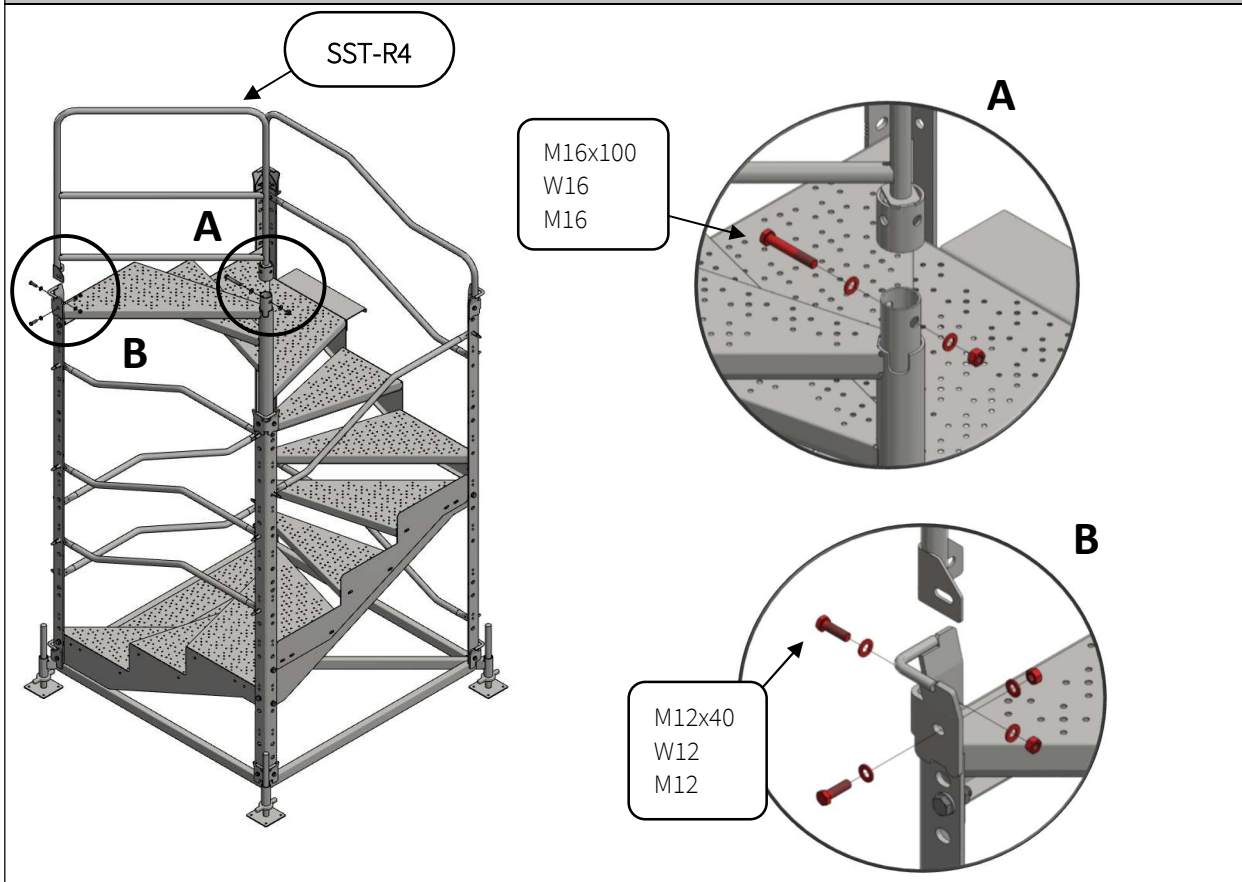

6.11 - Installation of the railing R8 of the top module

For proper protection and full use of the staircase, install safety railing for the descent from the top staircase.

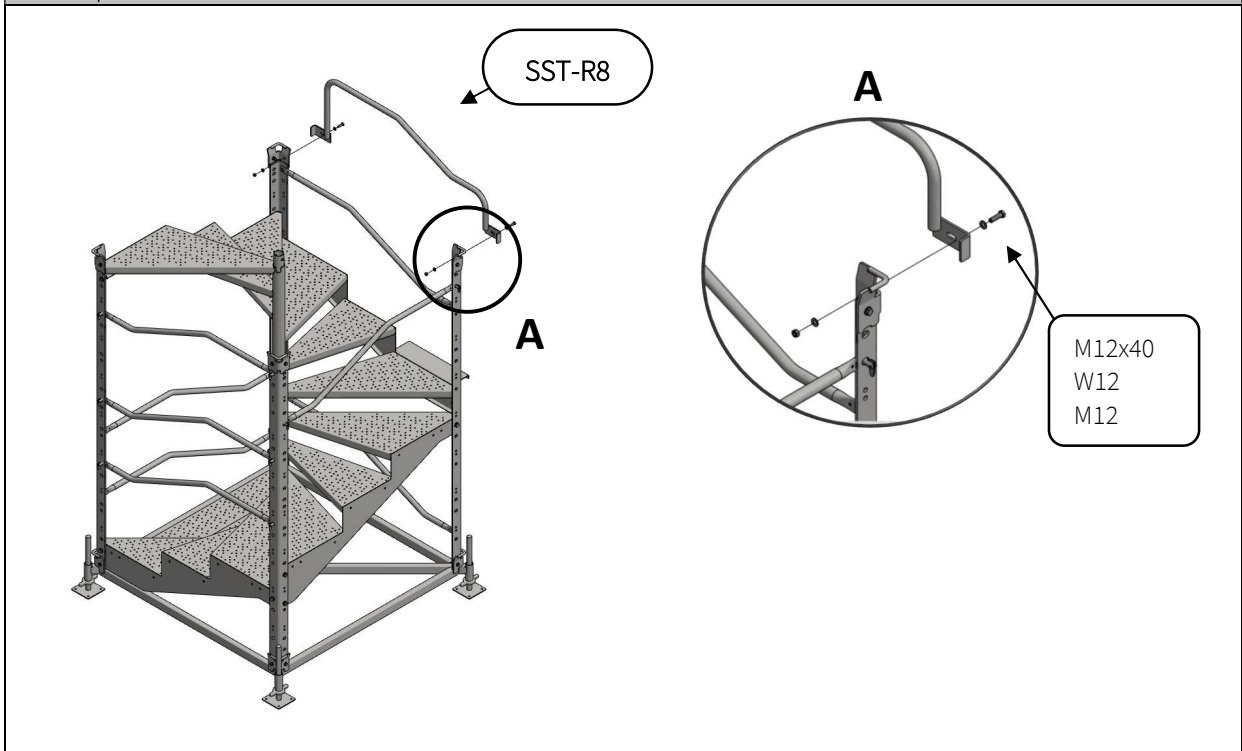

The top module railing should be installed to secure the stairs end. The installation depends on the staircase descent location.

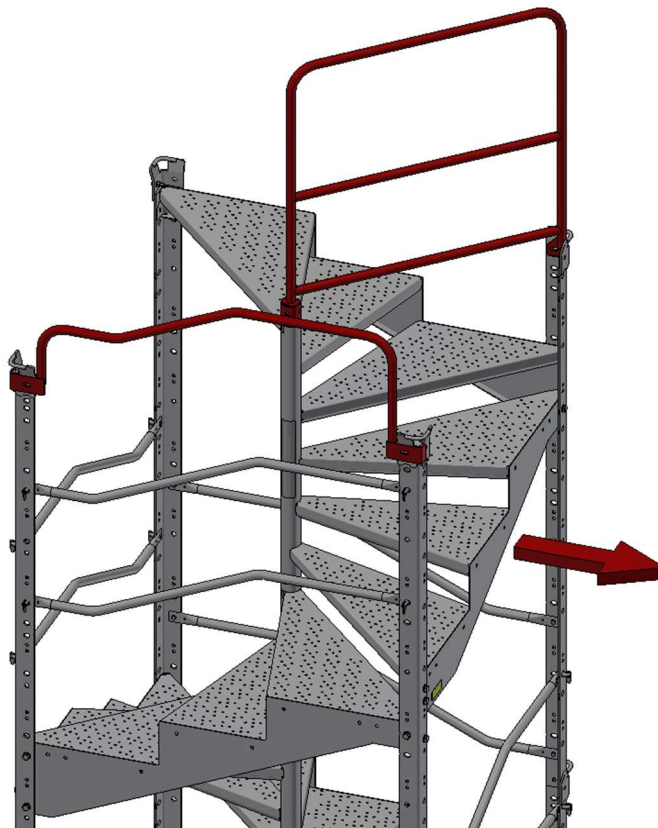



6.12 - Installation of the descent platform

The maximum distance from the wall structure, at which the staircase is placed, is 80 cm.

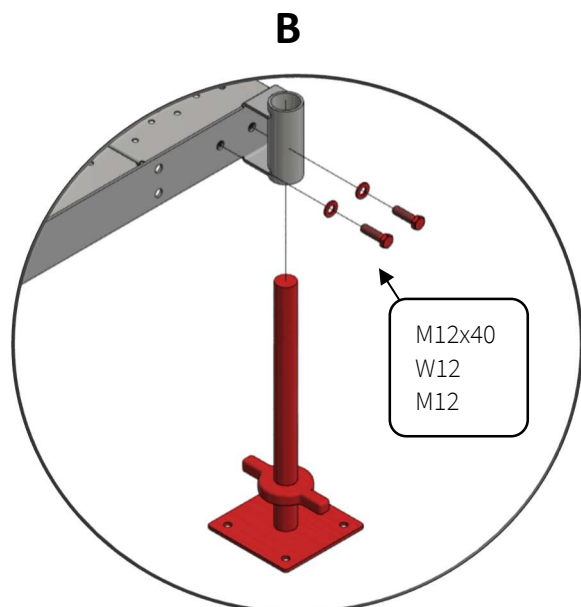
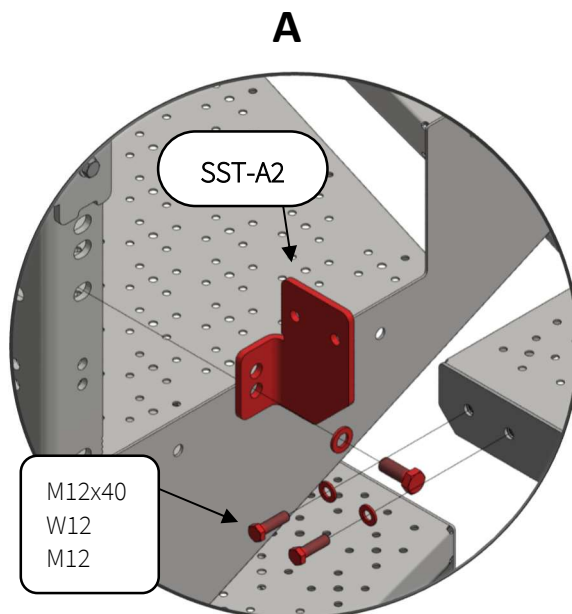
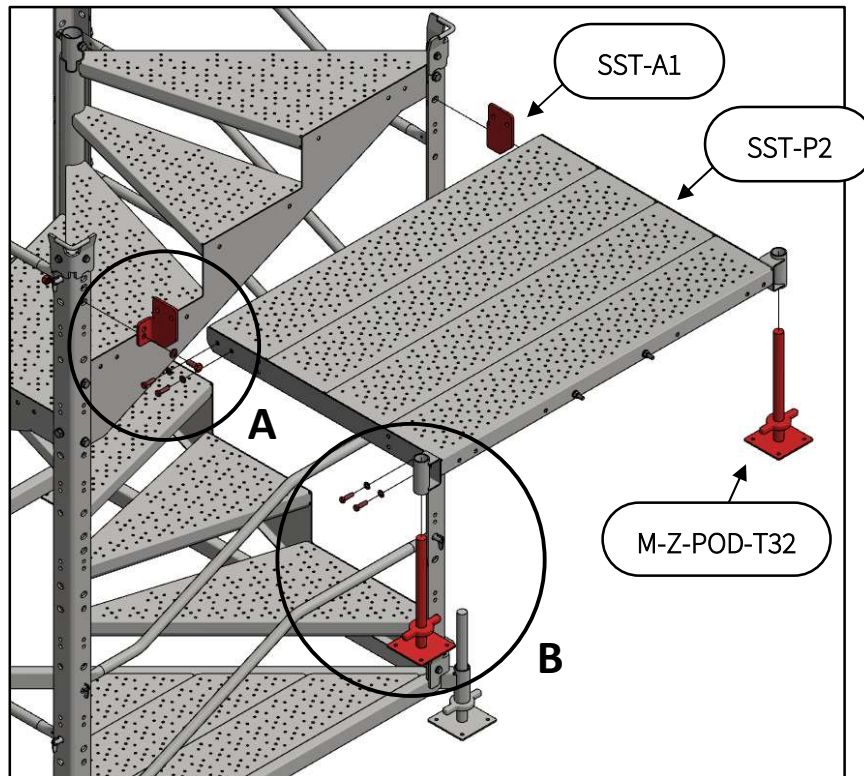



BOTTOM AND MIDDLE STEP

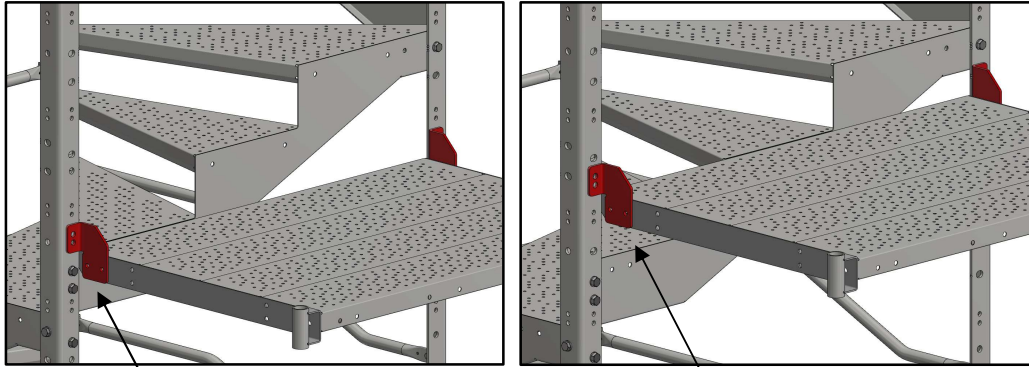

SST-A1

SST-A1

TOP STEP

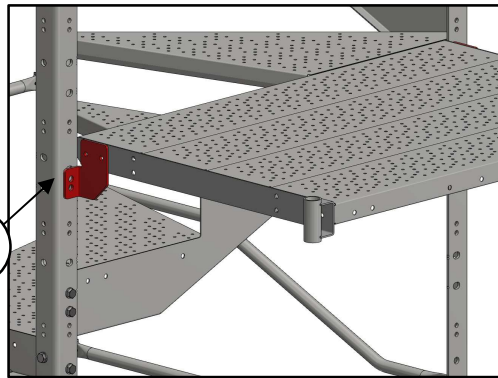

SST-A2

6.13 - Optional installation of another descent platform

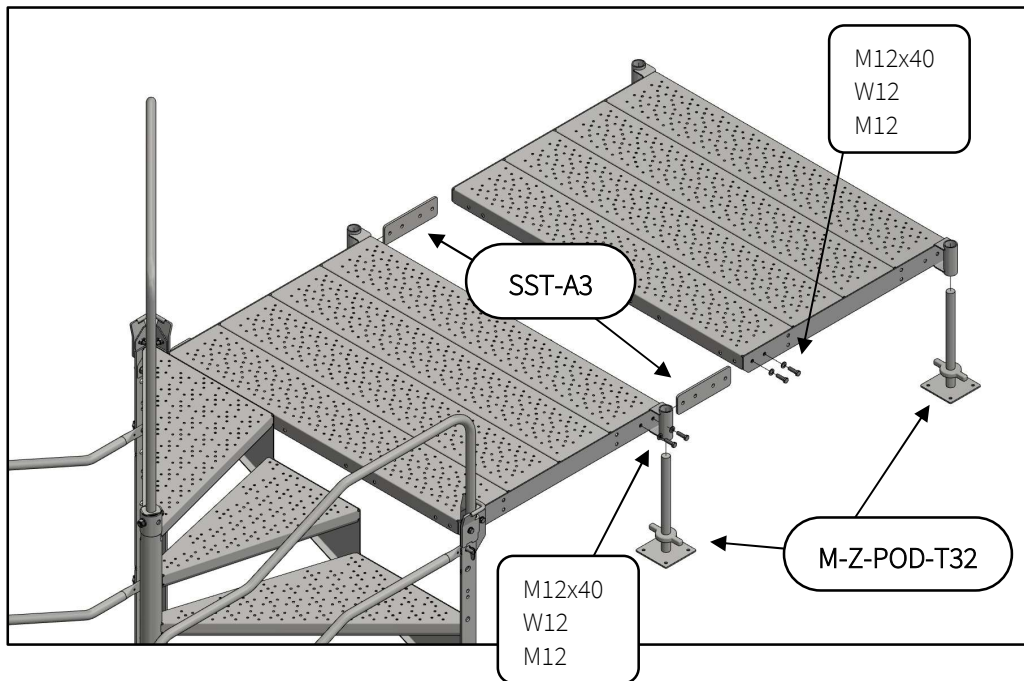

M12x40  
W12  
M12

SST-A3

M-Z-POD-T32

M12x40  
W12  
M12

6.14 - Installation of the descent platform railing

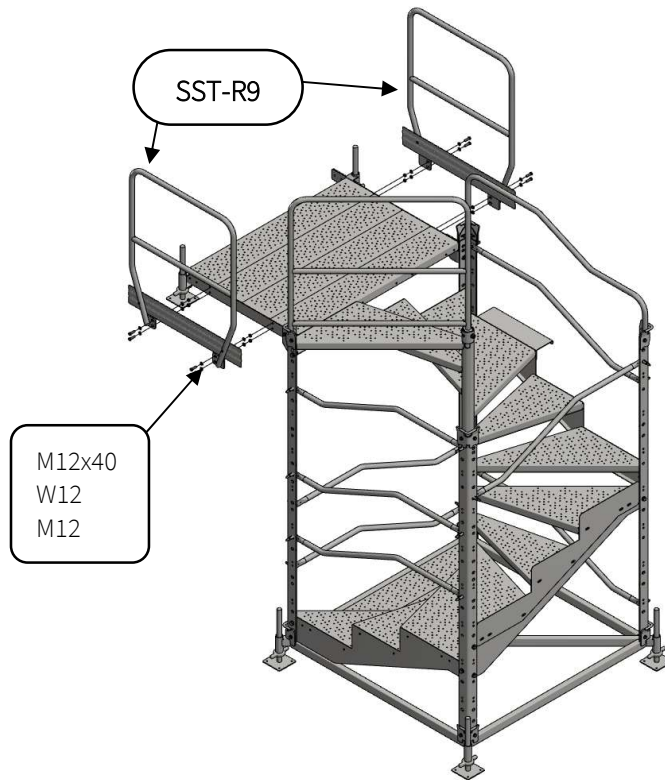

6.15 - Installation of optional toeboard on stair flights

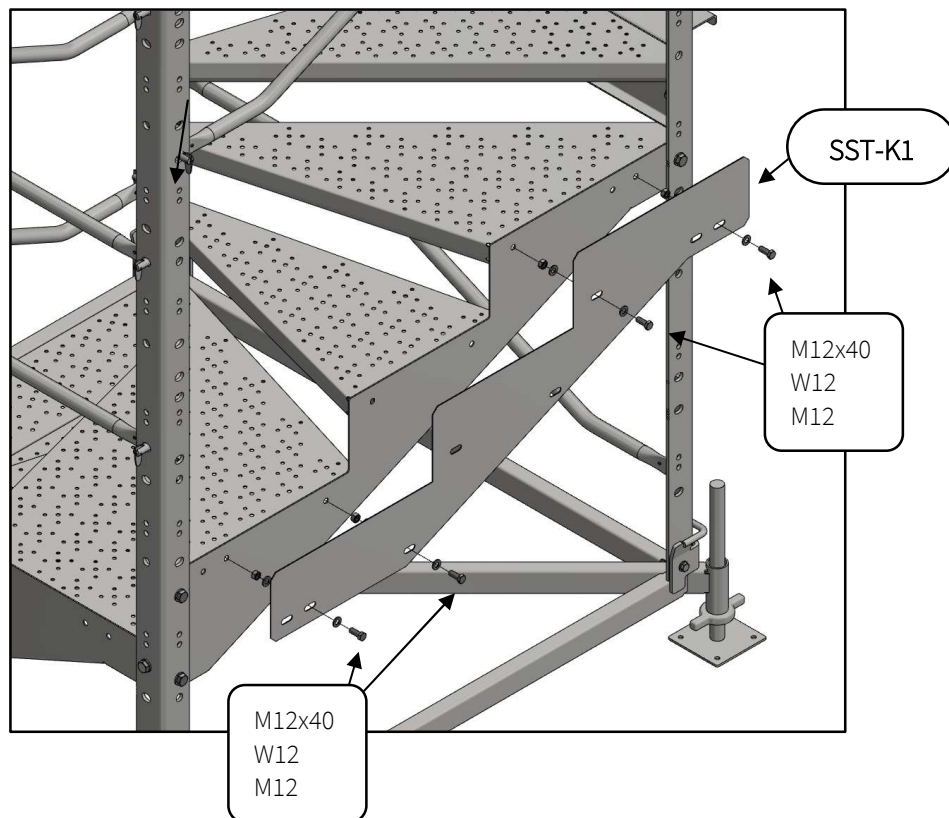

### 6.16 - Installation of TAS side descent

The TAS stairs may be attached to the SST staircase platform to provide the side descent from the staircase. The stairs may be installed with maximum 6 steps. The staircase segment, to which the side descent platform is screwed, should be anchored to the structure in the descent direction.

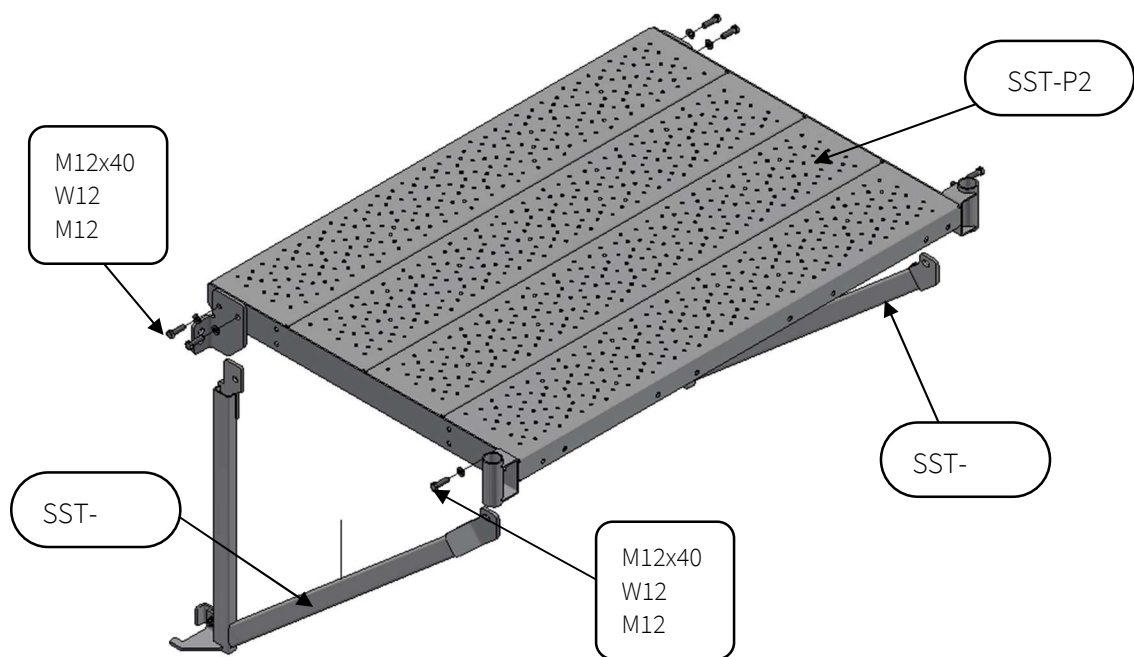
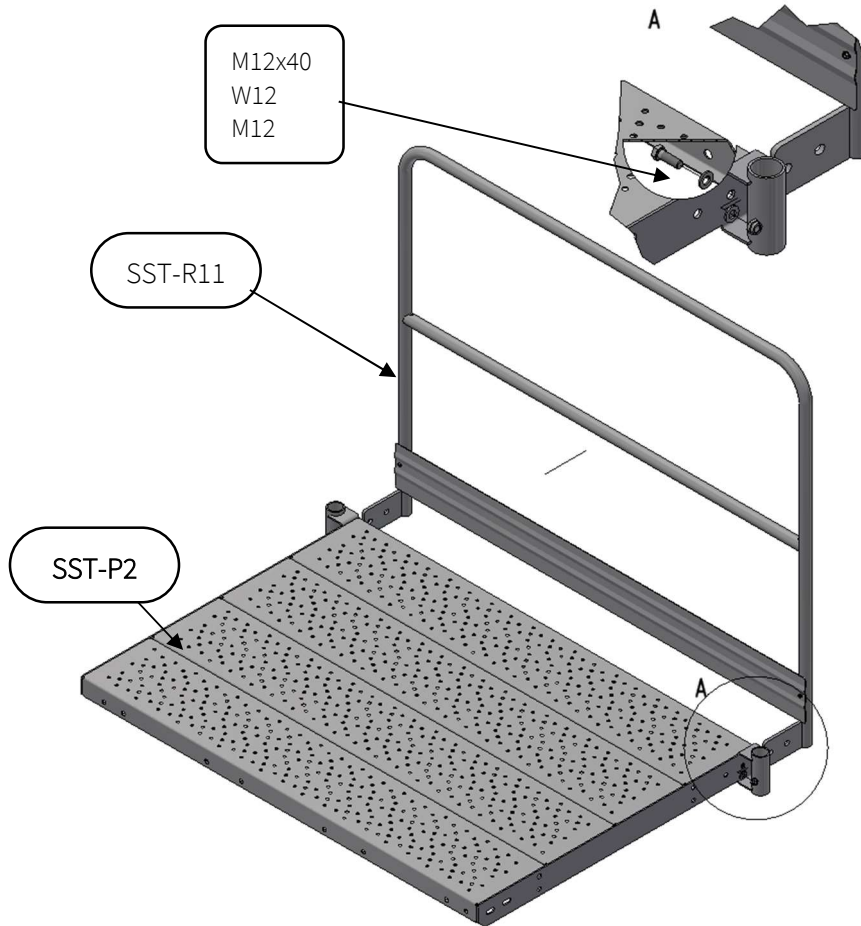

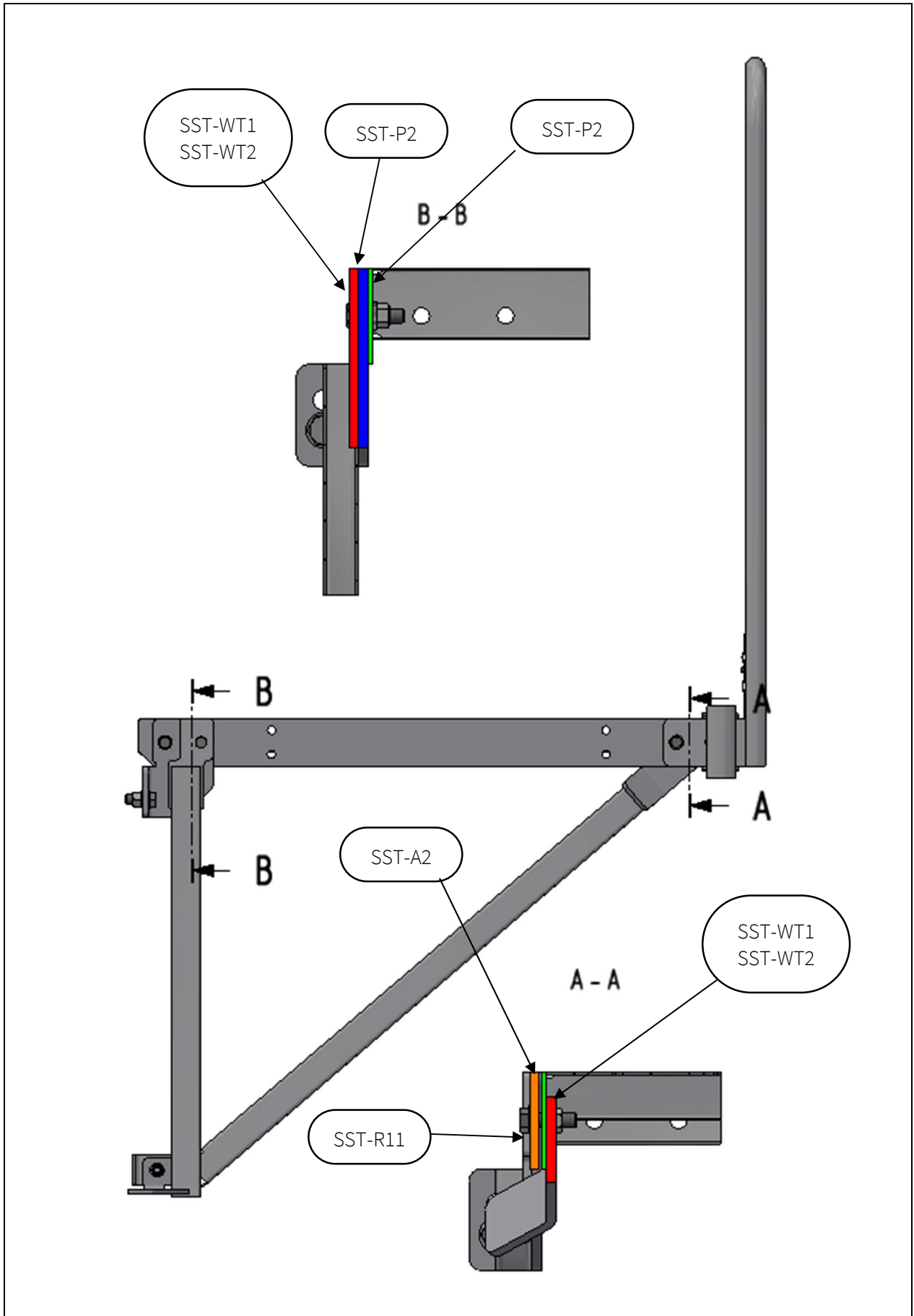





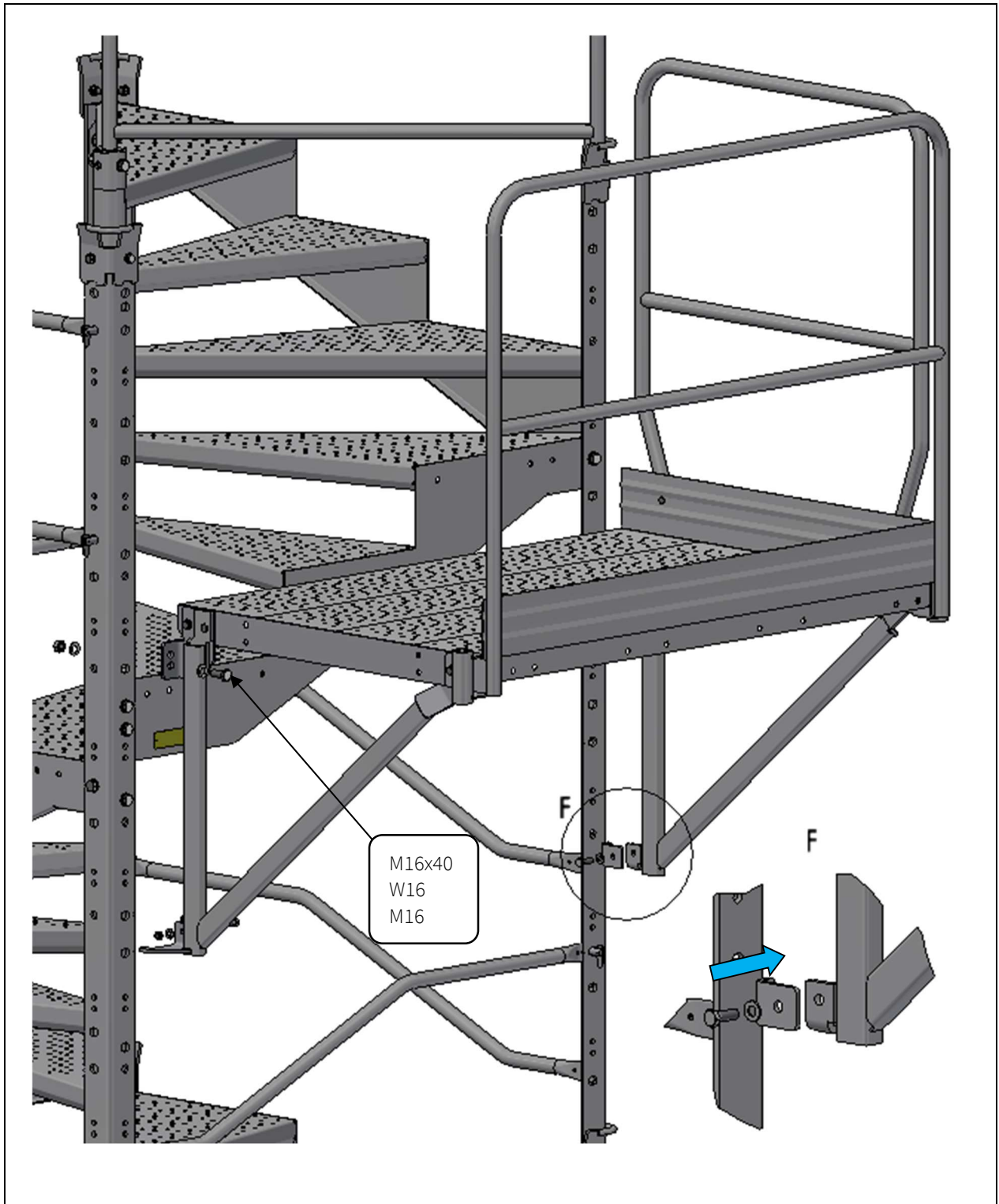

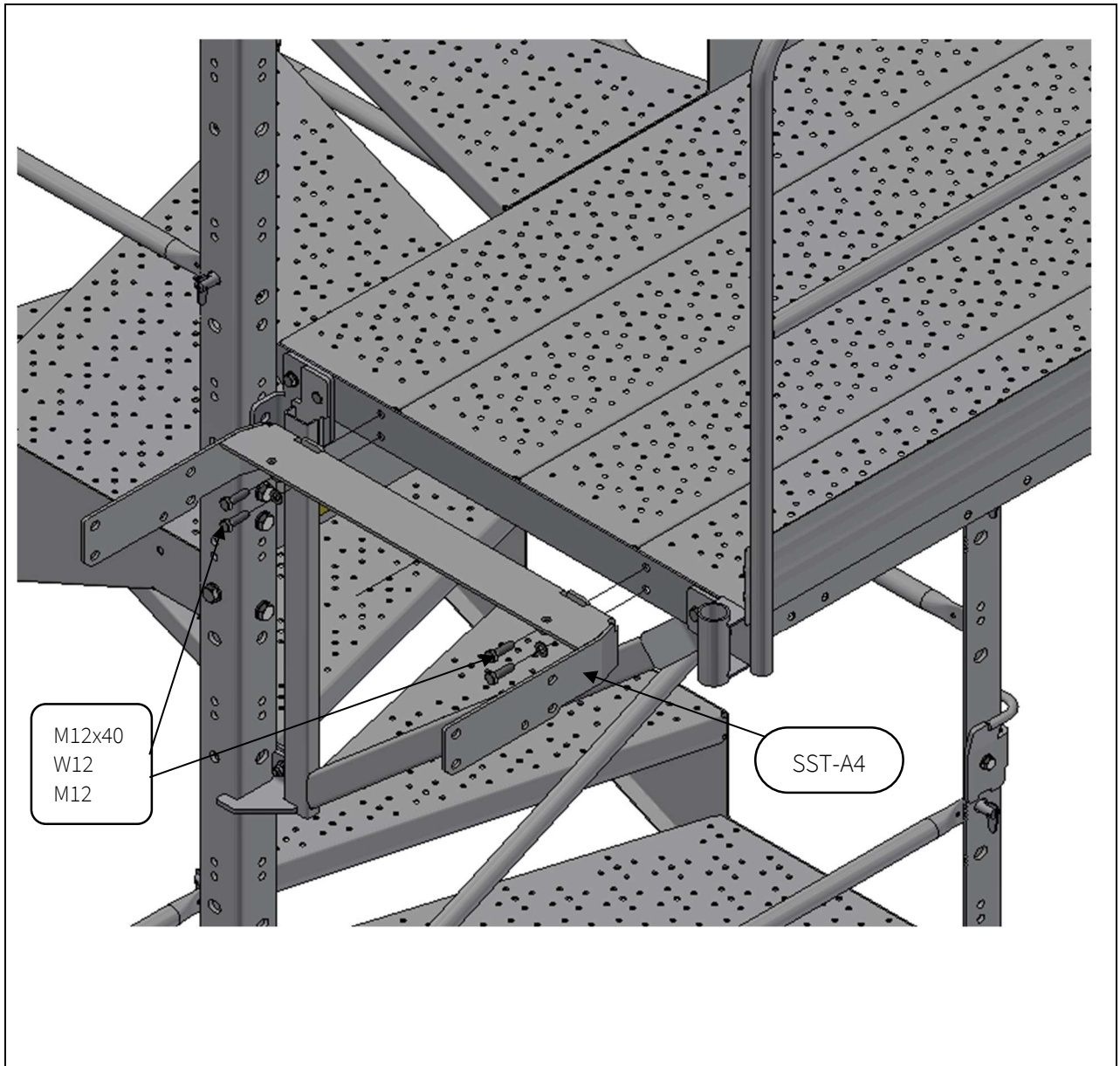

To install the TAS downward stairs, remove the top feet and then use the same screws to screw them to the console SST-A4.

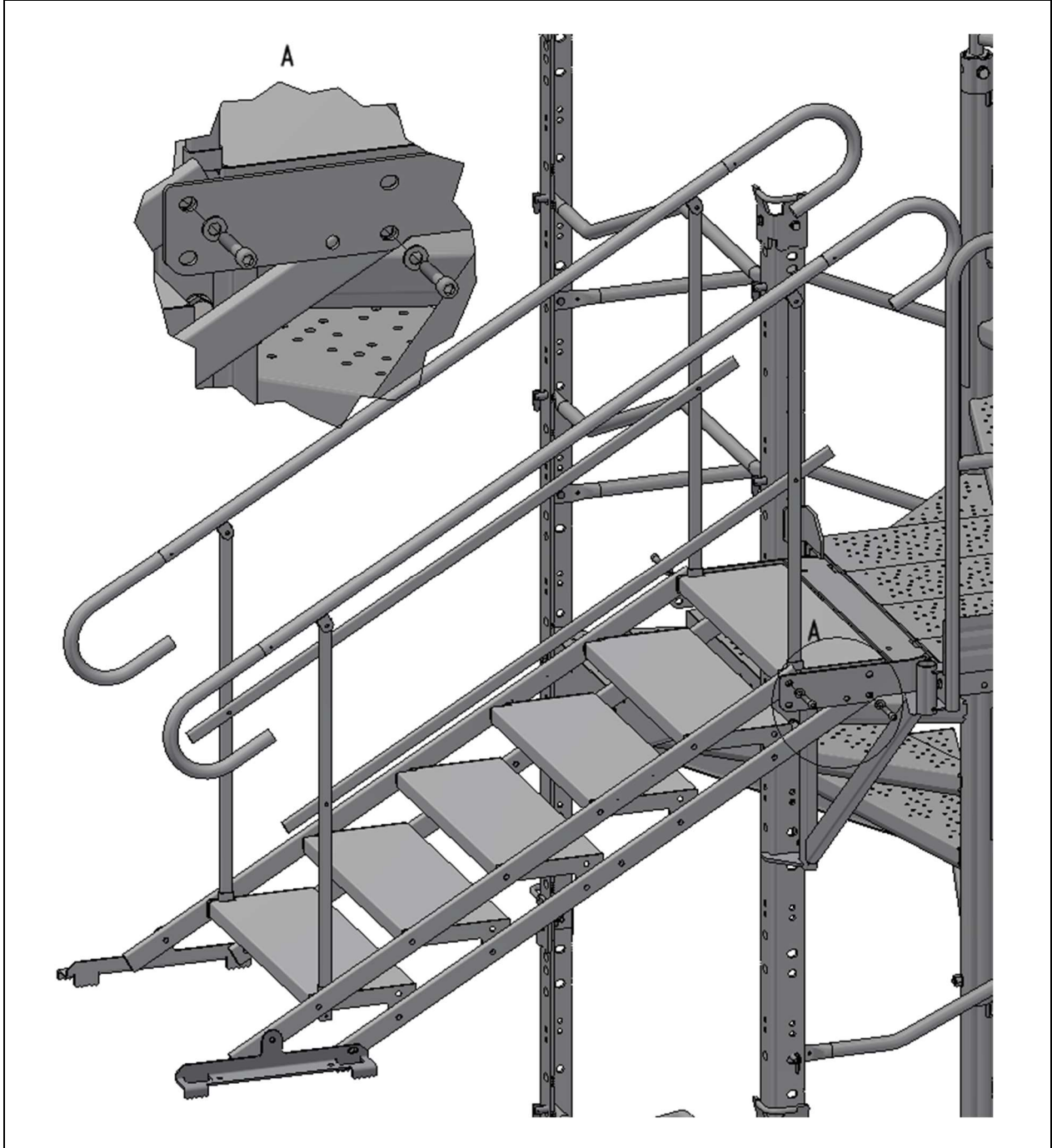



To install the TAS upward stairs, install an additional step SST-E2 on the console SST-A4. Then, remove the top feet from the TAS stairs and screw the stairs using the same screws.

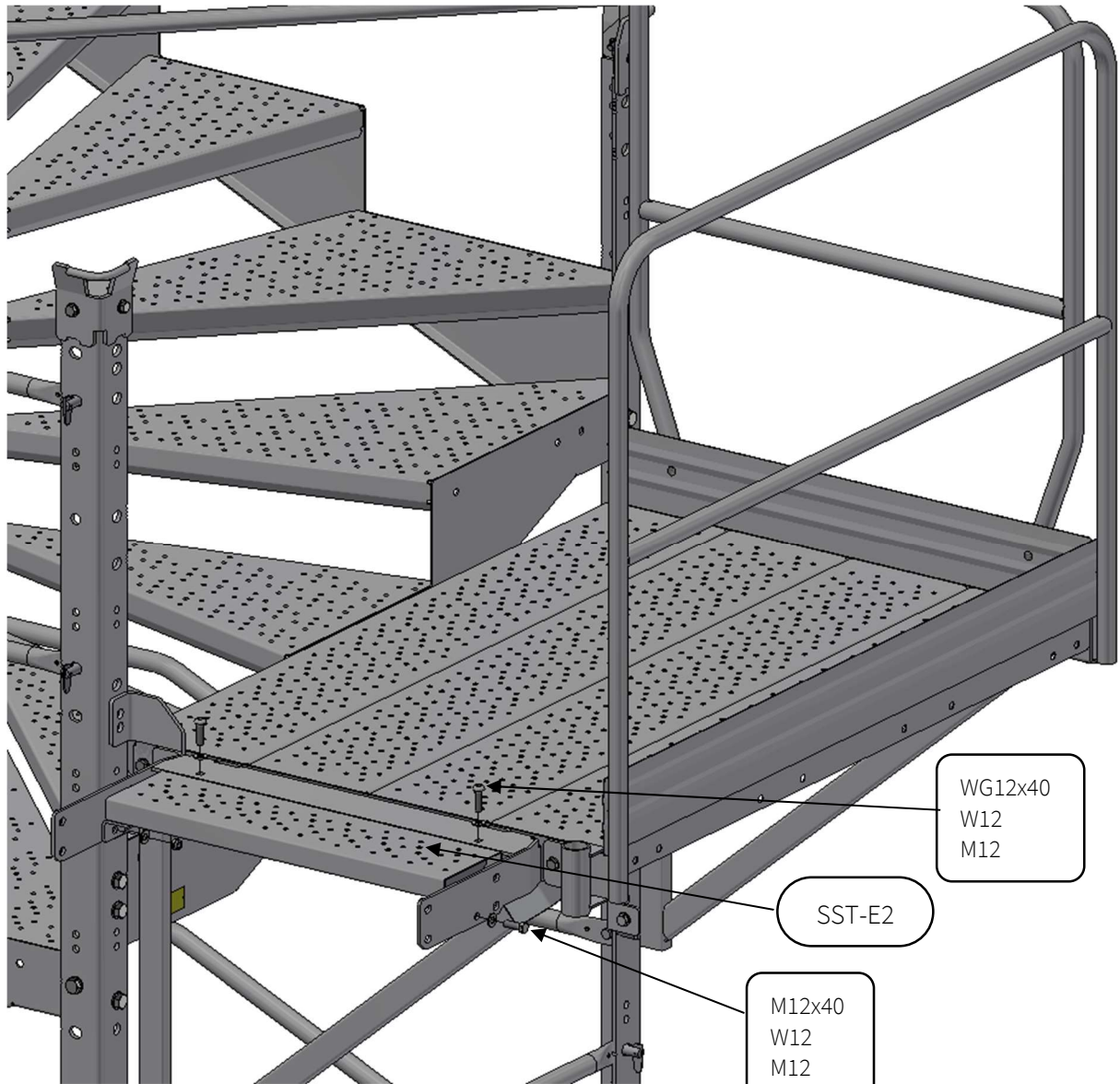

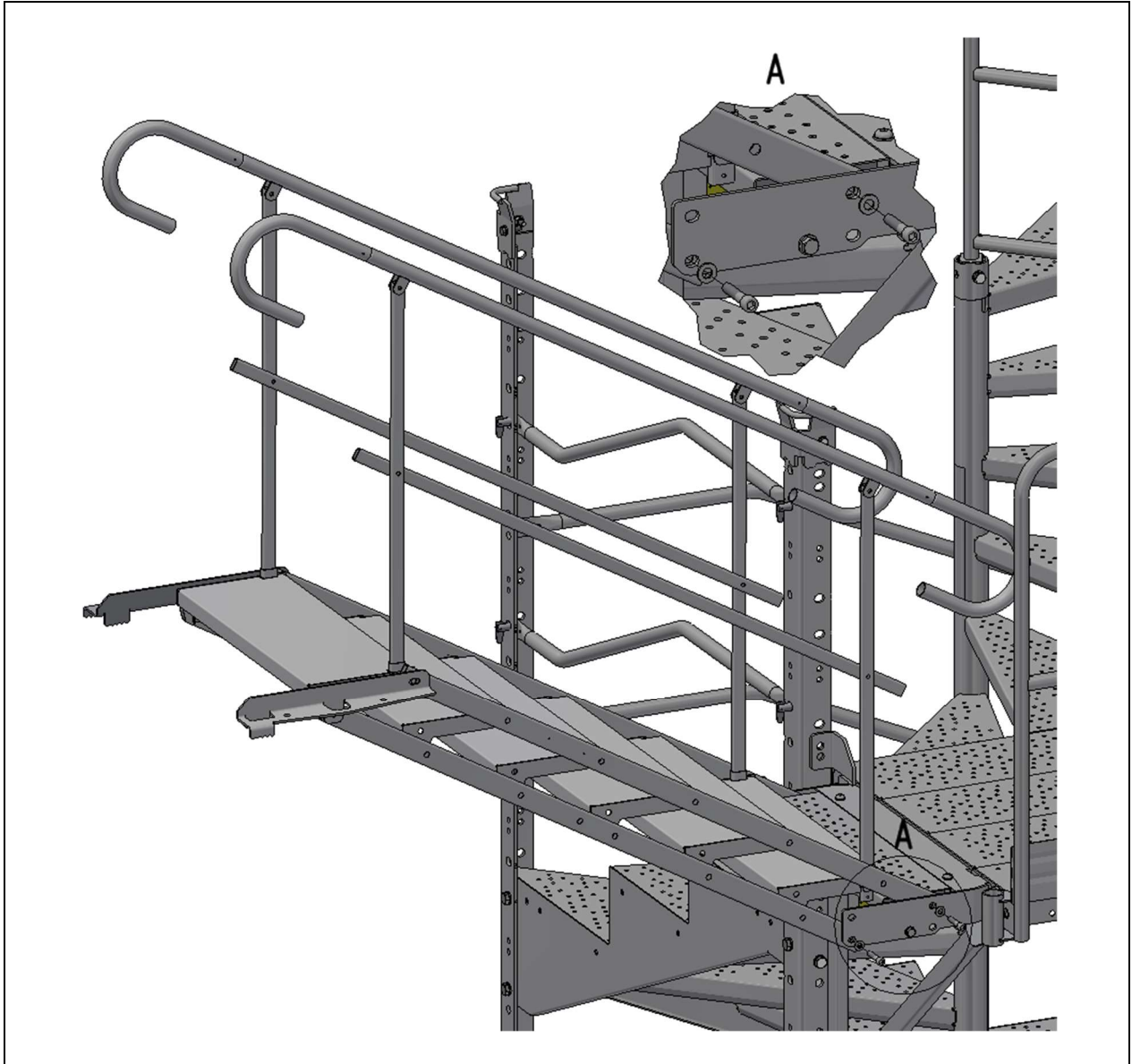

6.17. Installation of the TAS straight descent

The straight descent may only be installed on the central step of the given side of the SST staircase.

To install the TAS downward stairs, install the console SST-A4. Next, remove the top steps of the TAS stairs and screw them to the console using the same screws.

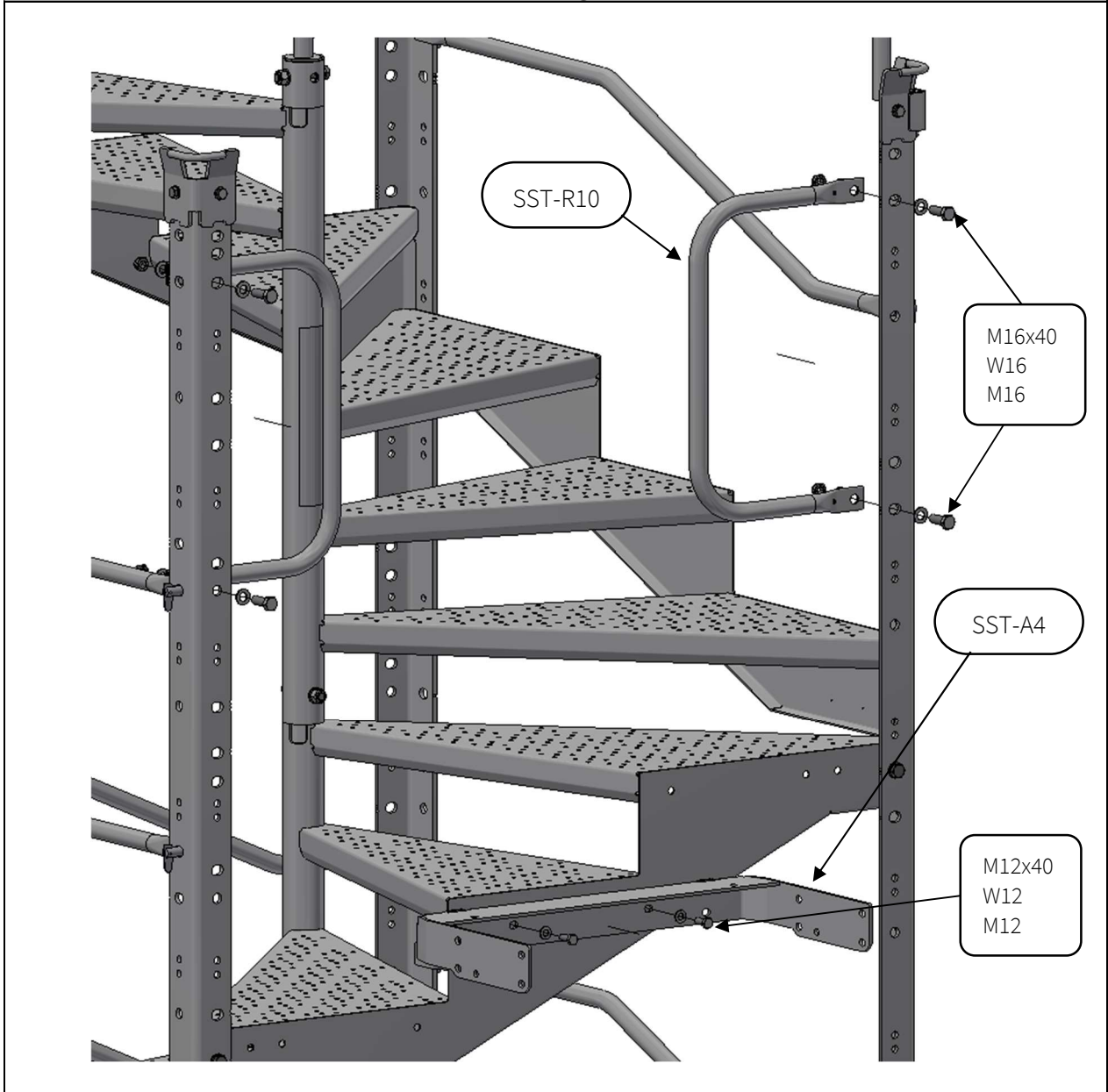

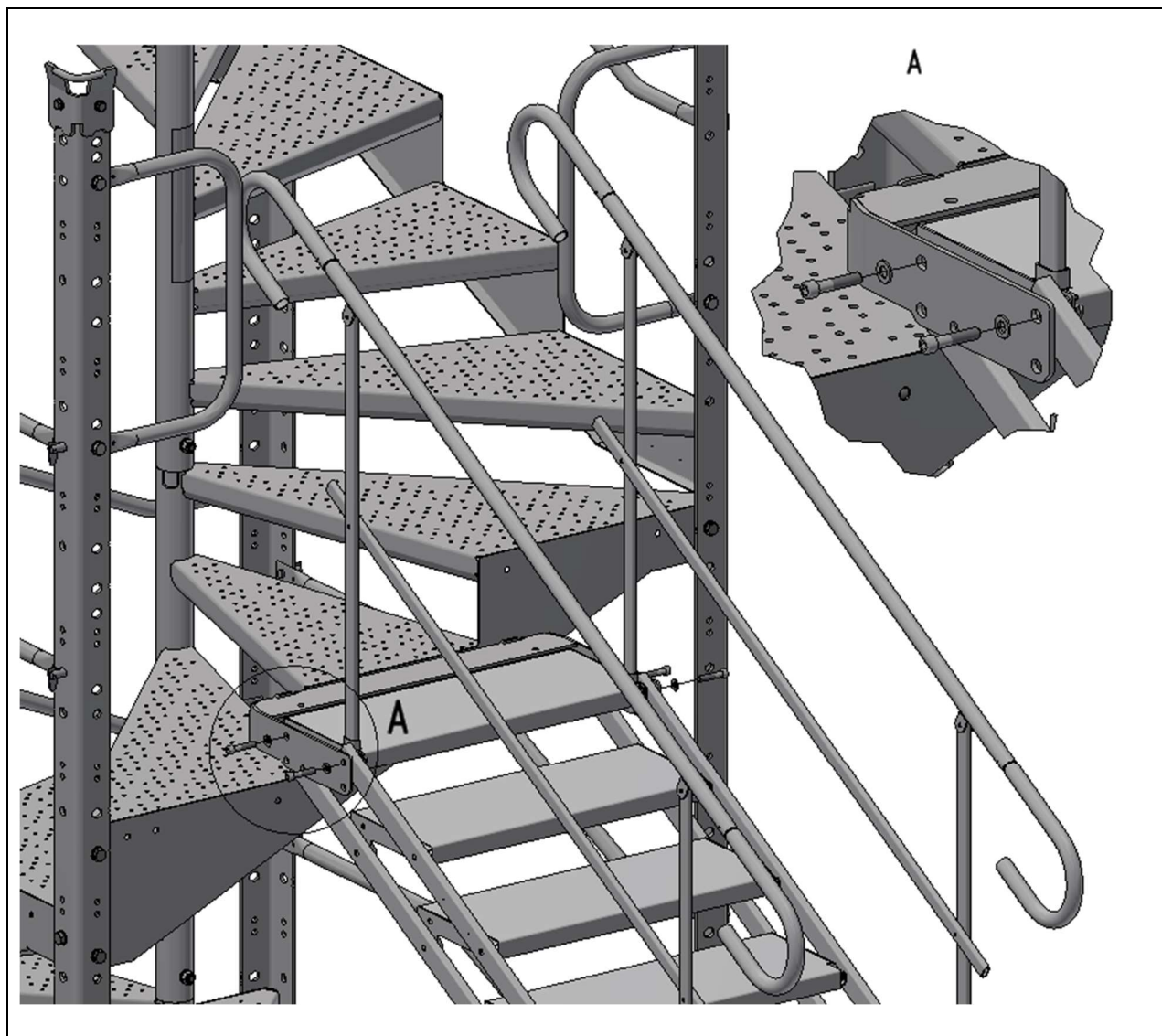



To install the TAS upward stairs, install an additional step SST-E2 on the console SST-A4. Then, remove the top feet from the TAS stairs and screw the stairs using the same screws.

