TLC CONTAINER STAIRS

Levelled Version 3

Assembly and Operation Manual



Piotr Abram

(Prepared)

Piotr Garwol

(Checked)

Łukasz Osikowicz

(Approved)

Table of Revisions

No.	FULL NAME	SECTION	DATE OF REVISION	SCOPE OF REVISION	NOTES
1	Piotr Abram	KT	27.01.2017	Footer, Header	
2					
3					
4					
5					
6					
7					
8					
9					
10					
11					
12					
13					
14					
15					

Table of Contents

1.	<i>Introduction</i>	5
1.1	Intended use	6
1.2	Unintended use.....	6
1.3	Standards and materials.....	6
1.4	Terms and definitions	6
2.	<i>List of components</i>	6
3.	<i>Parameters and drawings of the components</i>	7
4.	<i>List of needed tools and materials</i>	11
5.	<i>Mounting the stairs</i>	11
5.1	Working with the container set.....	11
5.2	Ground preparation	14
6.	<i>Assembly</i>	14
6.1	Mounting the flights of stairs and supports.	14
6.2	Preparation of anchors and columns.....	15
6.3	Mounting the flight of stairs I.....	18
6.4	Mounting the flight of stairs II	20
6.5	Mounting the flight of stairs III.....	21
6.6	Mounting the platform grates.	22
6.7	Mounting the railings	24
6.8	Mounting the toe-boards	29
6.9	Mounting the railing brackets.....	30
6.10	Mounting the plugs	31
6.11	Connecting the stairs and the container set	31
7	<i>Adjustment and settings</i>	32
8	<i>Labelling</i>	33
9	<i>Operation</i>	33
9.1	Safety rules.....	33
9.2	Manufacturer's recommendations.....	34
10	<i>Protection</i>	34
11	<i>Inspection and Maintenance</i>	34
12	<i>Disassembly</i>	34
13	<i>Replacing damaged components</i>	35
13.1	Replacing the step	35
13.2	Replacing the platform.....	35
13.3	Replacing the railings.....	35
14	<i>Troubleshooting</i>	35
15	<i>Disposal</i>	36

GENERAL SAFETY RULES

1. Before the start of assembly and operation please read this manual. Improper assembly or operation may cause danger to health or life.
2. Due to the large size and weight of the individual components, you must take special care during transport, assembly and operation of the stairs.
3. Materials such as plastic, polystyrene, included in the product or its packaging, constitute a potential danger and must be kept out of reach of children.
4. Keep this manual as a source of information for users of the stairs, and for its maintenance service.
5. Assembly or operation of the stairs inconsistent with this manual may adversely affect the product and/or be a source of danger.
6. The manufacturer is not responsible for any damage caused by improper assembly of the product or its unintended use.
7. It is not allowed to make any modifications in the construction of components of the stairs.
8. The stairs are designed for use in industrial environments, i.e. for use by adults, following health and safety provisions, trained and not under the influence of alcohol.
9. Pay special attention when staying under the stairs at a time when they are used by others due the possibility of falling objects that can penetrate through the grates of the platform.
10. It is not allowed to let the stairs be simultaneously used by the number of people having a larger total mass than the permissible load of the stairs.
11. The stairs are used for people moving in order to reach the lower levels of deep excavations and in the opposite direction. Staying on the steps as well as placing in these places objects that are not components of the stairs is inconsistent with the principles of operation.
12. Do not use the stairs to transport objects other than equipment of containers.
13. It is forbidden to use the stairs by people without proper footwear. This applies, in particular, to high heels, which can get stuck in the platform grates.
- 14.

This manual was prepared by TLC Sp. z o. o. and is its property. TLC has all the copyright resulting therefrom.

Without the written consent of TLC Sp. z o. o. it is forbidden to give manual to others in whole or in part, to copy and distribute it in whole or in part, to process it in electronic form in whole or in part. The manufacturer reserves the right to make changes to the product without notifying the user.

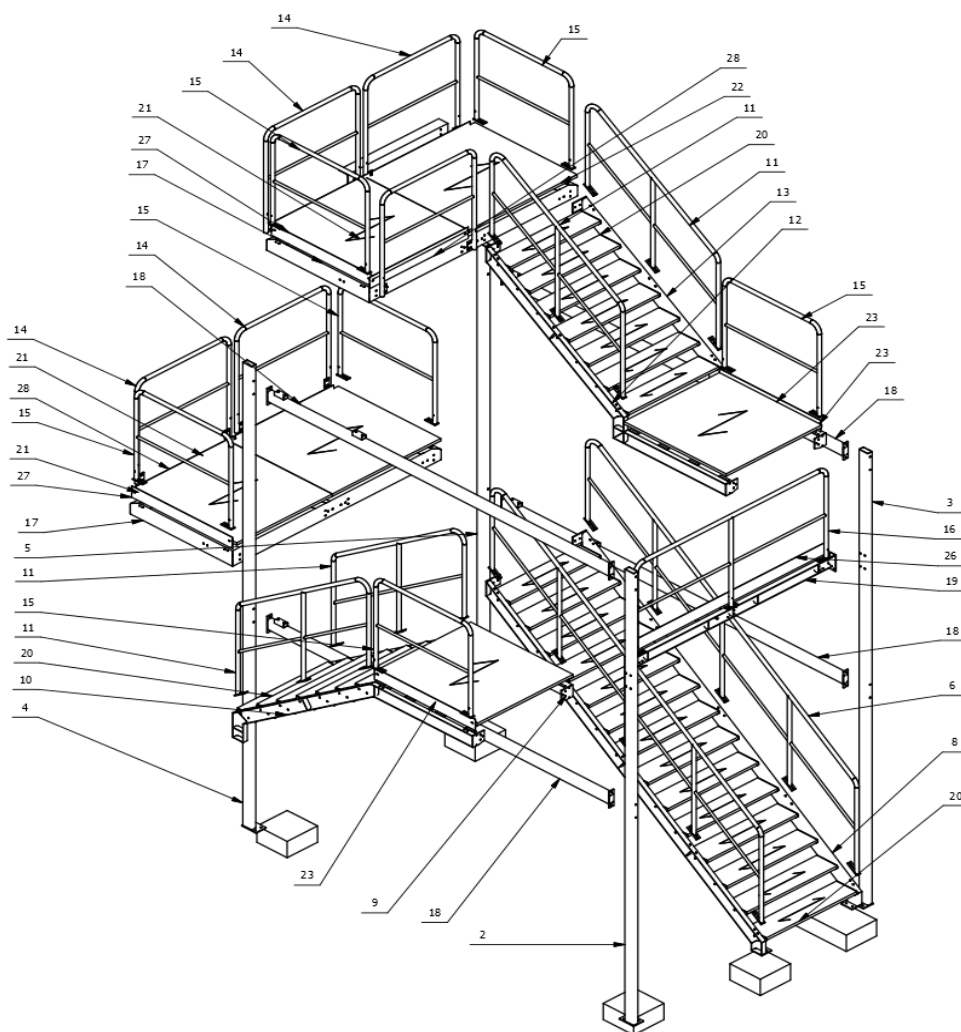

Fig.1. Container stairs – general view

(all figures included in this manual present platform and step grates simplified, i.e. as smooth surfaces)

1. Introduction

The subject of this manual is the technical description, assembly description and operation description of the container stairs for moving of the people using container systems. The stairs are assembled after prior setting of the containers, in front of which there must be provided adequate space and ground with sufficient capacity. Essential elements of the stairs are side beams that are connected using the steps to constitute flights of stairs. The side beams are equipped with railings that are connected to them permanently or screwed using bolts. The flights of stairs are connected with front beams in the form of sections of the profile. These beams also serve as an interface between the columns. The railings protecting the space where people move are screwed to the front beams people. At different levels and on platforms there are platform grates, and between the side beams, as already mentioned, there are steps. Both platforms and steps are filled with 30x3 flat bars and rods, forming 34x38 meshes. The stairs equipped with toe-boards in the form of profiled sheets with the task of sealing areas of the platforms. The whole is mounted on 4 pillars creating an independent and self-supporting structure. The container stairs system was designed in a manner making possible a multi-variant development (Section 5.1) and, after use, an easy disassemble and transport together with containers to the next place of use.

1.1 Intended use

This container stairs are intended for use in mobile container systems for offices, warehouses and social facilities in the industry, on construction sites and in all kinds of three storey temporary installations.

Intended use also includes:

- compliance with all instructions contained in this manual,
- carrying out regular inspections of the stairs.

1.2 Unintended use

Use of the product inconsistent with the instructions – and therefore any deviation from the instructions given in this manual – is considered to be unintended use.

1.3 Standards and materials

During the design, the guidelines of the following standards were taken into account:

PN-EN 1990 2004 AC2010; PN-EN 1991-1-1 2004 Ap1 2010; PN-EN 1991-1-3 2005 Ap1 2010; PN-EN 1991-1-4 2008 p2 2010; PN-EN 1991-1-6 2007 Ap1 2010; PN-EN 1991-1-7 2008 Ap1 2010; PN-EN 1993-1-(1-12).

For building the stairs there were used construction materials such as channel sections, try squares, flat bars, tubes and rods with appropriate parameters to ensure safe operation and long life. In order to protect against corrosion the whole was protected with anti-corrosion coating.

1.4 Terms and definitions



Information!

Sign indicating important information



Warning!

Sign indicating attention



Danger!

Sign indicating a danger or information vital to safety



Crane

Sign indicating the need for using a crane

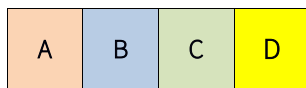

Development variants

Sign indicating, to which variant the description applies

2. List of components

Supplied complete set of stairs container should contain the components according to the following table:



Tab. 1. List of stair parts depending on the variant

Item	Name of the element	Symbol or Standard	Number of pieces			
			Variant A	Variant B	Variant C	Variant D
7.	Left side beam	F-01	1			
8.	Right side beam	F-02	1			
10.	Left side beam	F-03	1			
9.	Right side beam	F-04	1			
12.	Left side beam	F-05	1			
13.	Right side beam	F-06	1			
18.	Beam 1	B-01	4			
19.	Beam 2	B-02	1			
17.	Platform	M-02	1			
11.	Railing 1	R-01	4			
6.	Railing 2	R-02	2			
15.	Railing 4	R-04	4		2	6
26.	Railing 5	R-05	1			
14.	Railing 8	R-08	5			1
2.	Column 1	S-01	1			
5.	Column 2	S-02	1			
4.	Column 3	S-03	1			
3.	Column 4	S-04	1			
21.	Grate 1	G-01	2			
23.	Grate 2	G-02	2			
22.	Grate 3	G-03	2			
28.	Toe-board K-03	Bt-140x1295	5			1
26.	Toe-board K-04	Bt-140x2590	1			
27.	Toe-board K-06	Bt-140x1330	4		2	6
	Tube clamp $\phi 42$	-	9	8		
	Universal bracket for mounting grates	-	24			
	Plug 120x60	-	4			
	Connector 2	A-02	1		2	0
	Connector 3	A-03	1		2	0
	Support	A-4	0			4
	Bolt M12x150 8.8 A2C	PN-85/M-82101	16			
	Bolt M12x90 8.8 A2C	PN-85/M-82101	8			
	Bolt M12x40 8.8 A2C	ISO 4017	122	114		
	Bolt M12x30 8.8 A2C	ISO 4017	112			
	Bolt M6x40 8.8 A2C	ISO 4017	21	17		
	Foundation bolt (Anchor) M12	-	16			
	Nut M12	ISO 4032	258	250		
	Washer 12		370	362		
	Washer 6		21	17		
	Spring washer 12.2	PN-77/M-82008	146	138		

3. Parameters and drawings of the components

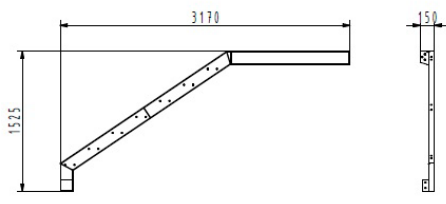
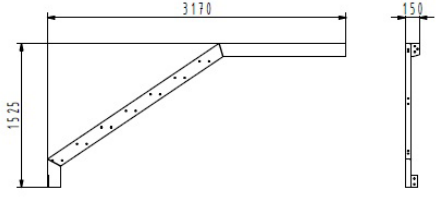
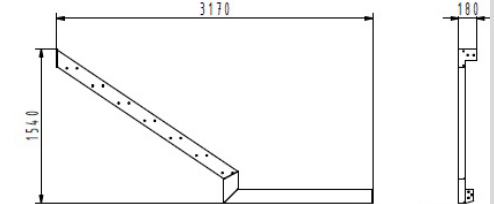
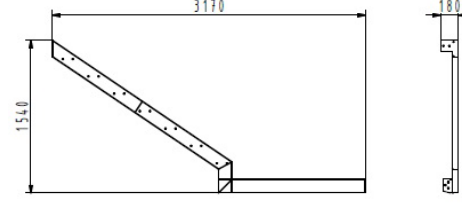
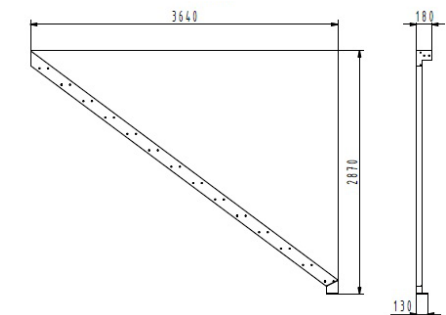
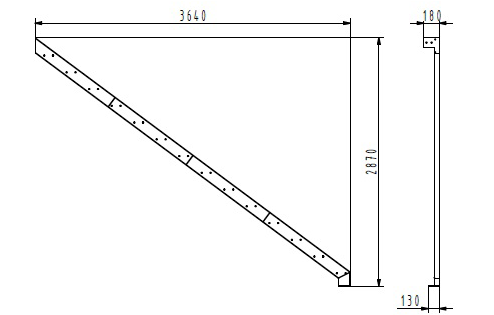
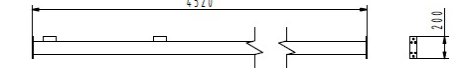
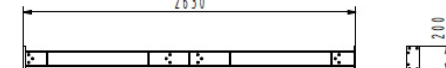
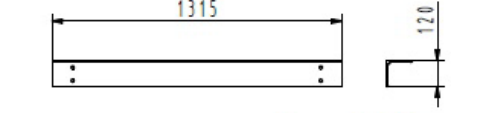
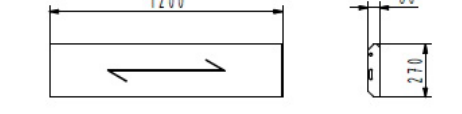
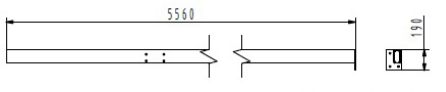
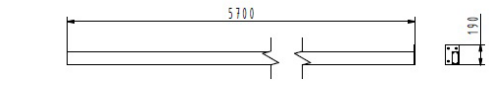
Tab. 2. The main components of the stairs with dimensions and weights

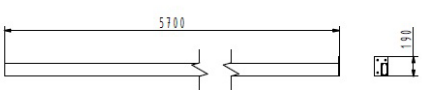
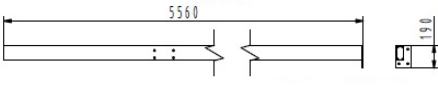
<p>F-01</p>  <p>Weight = 38.785kg</p>	<p>F-02</p>  <p>Weight = 28.785kg</p>	<p>F-03</p>  <p>Weight = 39.688kg</p>
<p>F-04</p>  <p>Weight = 39.688kg</p>	<p>F-05</p>  <p>Weight = 47.169kg</p>	<p>F-06</p>  <p>Weight = 47.169kg</p>
<p>B-01</p>  <p>Weight = 61.952kg</p>	<p>B-02</p>  <p>Weight = 35.748kg</p>	<p>A-01</p>  <p>Weight = 3.042kg</p>
<p>E-01</p>  <p>Weight = 6.710kg</p>	<p>S-01</p>  <p>Weight = 74.766kg</p>	<p>S-02</p>  <p>Weight = 74.766kg</p>

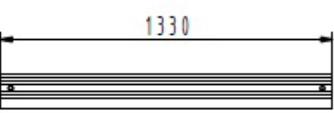
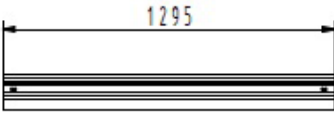
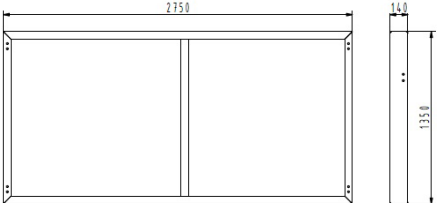
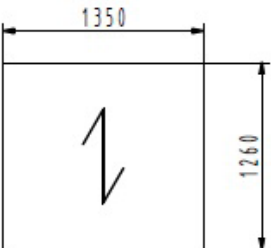
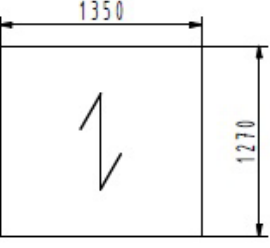
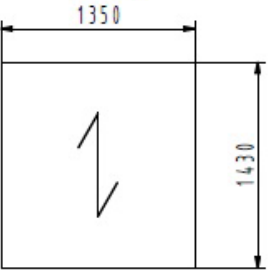
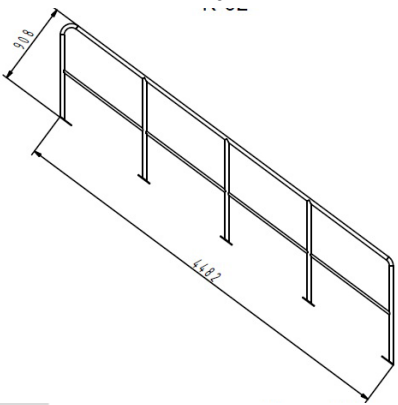
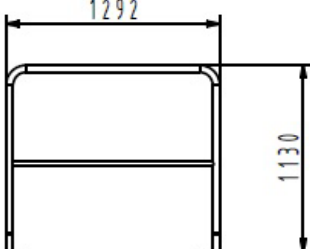
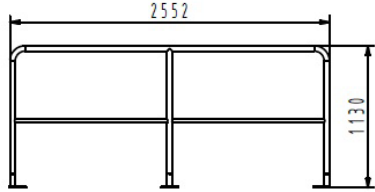
<p>S-03</p>  <p>Weight = 74.766kg</p>	<p>S-04</p>  <p>Weight = 74.766kg</p>	<p>K-04 Bt-140x2590</p>  <p>Weight = 4.426kg</p>
<p>K-06 Bt-140x1330</p>  <p>Weight = 2.272kg</p>	<p>K-03 Bt-140x1295</p>  <p>Weight = 2.212kg</p>	<p>M-02</p>  <p>Weight = 88.638kg</p>
<p>G-01</p>  <p>Weight = 31.843kg</p>	<p>G-02</p>  <p>Weight = 32.095kg</p>	<p>G-03</p>  <p>Weight = 36.139kg</p>
<p>R-02</p>  <p>Weight = 32.753kg</p>	<p>R-04</p>  <p>Weight = 11.04kg</p>	<p>R-05</p>  <p>Weight = 19.114kg</p>

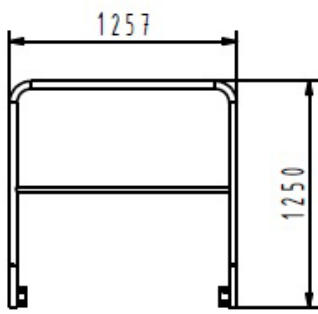
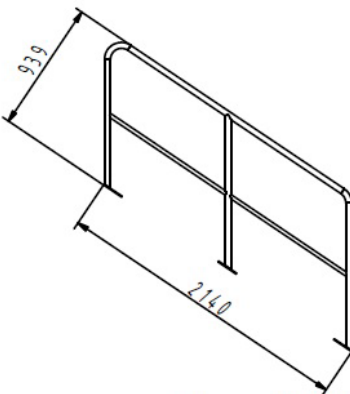
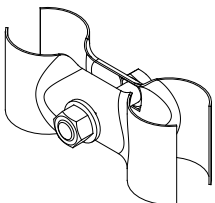
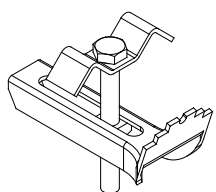
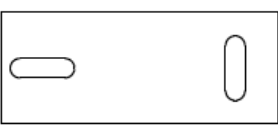
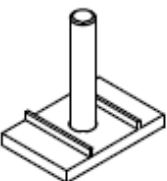
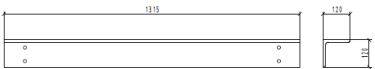
<p>R-08</p>  <p>Weight = 11.636kg</p>	<p>R-01</p>  <p>Weight = 17.318kg</p>	<p>Tube clamp ϕ 42</p>  <p>Weight = 0.2kg</p>
<p>Universal bracket for mounting grates</p>  <p>Weight = 0.15kg</p>	<p>A-02</p>  <p>Weight= 0.939kg</p>	<p>A-03</p>  <p>Weight = 0.045kg</p>
<p>Support A-4</p>  <p>Weight= 3.044kg</p>		

4. List of needed tools and materials

To complete the foundation and the assembly of the stairs, the following should be prepared:

- Class B25 concrete or concrete blocks with minimum dimensions (L x W x H) of 500x500x150mm. Assembly on the reinforced concrete panels is allowed.
- Construction tools, i.e.: shovel, level, pencil, measuring tape,
- Locksmith tools, wrenches: 17, 19 and 24,
- Jackhammer and concrete drill Ø18, metal drill Ø12, 14, 16,
- Capper for hex sheet metal screws 10,
- Crane with a capacity of min. 1000kg and a lifting height of ~7m,
- Mounting ladder,

5. Mounting the stairs

5.1 Working with the container set

Design of the stairs allows access to stacked containers in the number of three pieces. There are 3 variants of possible arrangements of the stairs in relation to the container set (**Fig. 4**):

- VARIANT A – entrance onto the stairs and the flight of stairs on the right side
- VARIANT B – entrance onto the stairs and the flight of stairs on the left side
- VARIANT C – arrangement of the container stairs between two container sets
- VARIANT D – arrangement of the container stairs to the front of containers

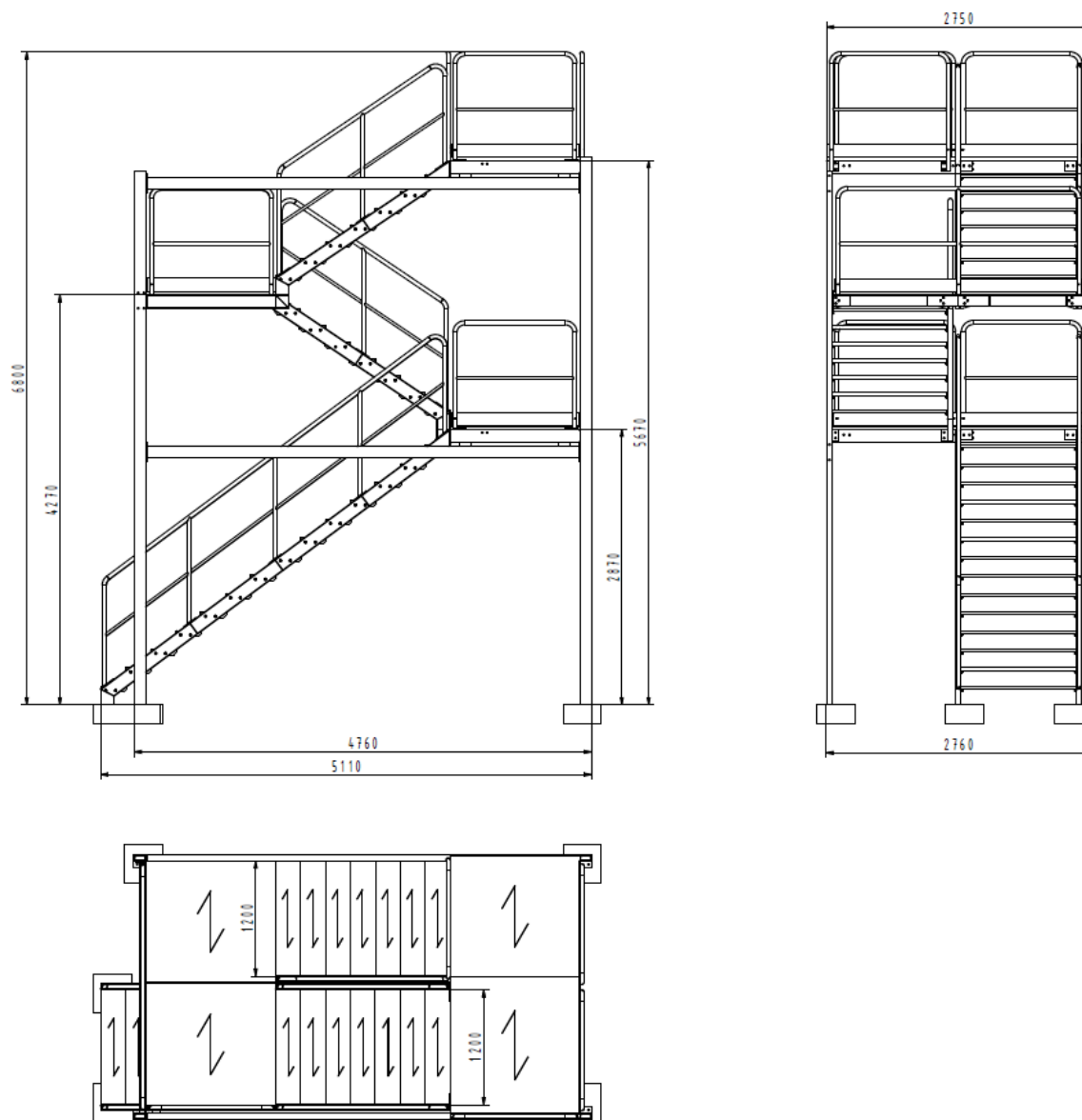
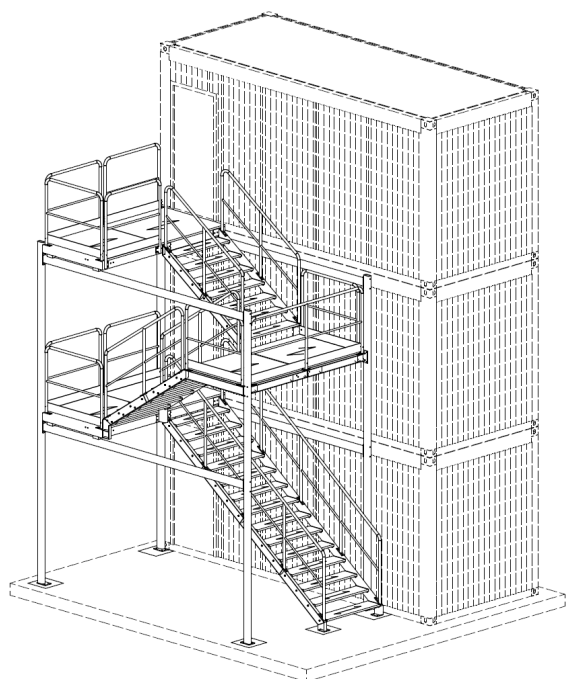
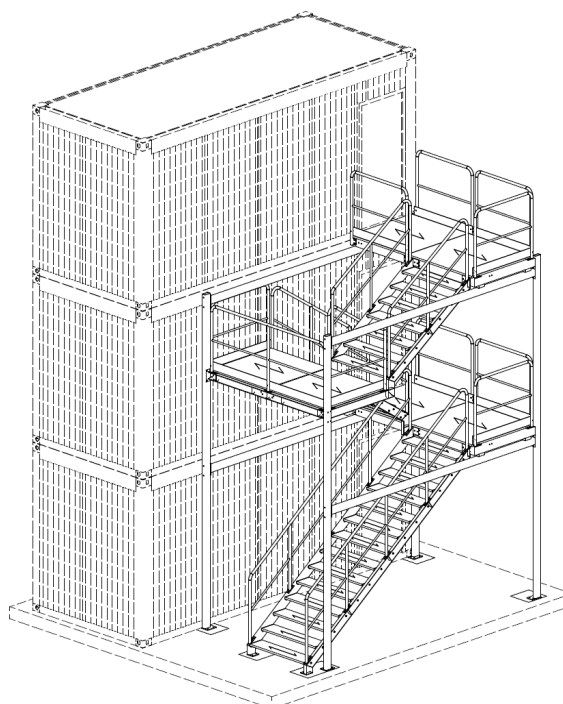

Fig. 3. Dimensions

Variant A



Variant B



Variant C

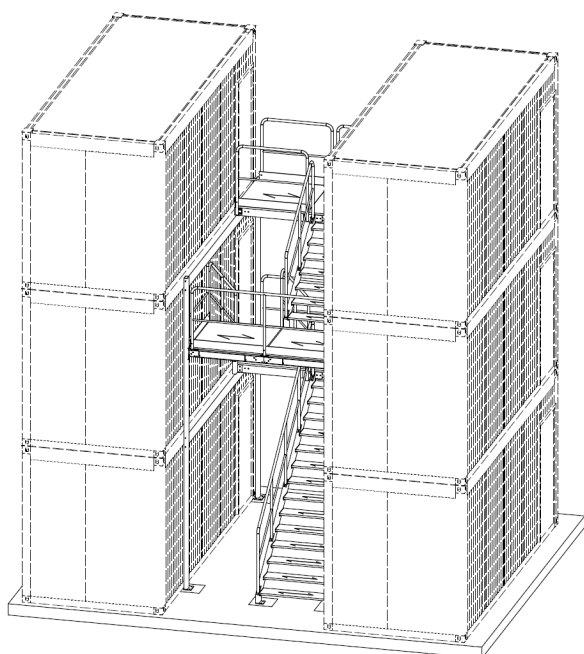

Variant D

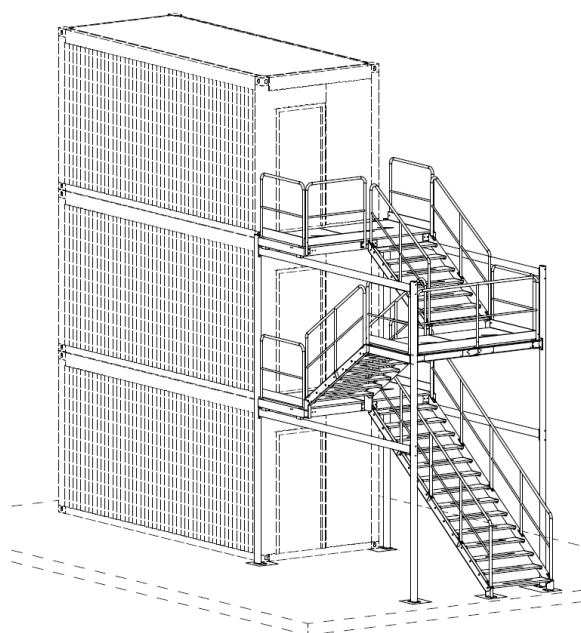

Fig. 4. Variants of arrangement of the stairs in relation to the container set

The container set must be assembled according to the assembly manual attached to the container or outsourced to specialists.

Properly assembled container stairs should remain in a stable position in a distance ensuring safe movement from the platforms to the inside of the container.

5.2 Ground preparation

To ensure proper assembly and operation, the container stairs must be assembled on a concrete base levelled at an area corresponding to the dimensions of the stairs shown in **Fig. 3**. Due to its temporary destination, the assembly on reinforced concrete panels or concrete blocks with minimum dimensions (L x W x H) of 500x500x150mm is allowed. In the case of using blocks, prerequisite for this is that their upper surfaces were all in one plane and the blocks themselves were embedded in a hardened gravel ground having an effective drainage system, in a safe and stable manner.

6. Assembly

Before assembling the components of the stairs, you need to learn the details of this manual, especially those activities that require the use of a crane, in order to be able to effectively use the equipment rental time.

6.1 Mounting the flights of stairs and supports.

It refers to the variant:

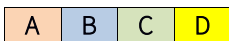

Flights of stairs are mounted from side beams and steps using bolts M12x30, nuts M12 and washers Ø12.2. This manual describes the stairs composed of three flights of stairs to be mounted at the beginning of the assembly.



Flights of stairs must be mounted as close as possible to containers taking into account a range of a crane.

At this stage, it is worth to skip mounting screwed railings due to unnecessary increase in overall dimension and thus the difficulty of manoeuvring the flight of stairs during the assembly with the use of a crane.

Flight of stairs I. Arrange the beams **F-05** and **F-06** next to each other at a distance of approx. 1.2m. Between the beams, mount steps, starting with the first and last, and then inserting the others.



During the assembly of initial and subsequent steps, do not tighten the bolts using a maximum torque. This should be done after inserting all steps.

Flight of stairs II. Arrange the beams **F-01** and **F-02**, as in the case of the flight of stairs I.

Flight of stairs III. Arrange the beams **F-03** and **F-04**, as in the case of the flight of stairs I.

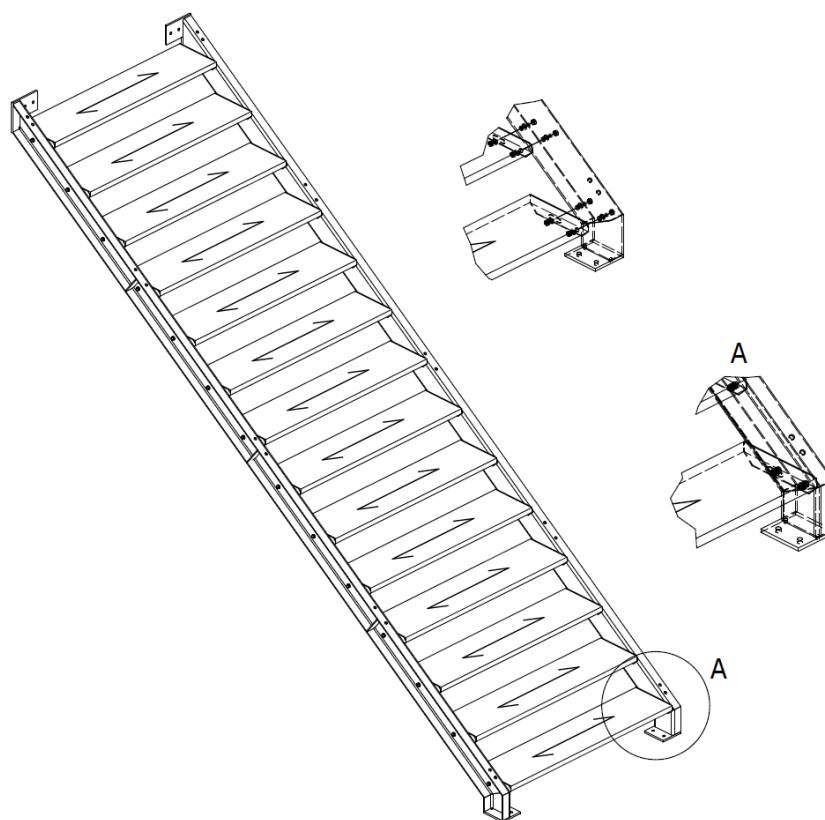

Fig. 5. Mounting the steps to the side beams

6.2 Preparation of anchors and columns

It refers to the variant:

A	B	C	D
---	---	---	---

- Scribe the holes for mounting anchors according to the diagram in Fig. 6.

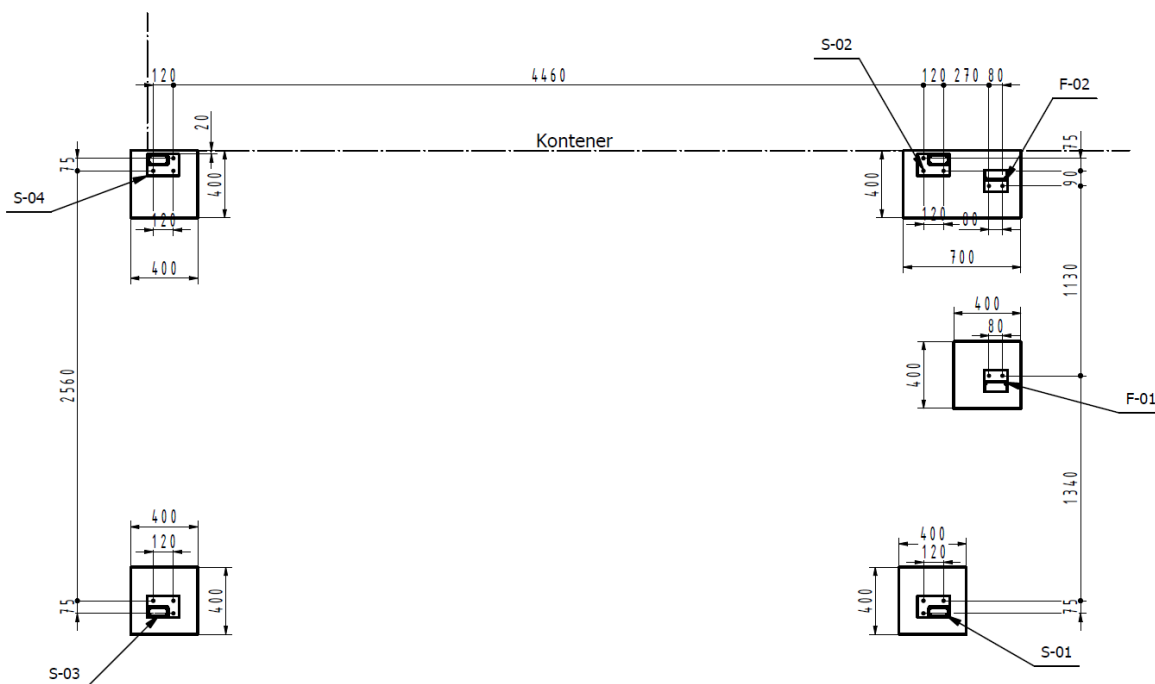

Fig. 6. Schematic arrangement of holes for anchors

- Drill and clean the holes.
- Mount anchors and leave for at least 1 hour to cure the adhesive.



The axes of the anchors should be positioned vertically and according to the dimensions. The anchors should protrude approximately 30mm above the surface of the foundation.

- **Support I.** Connect the columns **S-01** and **S-03** with the beams **B-01** using bolts M12x150, nuts M12 and washers Ø12.2.

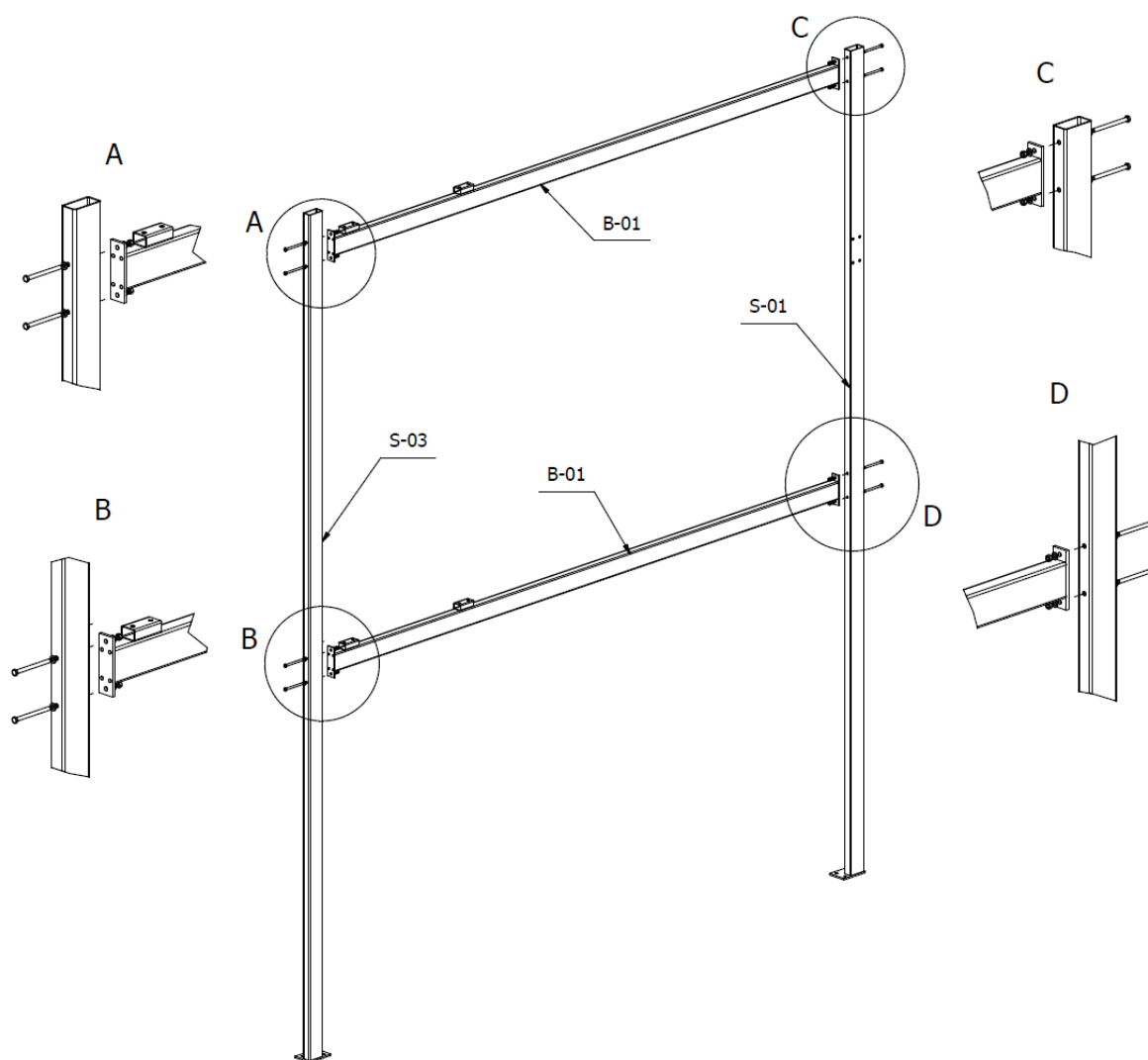
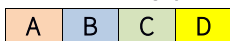

Fig. 7. Mounting the beams B1 to the columns S-01 and S-03

Support II. Arrange the columns S-02 and S-04 and the beams B-01, as in the case of the support I.

It refers to the variant:



- Embed the **supports I and II** on the foundations and fasten them using nuts M12 and washers Ø12.2.
- Mount the platform **M-02** using bolts M12x30, nuts M12 and washers Ø12.2.

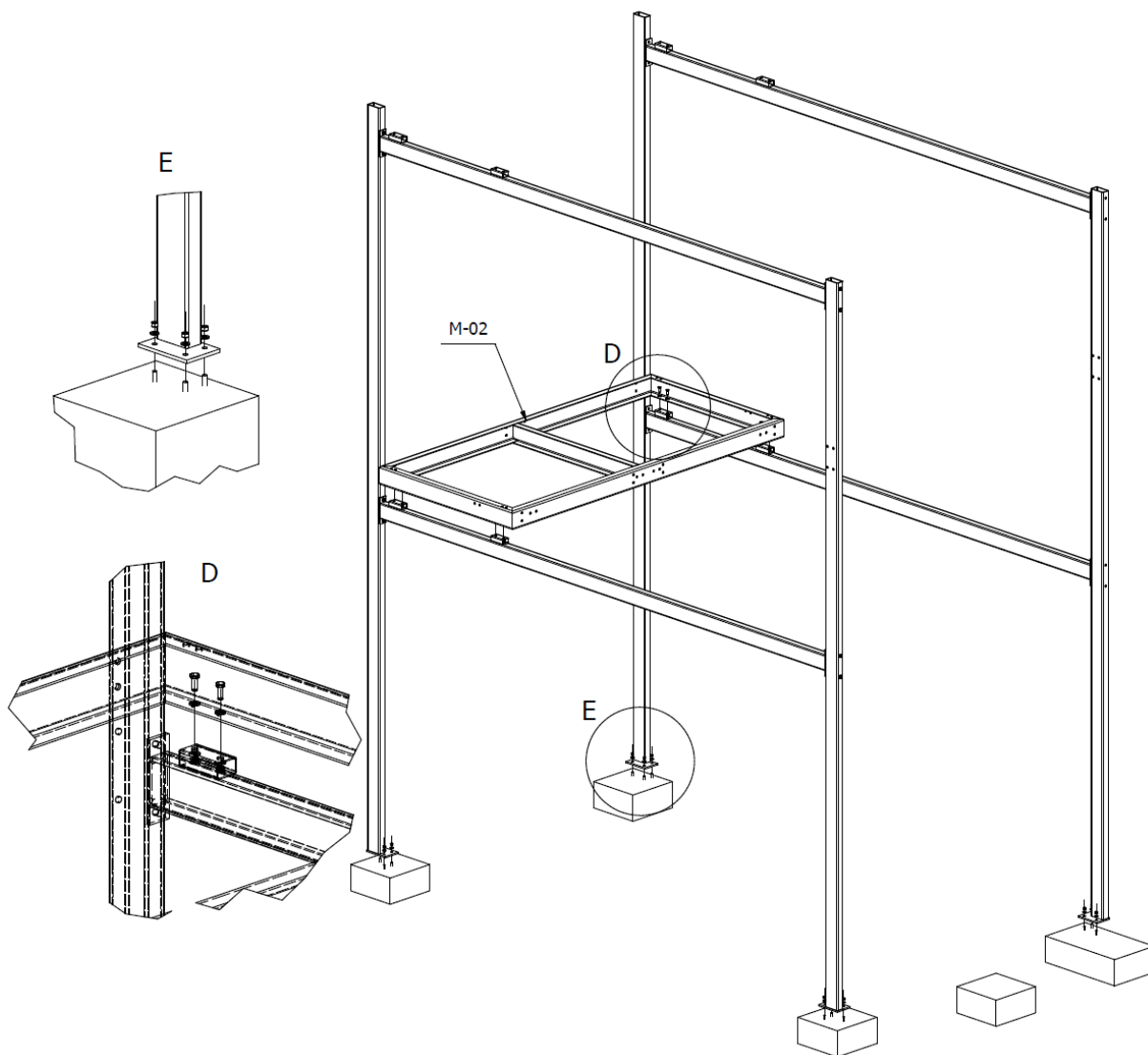
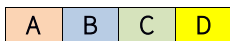

Fig. 8. Mounting the platform M-02 of the beams.

6.3 Mounting the flight of stairs I

It refers to the variant:



- Fasten the **flight of stairs I** to the platform M-02 using bolts M12x30, nuts M12, washers Ø12.2, as well as to the foundation pedestal using nuts M12 and washers Ø12.2.

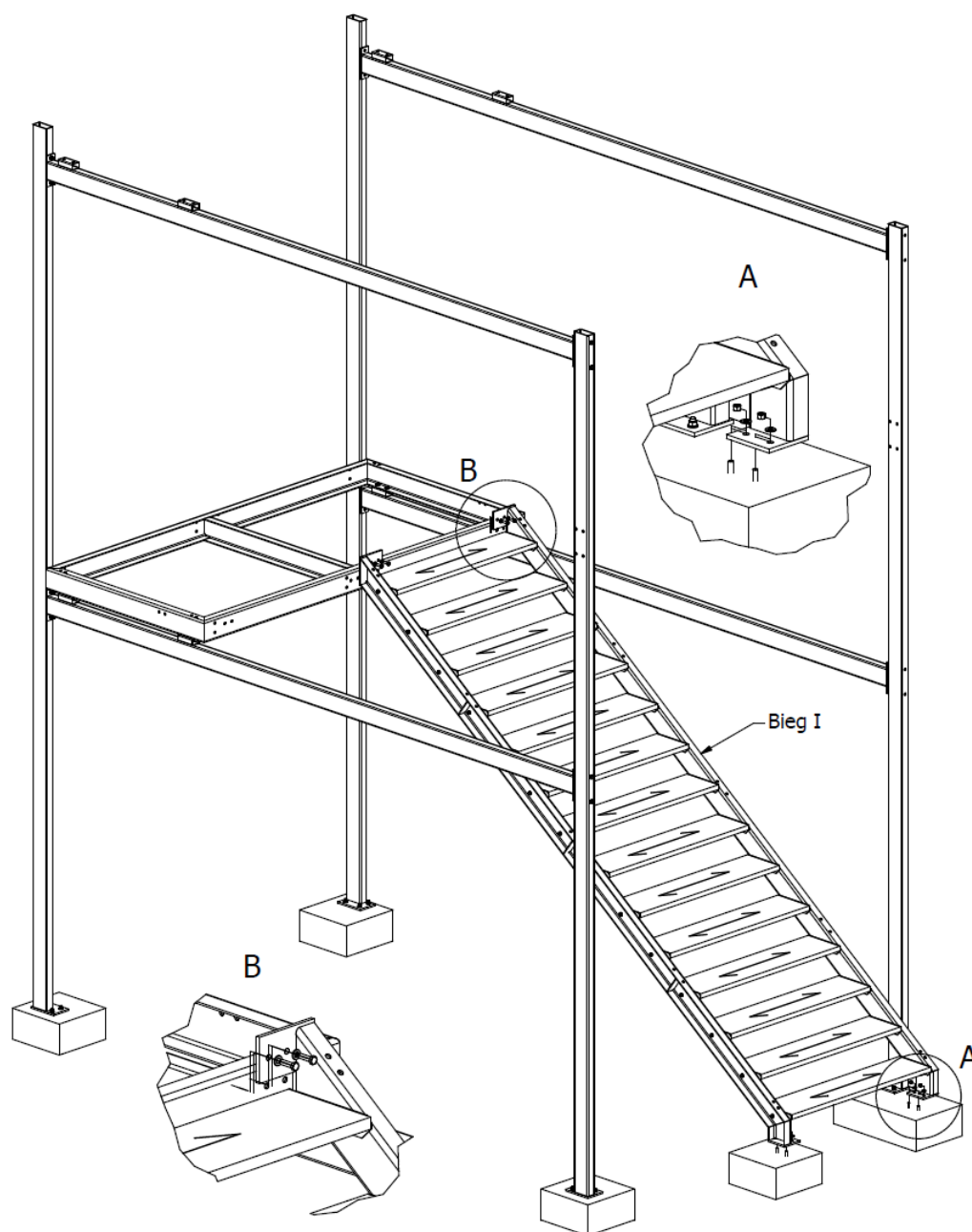

Fig. 8. Mounting the flight of stairs I

- Using a crane put the **flight of stairs I** on the support with one end, while with another end on a concrete ground.
- Fasten the **flight of stairs I** using 4 bolts M12x30 screws, nuts M12 and washers Ø12.2 to the platform M-02.
- Anchor the **flight of stairs I** by tightening nuts M12 and washers Ø12.2.
- Fasten the **beam B-02** using bolts M12x90, nuts M12, washers Ø12.2.

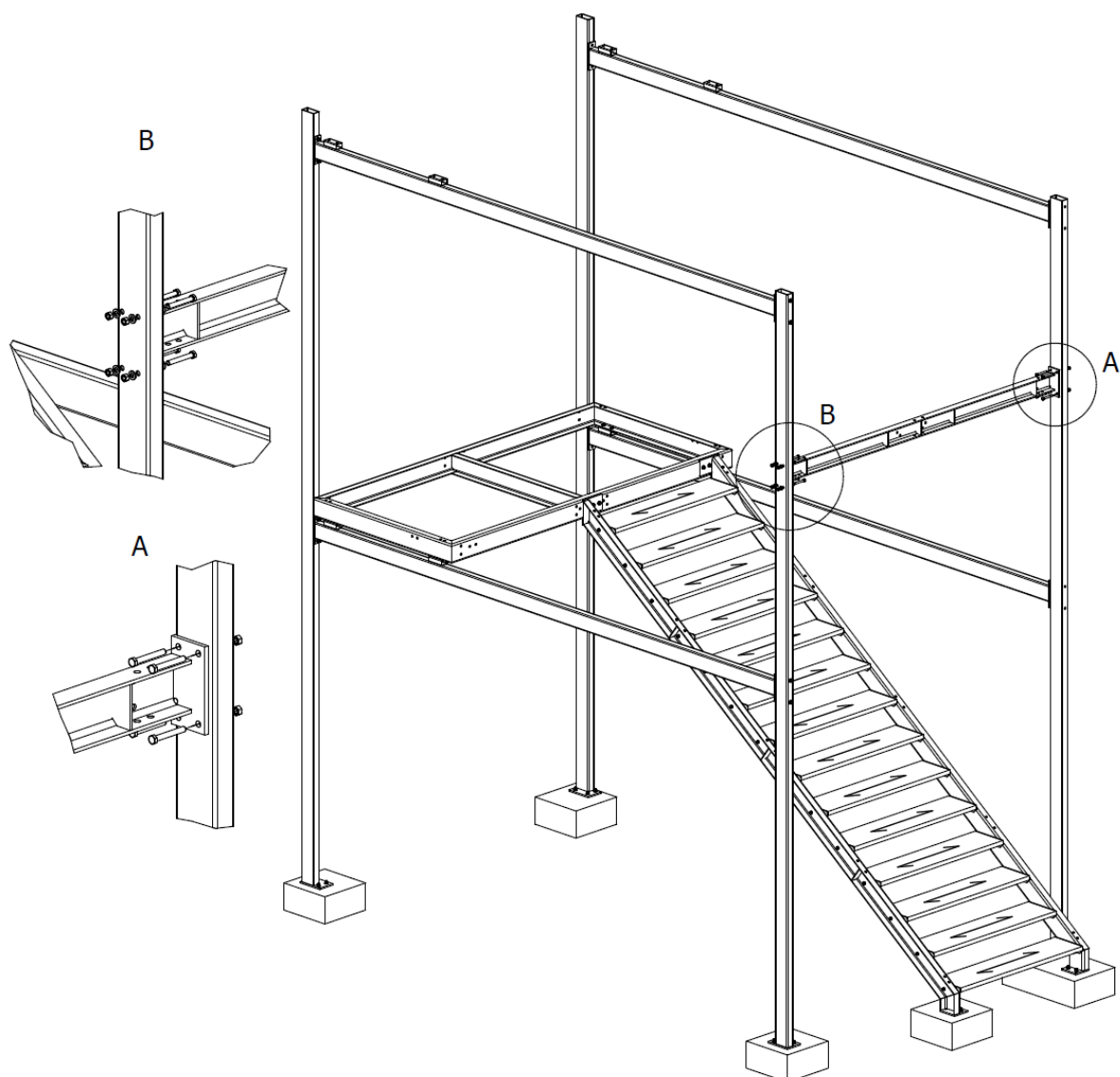
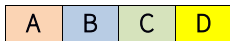

Fig. 9. Mounting the beam B-02

6.4 Mounting the flight of stairs II

It refers to the variant:



- Using a crane put the **flight of stairs II** next to the platform M-02 and the beam B-02.
- Fasten the bottom of the **flight of stairs II** to the platform M-02 using bolts M12x40, nuts M12, washers Ø12.2, while the top to the beam B-02 using bolts M12x40, nuts M12, washers Ø12.2.

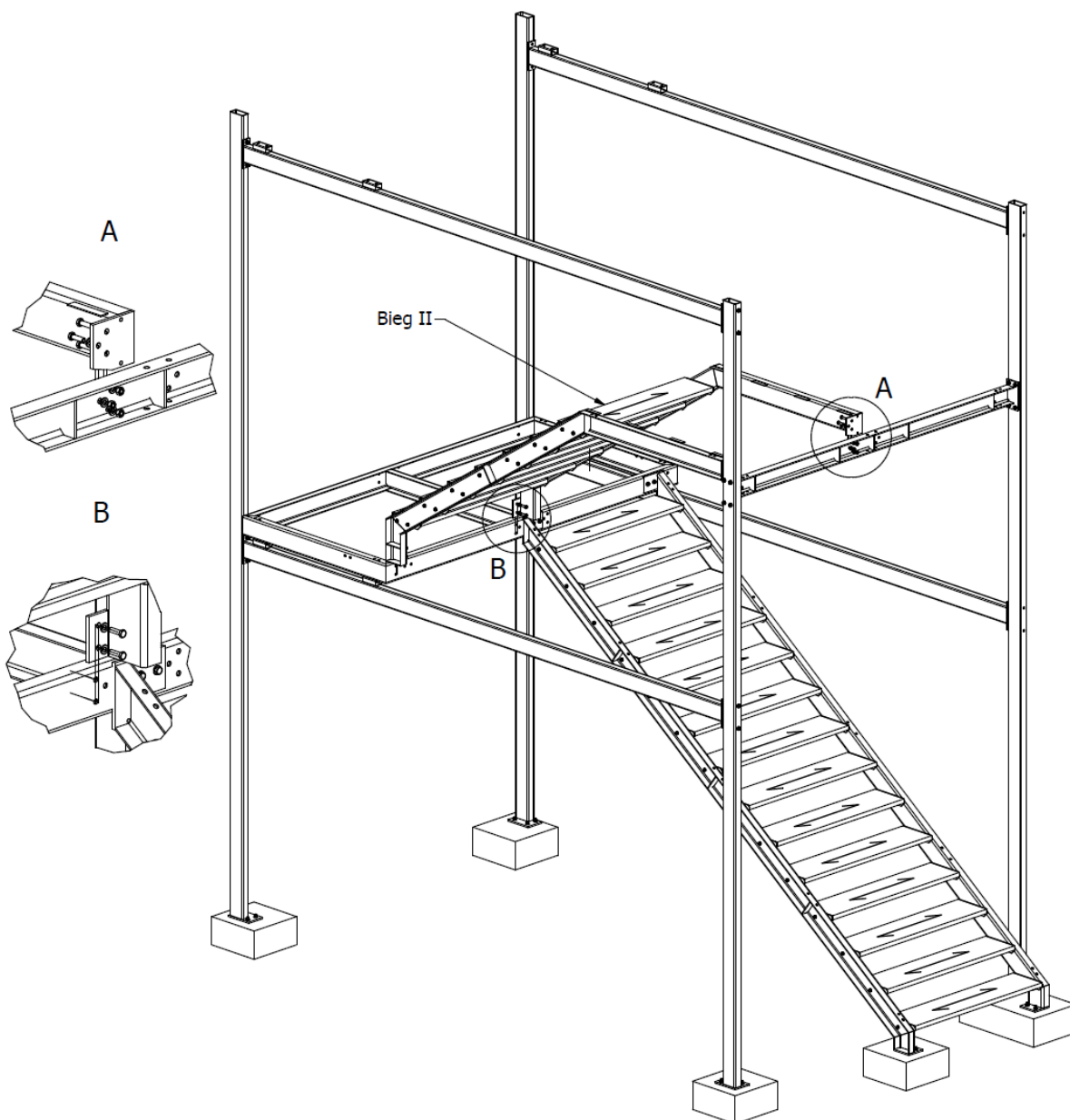
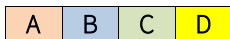

Fig. 10. Mounting the flight of stairs II

6.5 Mounting the flight of stairs III

It refers to the variant:



- Before mounting the **flight of stairs III**, mount the second **platform M-02**, as the first one. Using a crane place the second **platform M-01** on the beams B-01. Fasten it to the beams using 8 bolts M12x40, nuts M12 and washers Ø12.2.

- Using a crane place the **flight of stairs III**, mount its bottom on the **beam B-02** using bolts M12x40, nuts M12, washers Ø12.2, while its top on the second **platform M-02** and fasten using bolts M12x40, nuts M12, washers Ø12.2

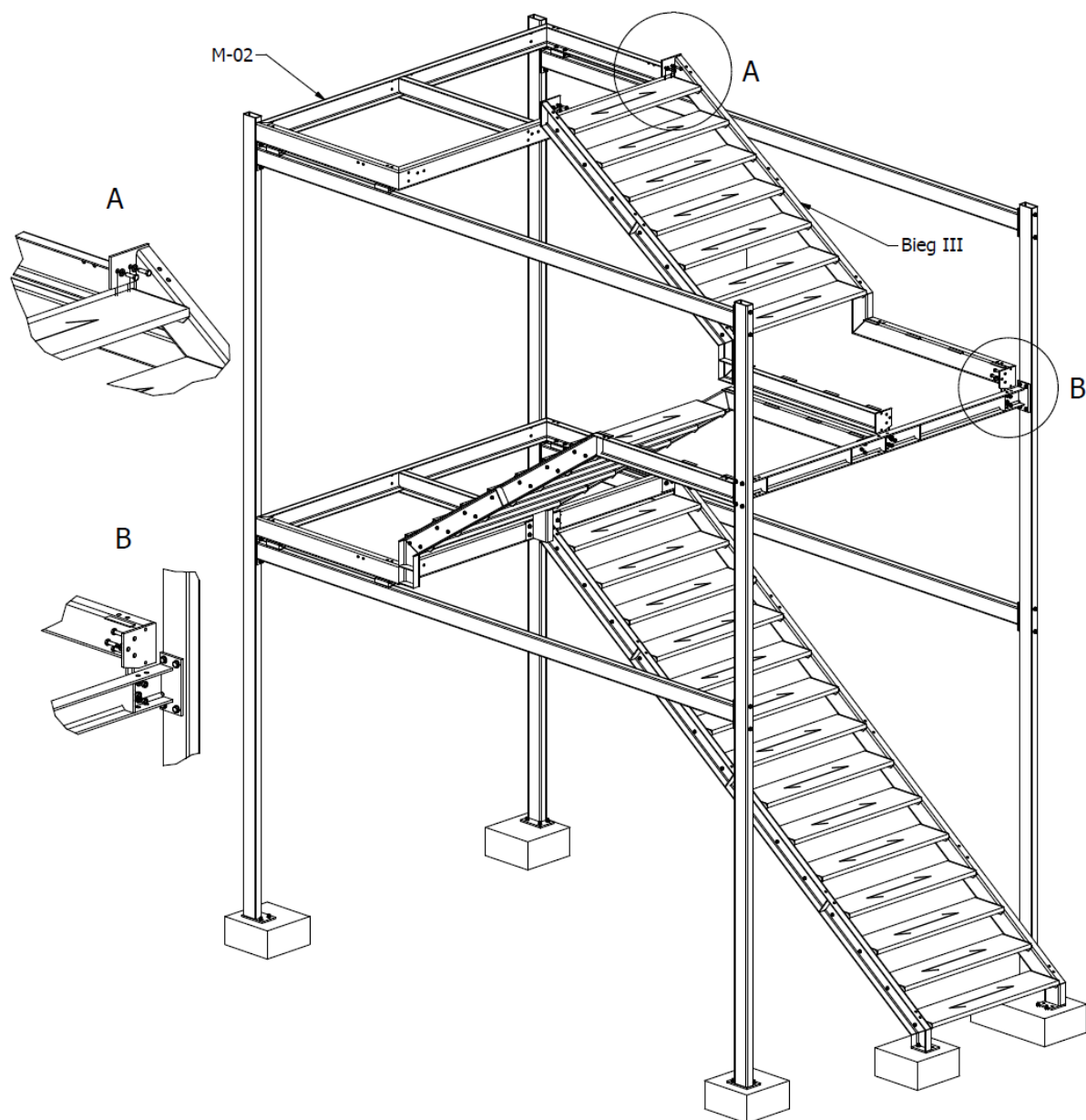
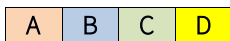

Fig. 11. Mounting the flight of stairs II

6.6 Mounting the platform grates.

It refers to the variant:



- Platform grates should be mounted in sequence starting from the bottom.

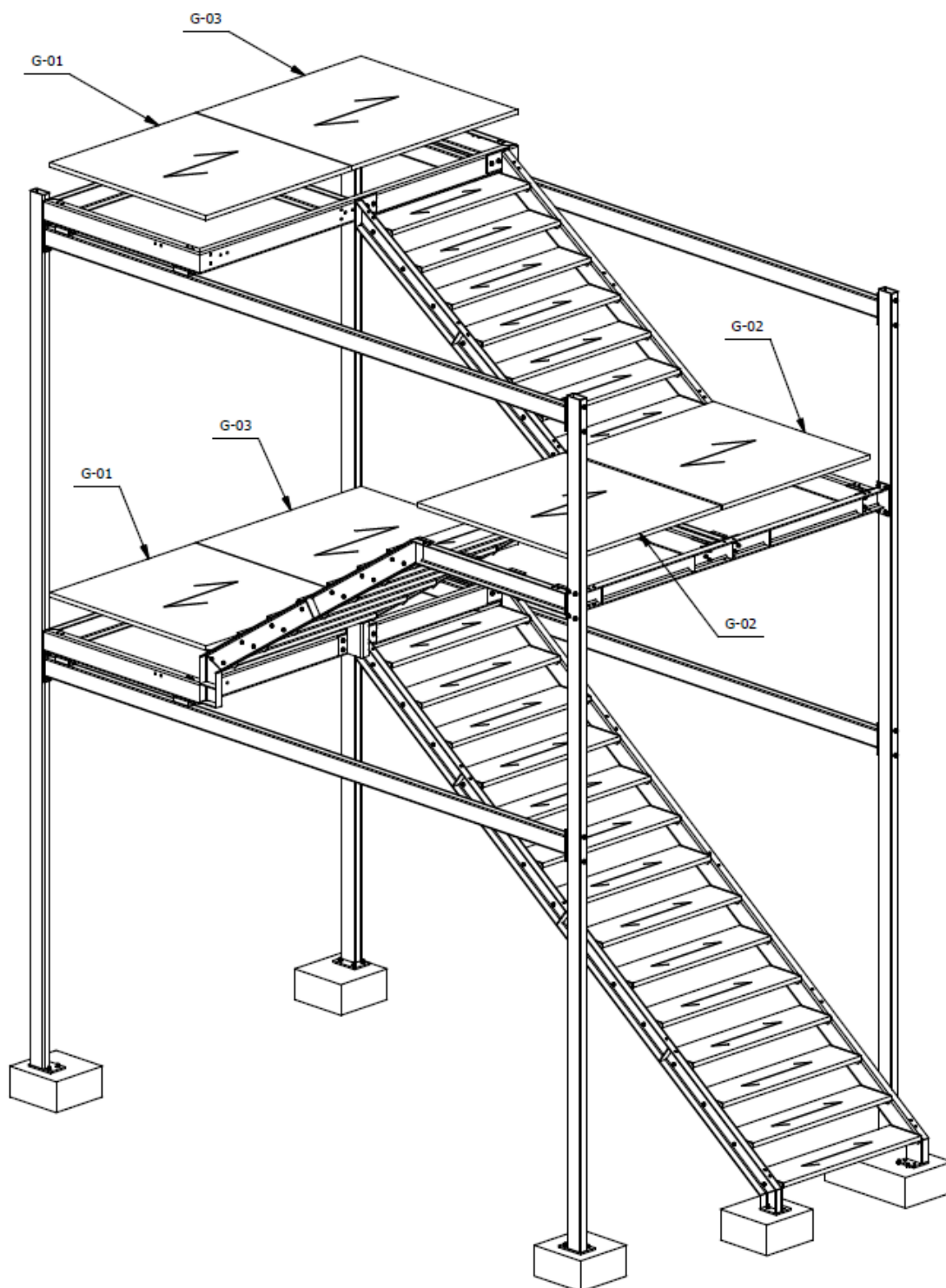

Fig. 12. Mounting the grates

- Mounting the grates using the universal brackets.

Fig. 13. Mounting the universal brackets for mounting the platforms

6.7 Mounting the railings

Mount the railings on individual flights of stairs and platforms using bolts M12x30, nuts M12 and washers Ø12.2 according to the following list:

It refers to the variant: A

- Mount the railings **R-02** on the side beams **F-05** and **F-06** of the flight of stairs I,
- Mount the railing **R-01** on the side beams **F-01** and **F-02** of the flight of stairs II
- Mount the railing **R-01** on the side beams **F-03** and **F-04** of the flight of stairs III
- Mount the railing **R-04** and **R-08** on the platforms **M-02**(lower and upper platform)
- Mount the railing **R-05** on the beam **B-02** (intermediate platform)
- Mount the railing **R-04** on the beam **B-01** (intermediate platform)

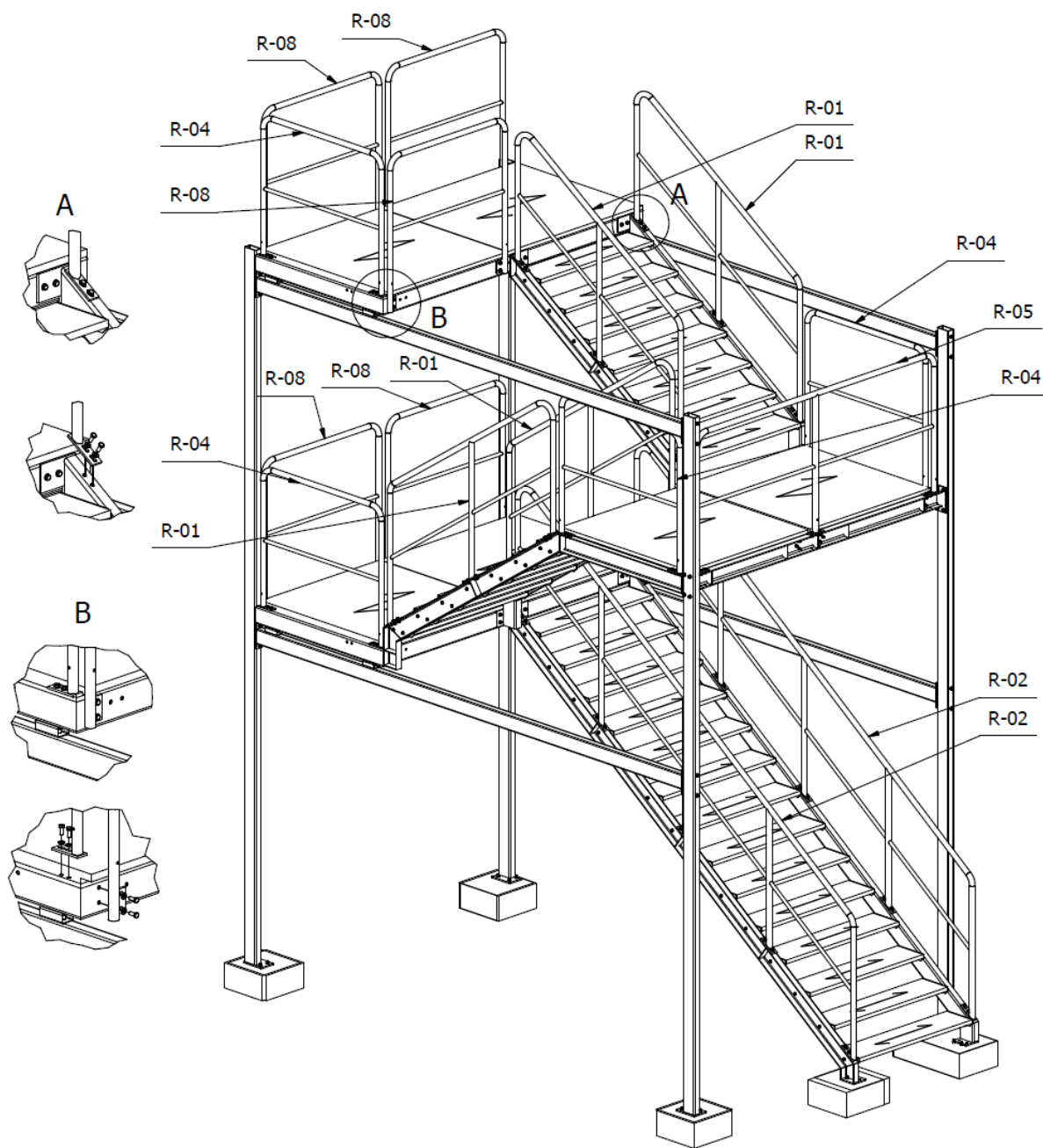

Fig. 15. Mounting the railings

- For the variant A, do not install the railings R-04.

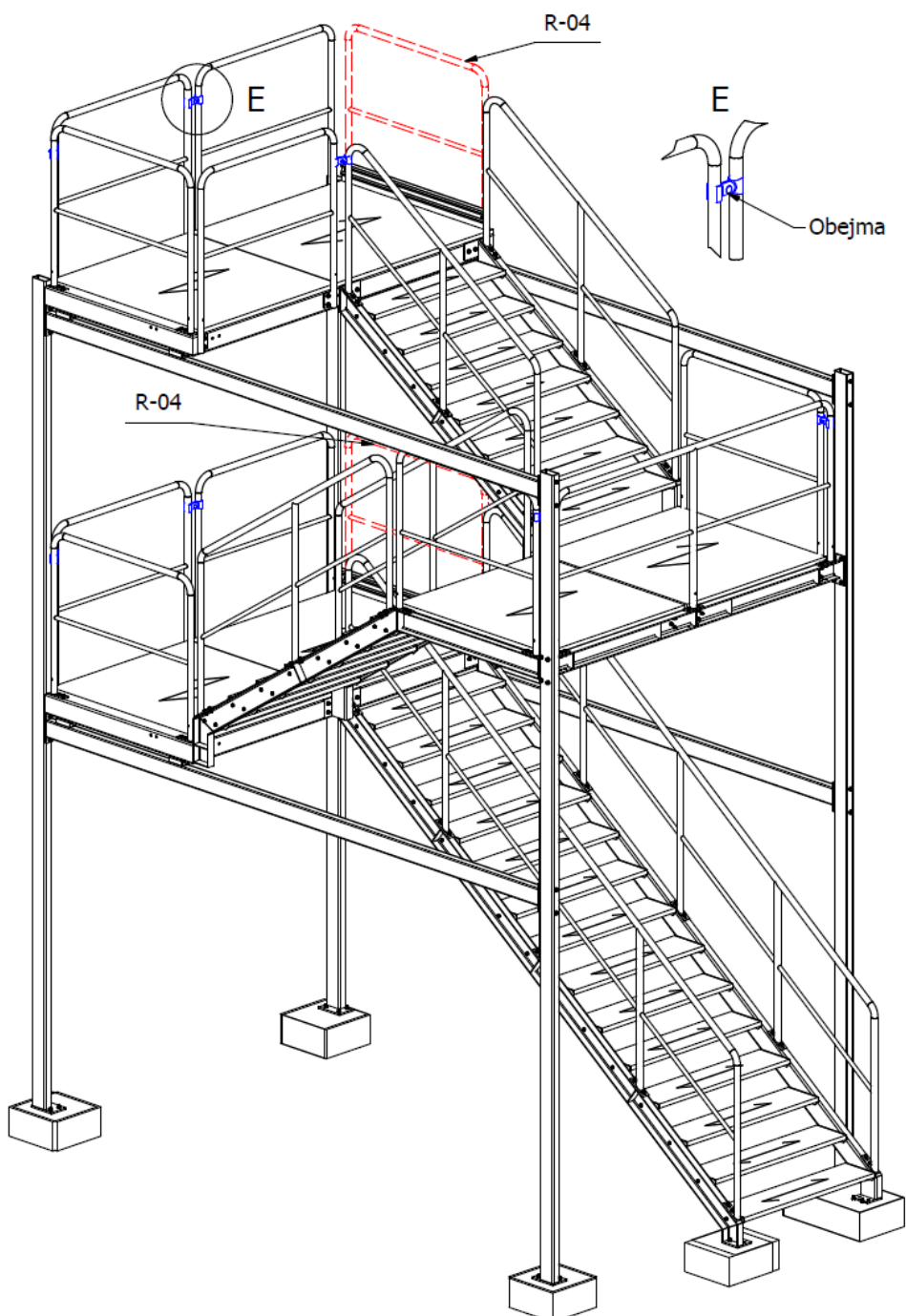

Fig. 16. Schematic arrangement of railings and brackets for the variant A

It refers to the variant: **B**

- For the variant B, do not install the railings R-04.

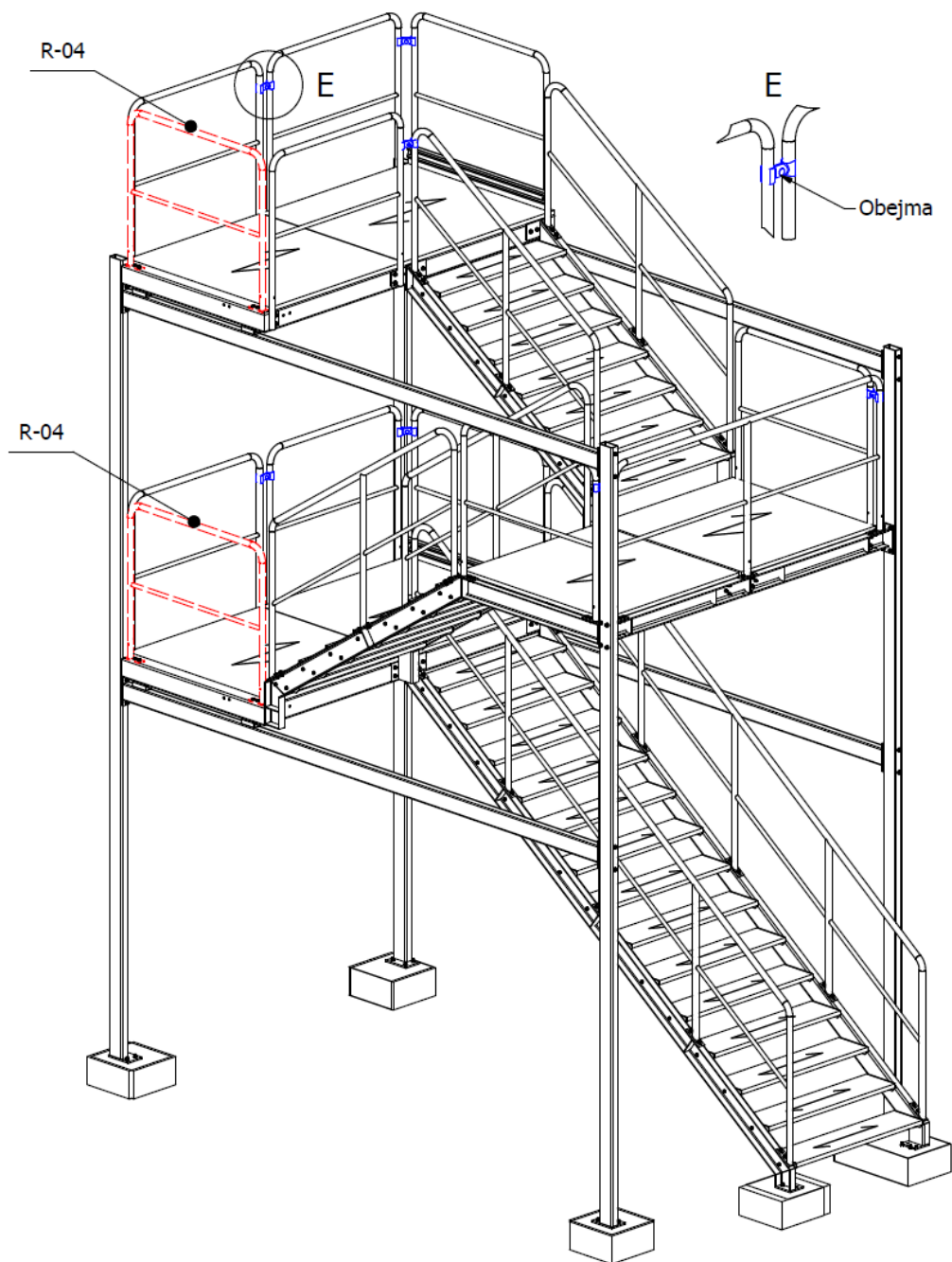

Fig. 17. Schematic arrangement of railings and brackets for the variant B

It refers to a variant: **C**

- For the variant C, do not install the railings R-04.

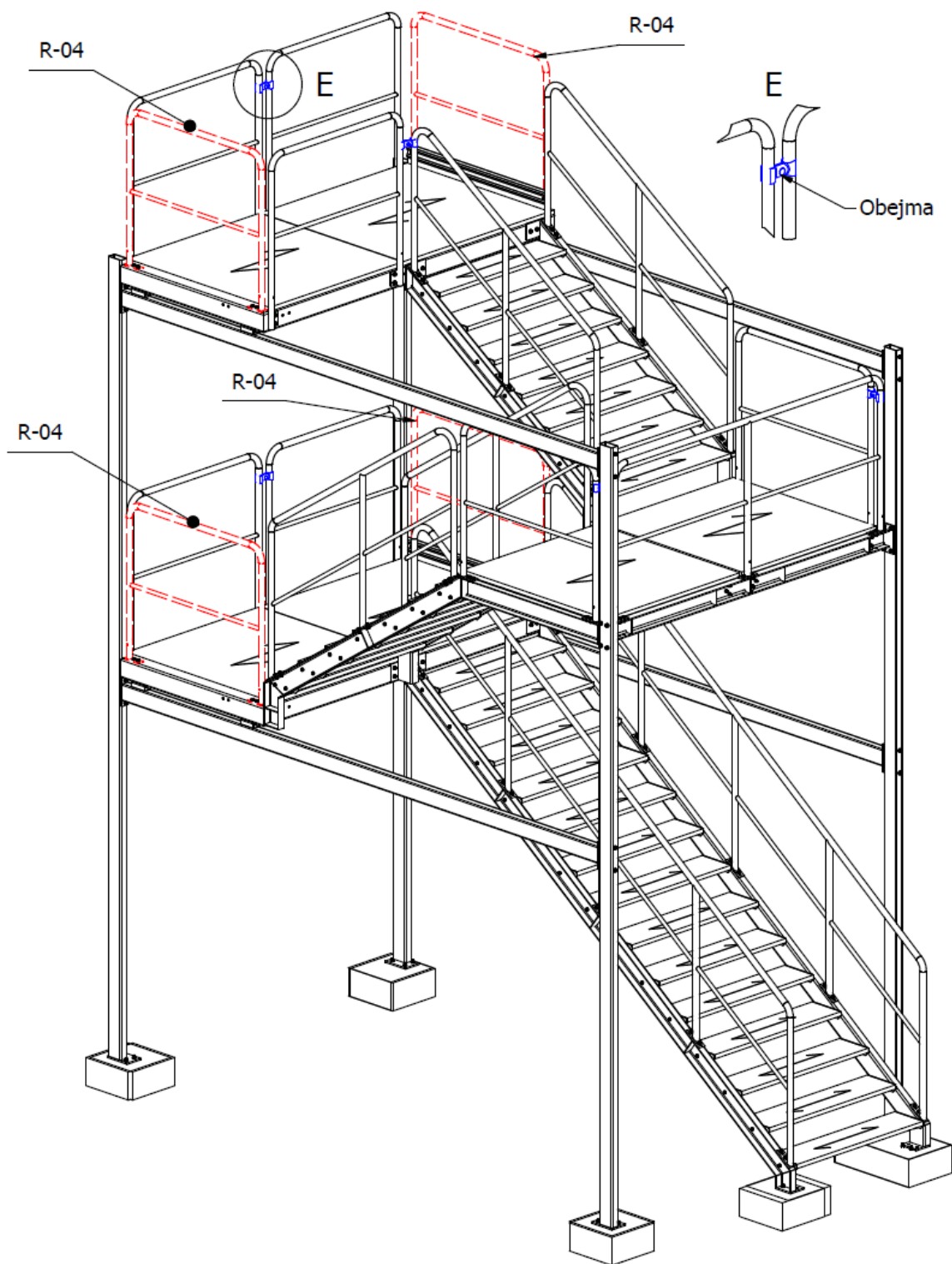

Fig. 18. Schematic arrangement of railings and brackets for the variant C

It refers to the variant: **D**

- For the variant D, do not install the railings R-04.
- Mount an additional support A-4 using bolts M12x30, nuts M12 and washers Ø12.2.

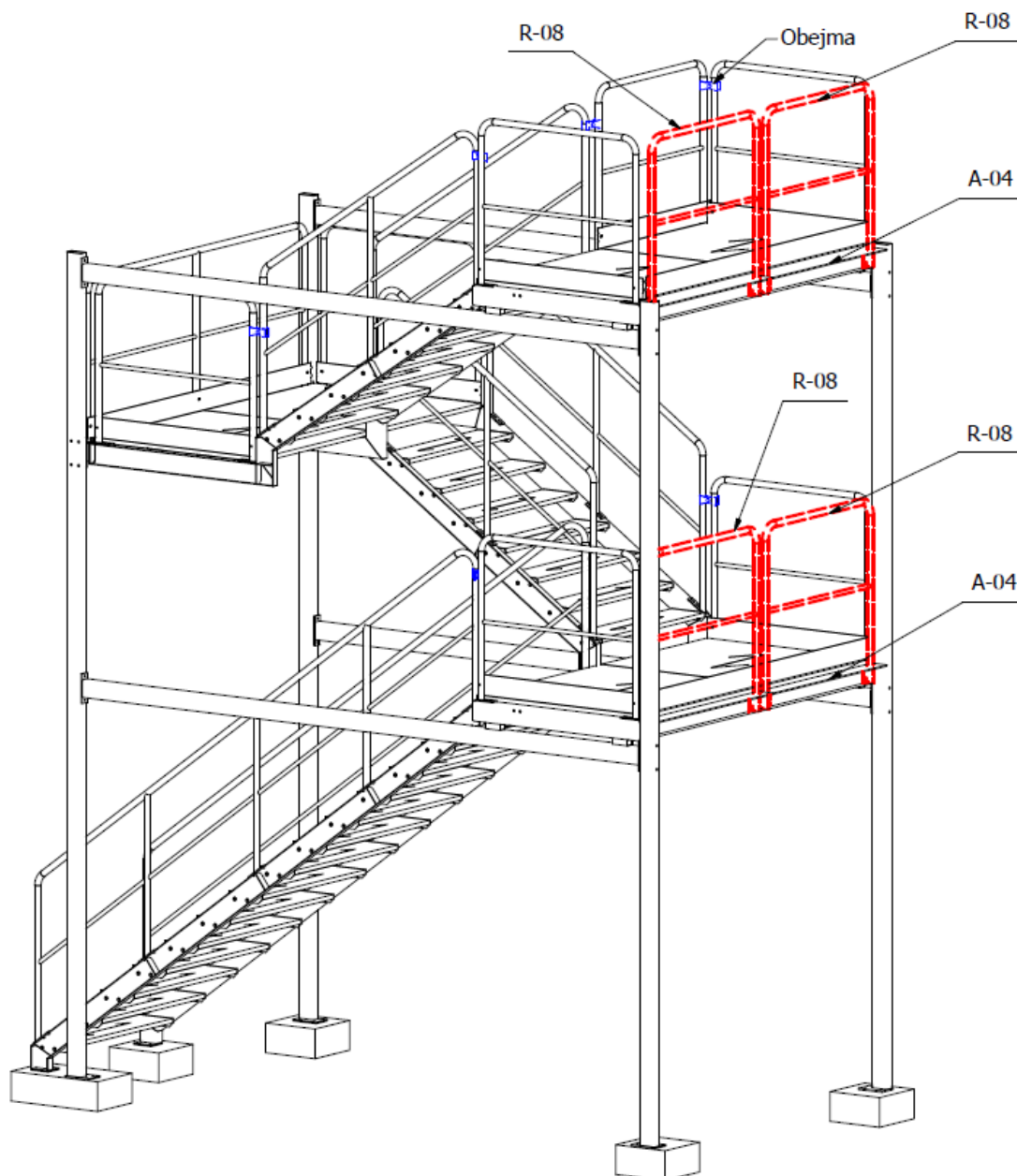

Fig. 19. Schematic arrangement of railings and brackets for the variant D

6.8 Mounting the toe-boards

- Mount the toe-boards using bolts M6x30 according to Fig. 19 using the following scheme:
 - Mount the toe-board K-03 Bt-140x1295 to the railing R-08
 - Mount the toe-board K-06 Bt-140x1330 to the railing R-04
 - Mount the toe-board K-04 Bt-140x2590 to the railing R-05

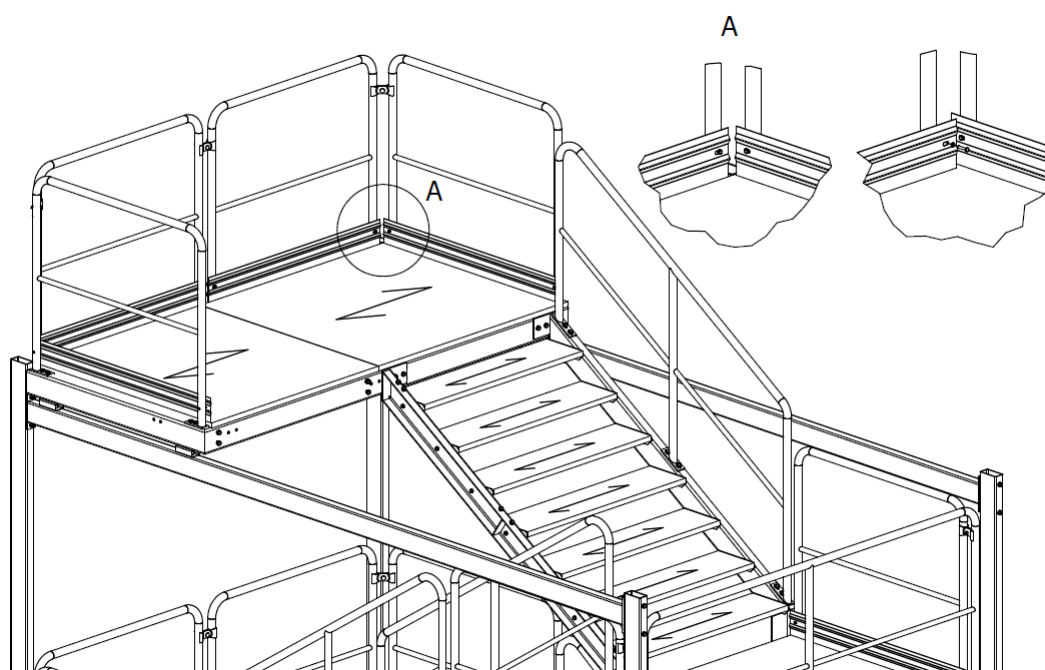

Fig. 20. Mounting the toe-boards

6.9 Mounting the railing brackets

- The railing brackets should be mounted between the tube of the railing fastened using bolts, and the tube of the railing welded permanently. The bracket should be mounted at a height of 700-800mm over the platform level using the diagrams shown in Fig. 16-18.



Fig. 21. Mounting the railing brackets

6.10 Mounting the plugs

- Mount plastic plugs 120x60 on 4 columns.

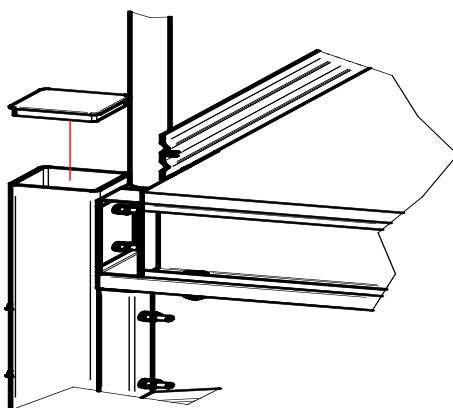

Fig. 22. Mounting the plugs

6.11 Connecting the stairs and the container set

If necessary, make a connection of the structure of stairs and the container set.

- using the connector A-02 and A-03 (Fig. 22).

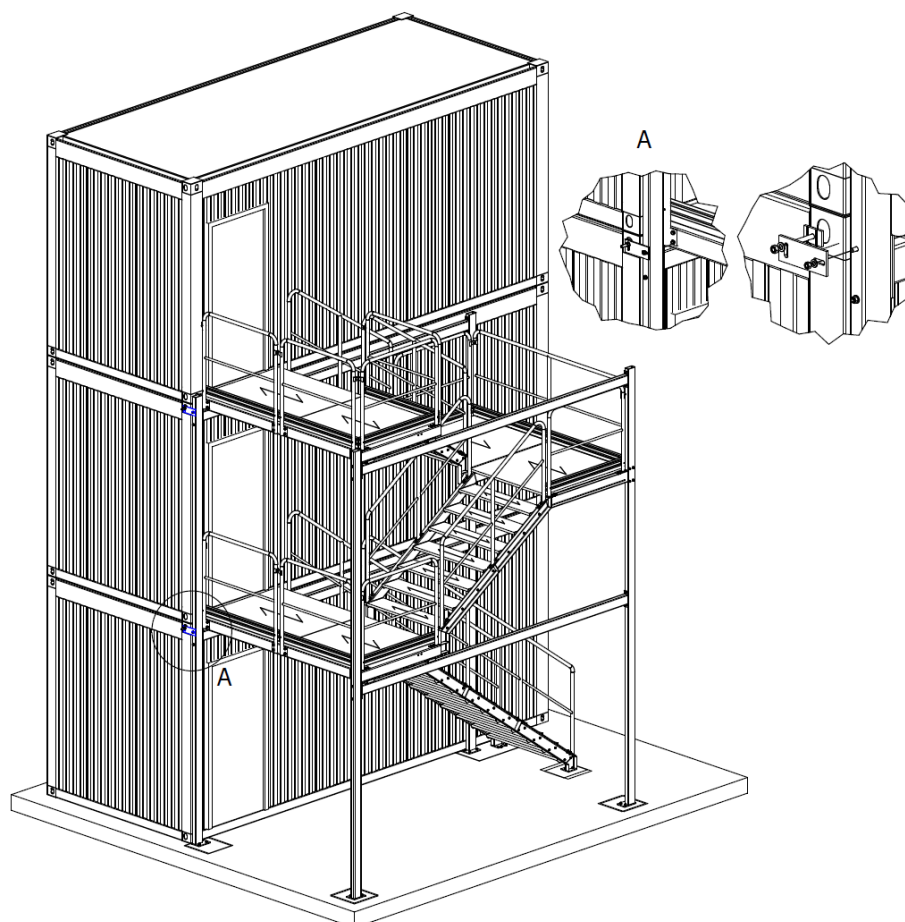

Fig. 23. Mounting the brackets

7 Adjustment and settings

To ensure proper operation during the use of the stairs, during the assembly of the individual components perform the following steps.

- During the assembly of the columns, check vertical position, as well as the correct position of the column in relation to the container. If necessary, adjust the position by placing spacers under the pedestal of the column.
- During the assembly of the railings, set the appropriate spacing between vertical tubes. To do this, use the oval holes in the railing brackets.
- In the event of loosening and collapsing of the railing bracket, set it at the correct height and tighten the bolt.



The range of activities related to the adjustment and settings also includes inspections and possible tightening of screw connections.

8 Labelling

After completing the assembly of the stairs, before commissioning them, mount (if it has not been already done as a part of the delivery) – the nameplate. The nameplate should be placed in a visible place.

9 Operation



Use the staircase in accordance with its intended purpose, preventing the emergence of situations such as:

- Excessive load of the steps and grates by stopping and staying of a greater number of people for a longer time, leaving heavy objects, hanging weights, etc.



Stairs are the construction intended for the loading density of the steps and platform not exceeding 1.0kN/m^2

- Loading the construction of the stairs with a force acting at an angle to the axis of the columns.
- Loosening the screw connections.
- No individual components.

9.1 Safety rules



General safety rules regarding operation of stairs are defined on page 3. In addition to the above, the following are required from the User:

- Stairs are operated according to the general health and safety provisions.
- Container stairs can be assembled only by persons who are familiar with this manual.
- Before using the container stairs, all components must be inspected for their proper assembly.
- Do not hang on components nor place on platforms any electrical wires that are energized. Such wires can be hazardous because of the risk of damage to the insulation.
- Do not lean on the railings with all of your weight.
- Do not lean out by moving your centre of gravity outside the railing.
- Do not slide on the railings.
- Replace damaged components with new ones, that are consistent with the list of parts.
- During repairs be careful warning others about works conducted and inform everybody about the stairs off from use.
- Do not put your hands or other body parts between structural elements (danger of crushing).

- On the surface of platforms and steps do not leave any objects that may cause users to slip or that are likely to fall from a height penetrating through the grates.

9.2 Manufacturer's recommendations



To ensure the longest life and reliability of stairs, the following are recommended:

- Storage and transport of components on wooden or rubber spacers eliminate scratching of the protective surface.
- When lifting with a crane or forklift, use wooden transport belts and spacers instead of metal hooks or chains.
- Keep the stairs in proper cleanliness. Do not use greasy petroleum-derived agent for cleaning or maintenance.

10 Protection



The role of protection against falls from height meet barriers that make up the string from the ground on which they are sited stairs up to the entrance to the container on the highest level. Their fitting must be through the life-to-date checked and adjusted.

11 Inspection and Maintenance

Provided stairs are the structure that does not require maintenance by qualified personnel. Nevertheless, in order to ensure the longest operation, at least once a year you should carry out a periodic inspection and maintenance work, concerning:

- Inspection of the technical condition of individual components.
- Verification of the correctness of tightening screw connections.
- In the case of the protective surface scratched, making all the necessary painting to prevent the development of the corrosion process.

Tab.3. The maximum tightening torques of threaded connections

Thread dimensions [mm]		Tightening torque [Nm]		
Nominal diameter	Scale P	Mechanical property class		
		8.8	10.9	12.9
10	1.5	43	63	74
12	1.75	73	107	125
16	2	156	228	267

12 Disassembly

In the event of necessity to disassemble the stairs:

- Dismount the toe-boards.

- Dismount the railing brackets.
- Dismount the railings.
- Dismount the platforms starting with the highest ones.
- Dismount the flights of stairs using a crane. Secure columns from falling. Loosen the bolts securing the steps.
- Dismount the columns with the side beams.

13 Replacing damaged components

During repairs be careful warning others about works conducted and inform everybody about the stairs off from use.

13.1 Replacing the step

In the case of damage of a step in any of the flights of stairs, you should:

- Loosen the bolts securing the adjacent steps.
- Dismount the bolts securing the damaged step.
- Remove the damaged step and mount a new one.
- Mount the mounting bolts with nuts and washers.
- Tighten the screw connections securing the adjacent steps.

13.2 Replacing the platform

In the case of damage of platform grate, you should:

- Dismount the universal brackets.
- Replace the platform grate.
- Mount the universal brackets.

In order to facilitate the disassembly of the platform you can, with a special precaution, remove the selected railings.

13.3 Replacing the railings

In the case of damage of a railing at any level or flight of stairs, you should:

- Dismount the railing brackets.
- Dismount the mounting bolts.
- Replace the railing.
- Tighten bolts and nuts.

14 Troubleshooting

In the event of a fault, you can identify its cause and remove it using the information given in the table below.

Tab. 4. The most common faults

Fault	Cause	Repair
Moving railings, steps, platforms	Loose bolts or lack thereof Loose railing brackets or lack thereof	Tighten/complement the mounting bolts or the railing brackets
Moving the entire structure of the stairs	Lowering of one of the foundation pedestals and loosening of the nuts	Align the foundation pedestal to the level of the other pedestals, and tighten the nuts

15 Disposal

Packaging and discarded equipment must be stored, managed or disposed in accordance with applicable recommendations and requirements specified in the Law of 27.04.2001 on waste (Journal of Laws of 2001, No. 62, item 628), as amended.

Place

Date

CERTIFICATE

Employees of the company were trained in the assembly and disassembly of the “Container steps” according to the Operation and Maintenance Manual.

List of employees trained:

1.

2.

3.

4.

5.

(employee)

(signature)

Signature conducting training

.....