

Operation-maintenance documentation

TUP Unloading Platform System

TUP-1.25, TUP-1.5, TUP-2.2

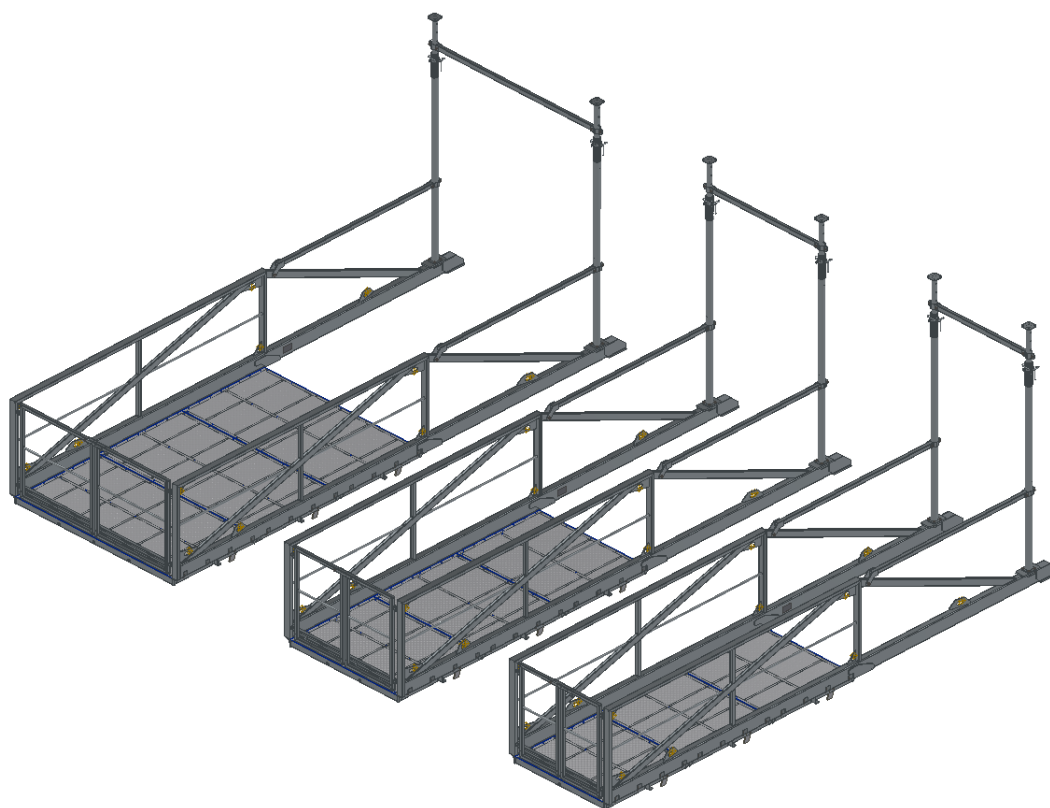

Piotr Abram
(Prepared by)

(Signature)

Robert Cieśla
(Checked by)

(Signature)

Miłosz Muzyka
(Approved by)

(Signature)

Edition 1.5, March 2023r.

Table of changes

No.	FULL NAME	DEPARTMENT	CHANGE DATE	SCOPE OF CHANGES	COMMENT
1	Piotr Abram	R&D	24.03.2022	Point 2.2	
2	Piotr Abram	R&D	09.06.2022	Point 2.3	
3	Piotr Abram	R&D	07.03.2023	Point 2.2 information about individual safety equipment	
4					
5					
6					
7					
8					
9					
10					
11					
12					
13					
14					
15					

Table of contents

1. Introduction.....	4
2. System usage.....	4
2.1 Assembly.....	5
2.2 Technical information and use.....	5
2.3 Storage and transport	7
2.4 Damaged elements of unloading platform	12
3. Risk and danger analysis.....	13
4. Additional information.....	13
5. Attachments.....	13

1. Introduction

The following operation-maintenance documentation describes the unloading platform (construction outrigger platforms) manufactured by TLC Sp. z o.o. The main aim why the product was developed and implemented, was to facilitate transport of materials between the tiers of a building. It follows the requirements of the Polish Ministry of Infrastructure from February 6th 2003 in terms of OHS at the construction site (Dz.U.nr 47, poz.401). The unloading platform has been developed according to Polish and European standard PN-EN 12811-1 "Temporary works equipment – Part 1: Scaffolds – Performance requirements and general design."

The platform is a complete solution providing proper unloading area for materials transported with construction cranes and other lifting equipment.

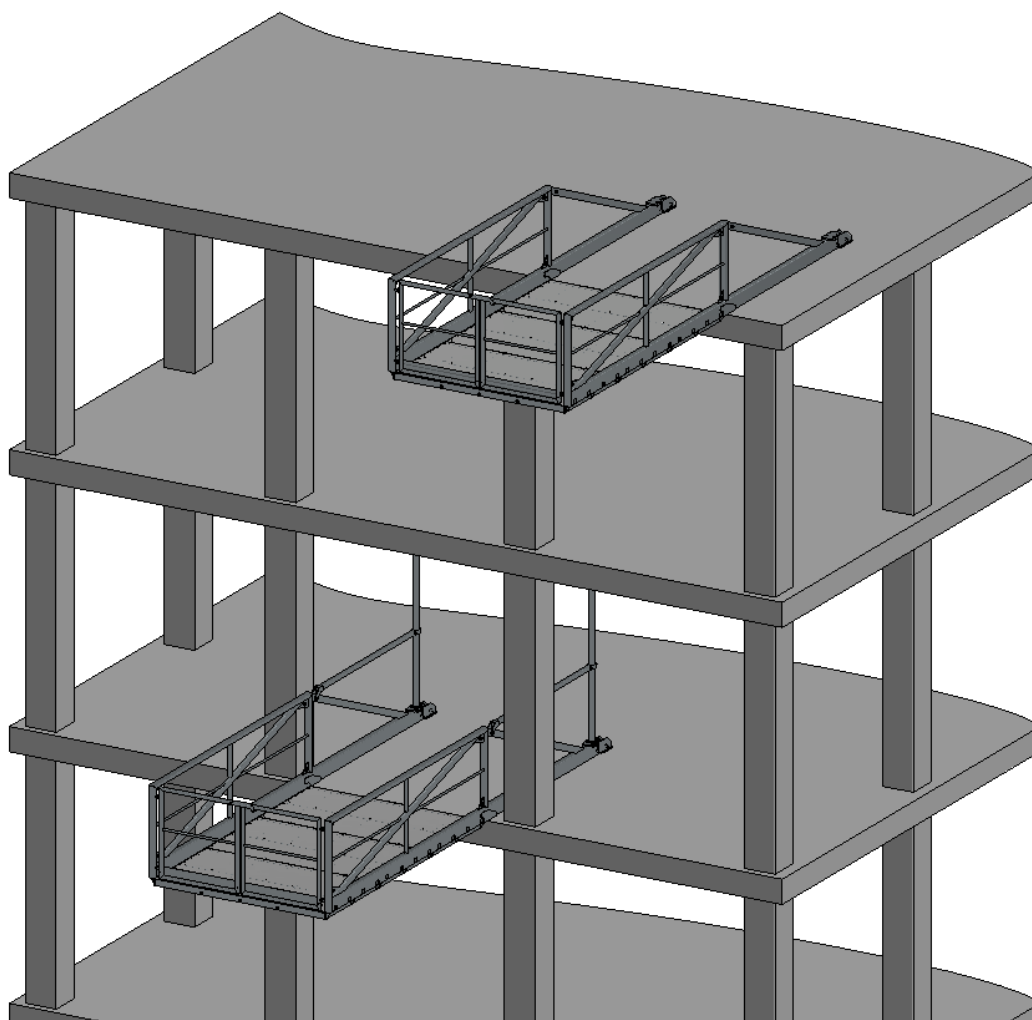

Drawing 1. Unloading platforms

2. System usage

2.1 Assembly

The assembly should be conducted according to the assembly manual and current OHS regulations.

The structure of the unloading platform allows for two assembly variants – through strutting between ceilings or by anchoring to the roof.

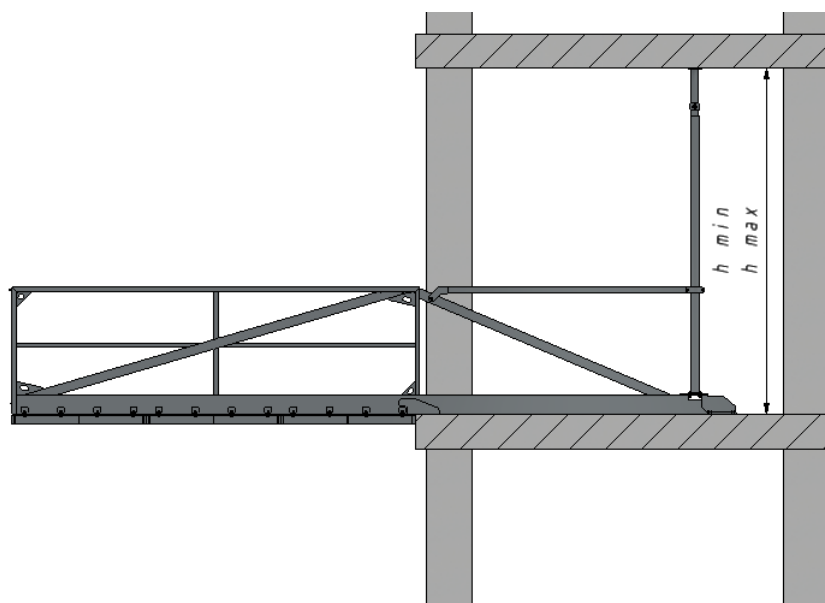

Drawing 2. Assembly between ceilings.

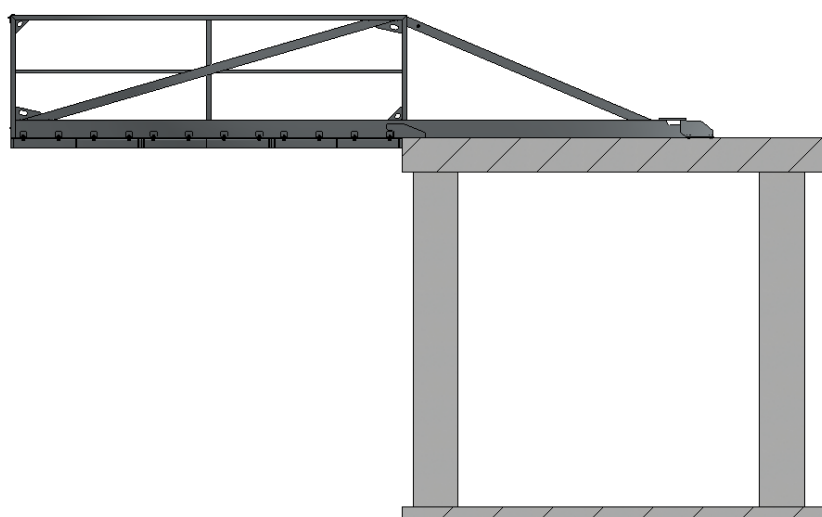

Drawing 3. Assembly by anchoring to the roof.

2.2 Technical information and use

The unloading platform is made of beams (grid). The floor is made of three landings made of steel frame and aluminium lining. Platform edge is secured with a gate locked with a bolt. All steel elements are covered with anti-corrosive layer.

Unloading platform technical data:

- Maximum workload: 4000 kg (on 1 m² area)
- Dimensions:
 - TUP-1.25 – 6300 x 1410mm
 - TUP-1.5 – 6300 x 1660mm
 - TUP-2.2 – 6300 x 2360mm
- Unloading Surface dimensions:
 - TUP-1.25 – 3500 x 1250mm
 - TUP-1.5 – 3500 x 1500mm
 - TUP-2.2 – 3500 x 2200mm
- Weight:
 - TUP-1.25 – 650 kg without slab props / 703 kg with supports
 - TUP-1.5 – 681 kg without slab props / 734 kg with supports
 - TUP-2.2 – 759 kg without slab props / 812 kg with supports
- Material: steel S355, aluminium 5754 H22
- Anti-corrosive layer: hot-dip galvanisation, powder painting

The use of unloading platform must be conducted according to the OHS regulations, field instruction of the construction site and the following manufacturer recommendations:

- this operation-maintenance documentation should be read and understood prior to assembly, disassembly or transport of the unloading platform,
- works related to assembly or use of the unloading platform should be conducted by a trained personnel,
- the personnel working at height, including assembly, disassembly and transport of the platform must be protected from falling from height,
- after assembling the unloading platform, the structure should be checked if assembled properly,
- only original components and spare parts can be used,
- all platform elements should be checked for damages,
- the structure must be earthed (PN-78/M-47900/01),
- it is forbidden to exceed the maximum allowed workload of the platform,
- it is forbidden to use platform components that are damaged,
- it is forbidden to leave or store load on the platform,
- load should not be dropped on the platform,
- it is recommended to evenly distribute the weight on the platform,
- there should be no more than 2 people on the platform simultaneously.

During assembly and use of the platform, when it is necessary to open the gate, fall protection in the form of safety harnesses must be used. The unloading platform is equipped with mounting points

to which the harness hook should be attached. It is allowed to save personal protective equipment also to points intended for attaching crane slings.

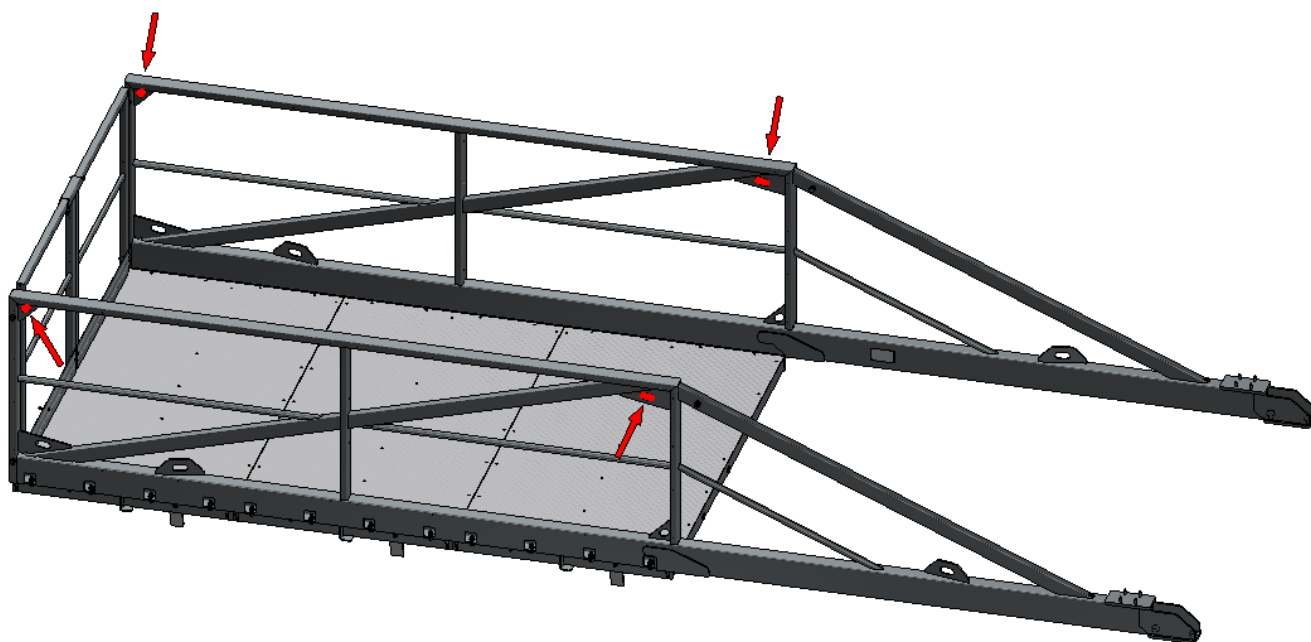

Drawing 4. Safety harnesses attaching points

It is allowed to install advertising canvas covers in the form of prints on materials such as tarpaulins or mesh. Installation of such covers should be done with the use of bands or using pre-drilled holes prepared by the manufacturer for the installation of panels. It is not allowed to make new openings in the structure. The weight of the coatings should not exceed 50 kg.

2.3 Storage and transport

Steel parts of the unloading platform are protected with hot-dip galvanisation according to PN-EN ISO 2081 or PN-EN ISO 1461 and powder painted. It guarantees a long term use of the components in different environmental conditions. Following recommendations below will allow for longer use of the platform in different environmental conditions. Additional guidelines are as follows:

- avoiding the content of platform elements with substances that cause damage or steel corrosion and damage the anti-corrosive layer,
- use of the platform according to its destination,
- protecting platform elements from mechanical damages that can cause anti-corrosive layer damages,
- in case of a need to hit platform elements through materials absorbing the surge: elastomers (rubber), wood, etc.,
- cleaning platform elements with substances that do not damage the anti-corrosive layer,
- avoiding weather factors such as rain or snow during storage,
- proper storage.

Because of a modular structure of the unloading platforms, their transport can be done while disassembled. There is a possibility to transport the platforms while assembled (with or without props). To transport the platforms with a lifting equipment use 4 slings, location shown on drawing.5. The angle α depends on the height of the storey – this dependence is presented in Table 1, in which the approximate length of the slings is given. Appropriate selection of slings prevents their collision with the ceiling (Drawing 6).

α [°]	H [mm]	L [mm]
77	2600	4300
73	2700	4500
69	2800	4700
67	2900	4800
66	3000	4900
64	3100	5000
63	3200	5100
61	3300	5200
60	3400	5300
59	3500	5400
58	3600	5500

Table 1. Sling angle

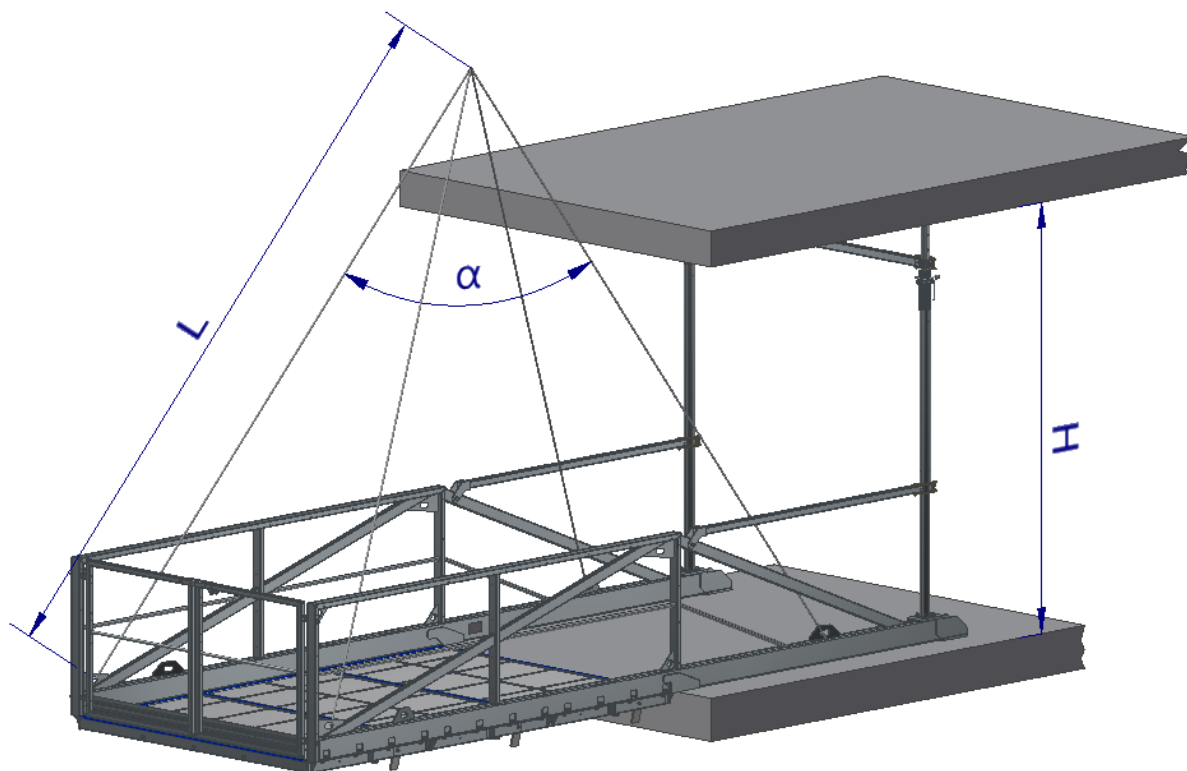

Drawing 5. Sling assembly for transport.

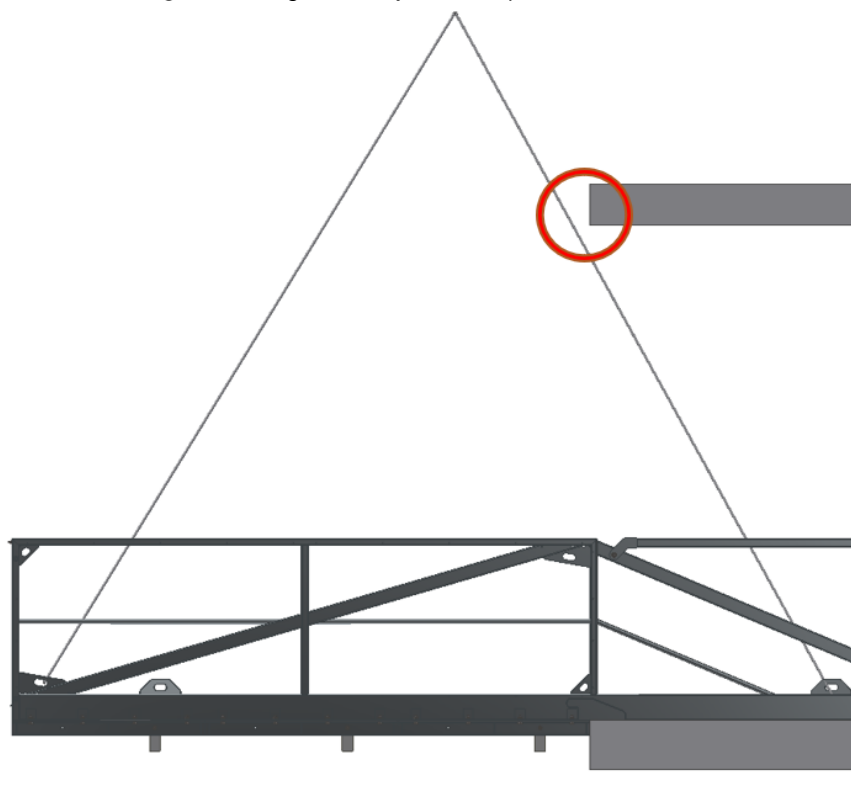

Drawing 6. Sling collision point with slab.

It is allowed to assemble the platform with the slab props installed, if the slings are fixed to anchoring points in the working area of the platform. In this case, the platform is transported tilted to the horizontal by a maximum of 10°. The sling angle α should be 45°.

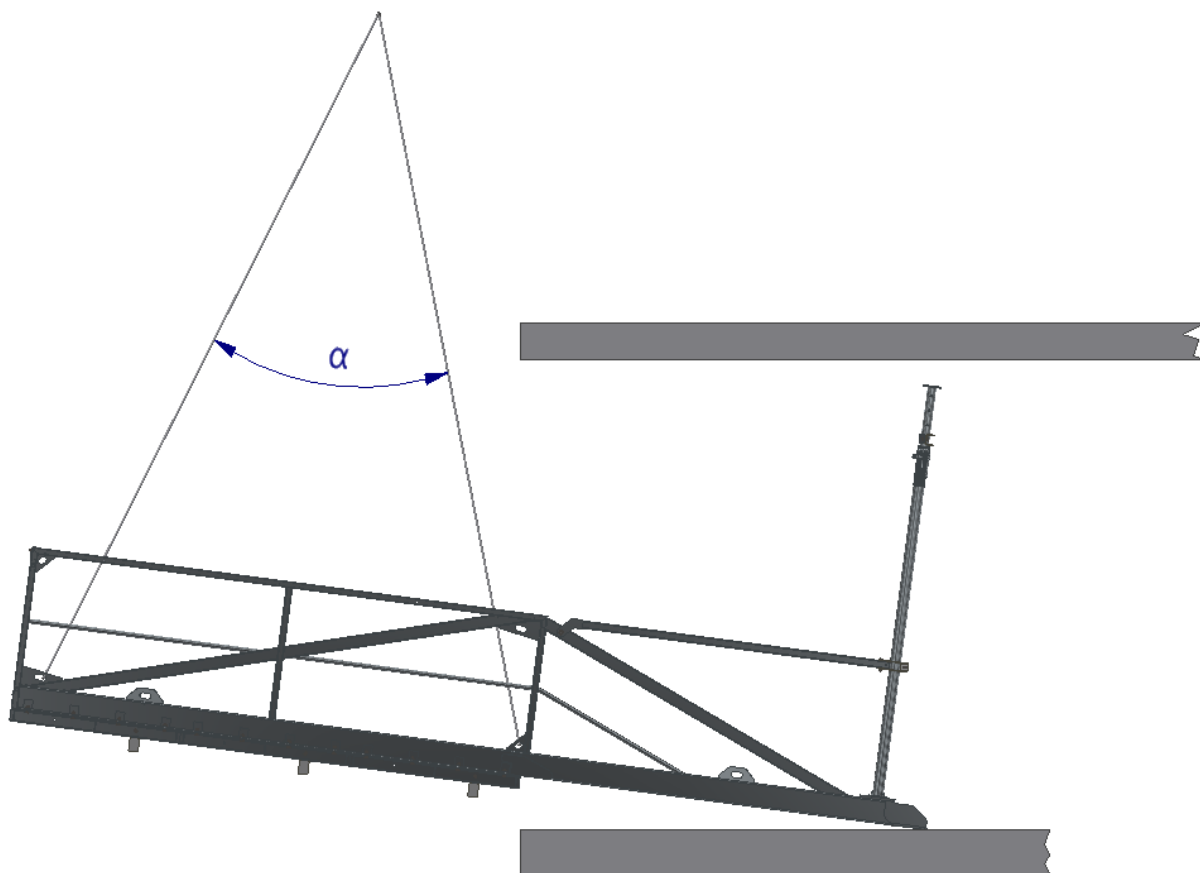

Drawing 7. Transport of tilted platform to installation place.

Transport and storage of unloading platforms are possible in both assembled and disassembled structure.

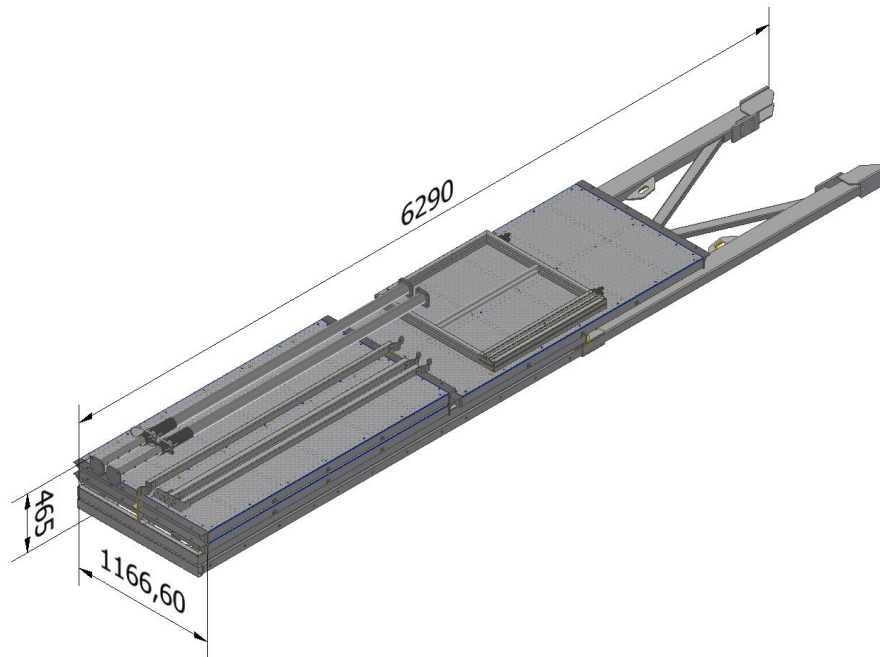

Drawing 8. Transport and storage of unloading platform

Before storing assembled platform, unfold the feet located at the bottom of the platform. The feet ensure stability while stacking.

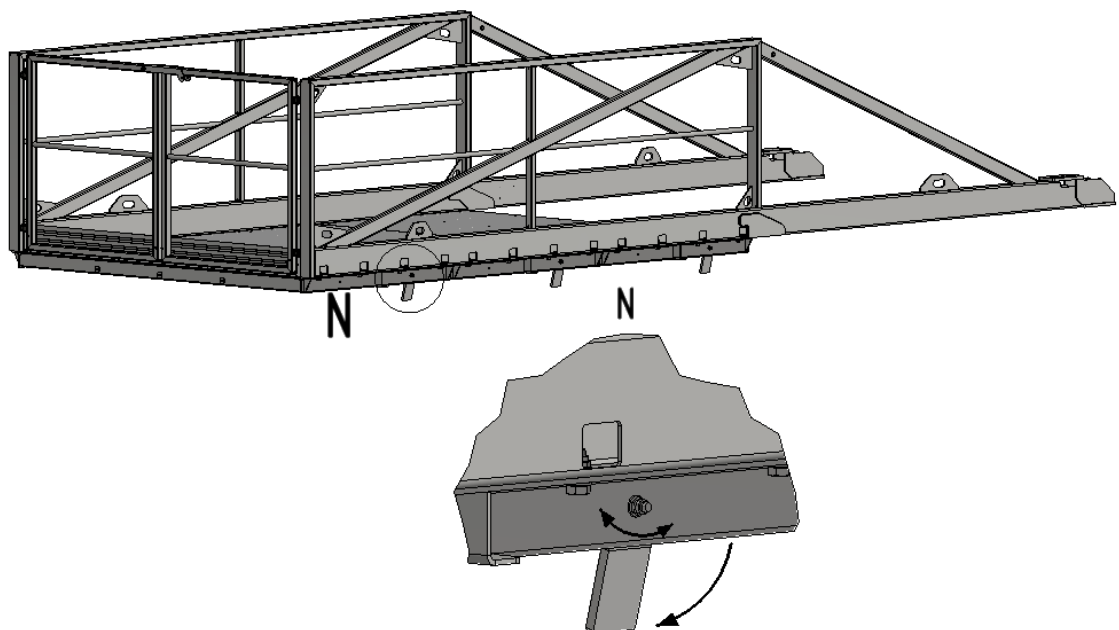

Drawing 9. Unfolding platform feet.

It is allowed to stack maximum 3 platforms while storing, or 2 while transporting. During storage and transport, the first platform should be put on at least 100mm high wooden underlays.

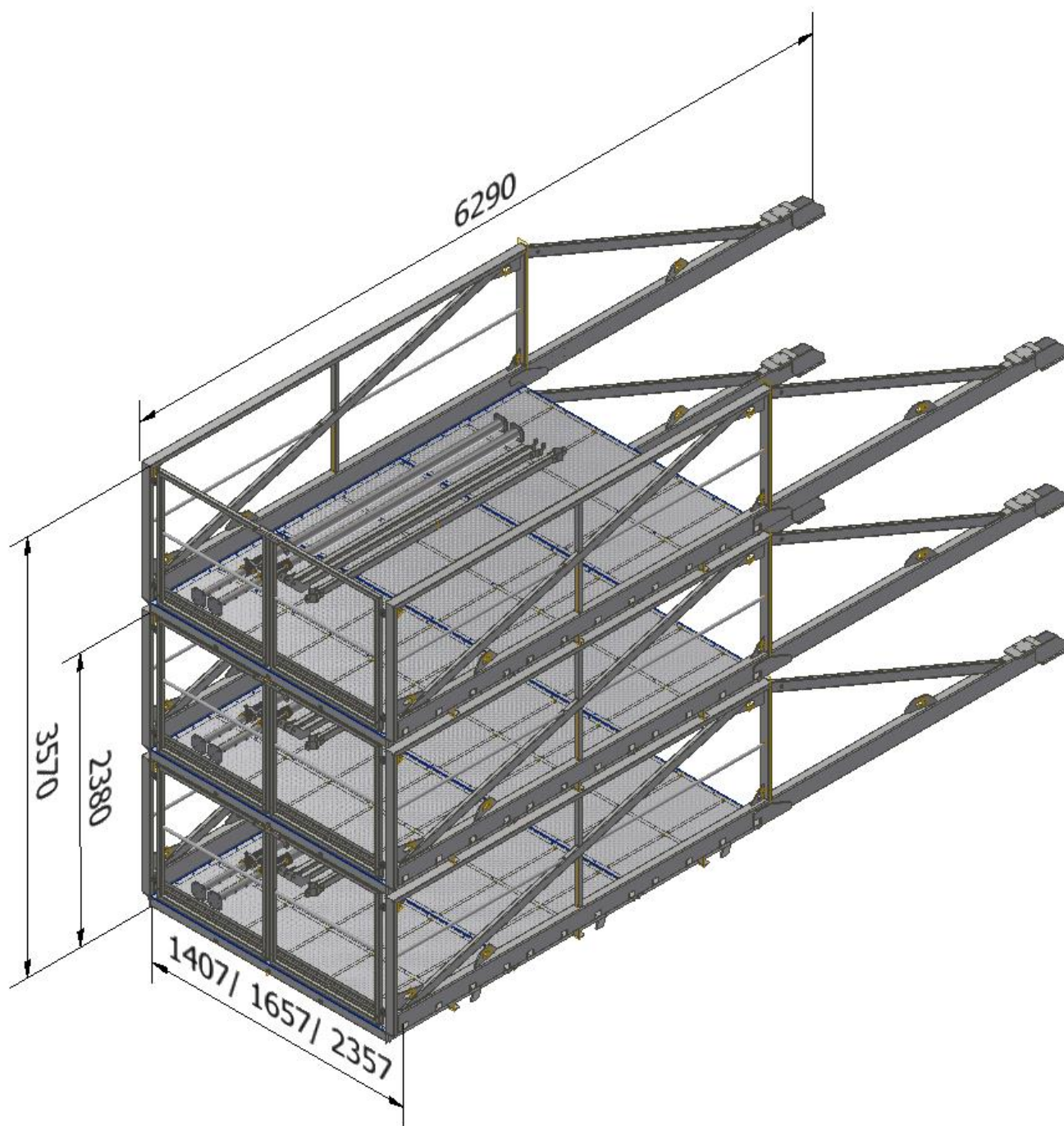

Drawing 10. Transport and storage of assembled platform

2.4 Damaged elements of unloading platform

In case of damaging platform elements, they should be stored in the intermediate storage area and marked as “damaged” or “battered”.

Damaged elements can be repaired by a manufacturer after arranging the conditions.

3. Risk and danger analysis

Risk analysis is performed to prevent dangers and limit occupational risk associated with assembly, use, disassembly, storage and transport of unloading platforms. According to the regulations, such analysis should be designed in the form of a workplace instruction. Manufacturer (TLC Sp. z o.o.) can prepare such instructions on demand.

4. Additional information

TLC Sp. z o.o. reserves the right to make corrections and improve the product as needed. This document describes the state of the product at the time of its release and may differ from later versions of the product.

TLC Sp. z o.o. does not provide any guarantees or warranties, including contractual and any resulting from applicable law, for the use of unloading platforms specified in this publication contrary to its intended purpose.

TLC Sp. z o.o. is not responsible for random accidents during the assembly resulting from failure to comply with OHS regulations and failure to take into account the conditions of special development and media layout in the vicinity of the installation site of unloading platforms.

TLC Sp. z o.o. is not responsible for any damages caused to the user and third parties resulting from the use of the platform contrary to information from this publication.

5. Attachments

Along with the operation-maintenance manual the following documents were attached:

1. Unloading platform assembly manual