Operating and maintenance manual

Temporary Fencing Systems



Robert Cieśla
(Written by)

(Signature)

Piotr Abram
(Verified by)

(Signature)

Miłosz Muzyka
(Approved by)

(Signature)

Issue 3.0, February 2023

Table of content

1. General guidelines	4
2. Subject of the Operation and Maintenance Manual	5
3. Intended use of temporary fence systems	5
4. Risks analysis	5
5. Health and safety guidelines	5
6. List of elements	6
7. Installations	30
8. Acceptance, authorisation for use	30
9. Inspections	30
10. Maintenance	31
11. Additional information	31
12. Transport and storage	32
13. Disposal	32

Table of amendments

Pos.	Name and Last Name	Department	Date of amendment	Scope of amendment	Comments
1	Paweł Oleszkowicz	BR	26.09.2022	Descriptions update, elements list update	
2	Paweł Oleszkowicz	BR	20.02.2023	Descriptions update, elements list update	
3					
4					
5					
6					
7					
8					
9					
10					
11					
12					
13					
14					
15					

1. General guidelines

The temporary fencing system is designed to protect construction sites. The system is based on openwork and opaque fencing panels supplemented with blocks, supports, wickets and fasteners to protect the area against unauthorized access.

The subject of this technical and operational documentation (hereinafter referred to as the Operation and Maintenance Manual, OMM) is the description of the use and installation of the temporary fencing system.

The producer of the system is TLC Sp. zoo. with headquarters in 38-300 Gorlice, Chopin 25N street, Poland.

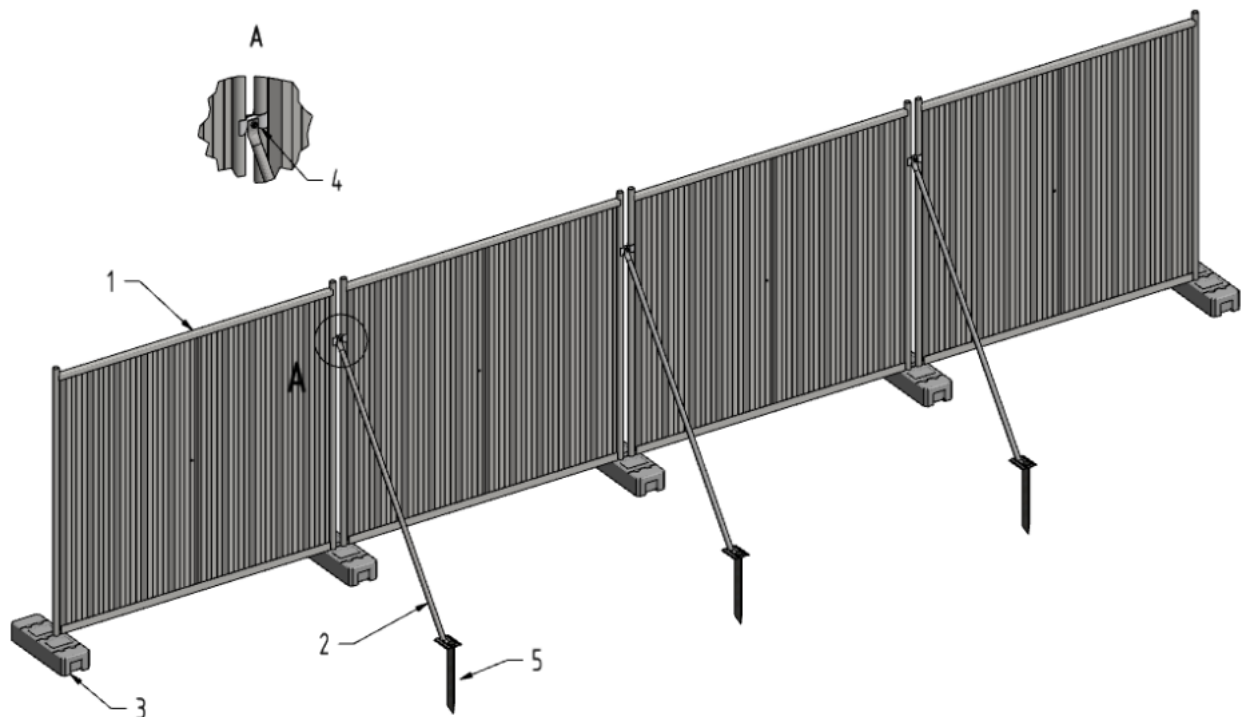

Rys. 1. Example of hoarding fence SMART;
1 - panel, 2 - support, 3 - foot, 4 - clamp, 5 - anchor

2. Subject of the Operation and Maintenance Manual

The fence panels are made of pipes and angles that form a frame, protected against corrosion by galvanizing. The frame can be filled with a mesh or a trapezoidal sheet, which in the basic version is galvanized, and at the customer's request can be coated in any color. The system is complemented by such elements as:

- concrete feet ensuring stability,
- supports increasing the stability of the fence,
- connectors/clamps for joining panels,
- gates enabling equipment access control,
- gates enabling people access control.

3. Intended use of temporary fence systems

Temporary fencing is used to separate the area and protect it from outsider. It is recommended to use panels with full filling (trapezoidal sheet), which additionally protects against noise, dust and blows of wind in dense urban buildings. On the other hand, openwork panels (mesh) are perfect for open spaces.

4. Risks analysis

Risk analysis serves to prevent hazards and reduce occupational risks associated with the assembly, use, disassembly, storage and transport of the temporary fencing system. Pursuant to the applicable regulations, such an analysis should be prepared in the form of a workplace instruction. Depending on the client's requirements, the manufacturer (TLC Sp. z o.o.) will prepare the appropriate workplace instructions including risk and threat analysis.

5. Health and safety guidelines

General provisions:

- installation of fences should be performed by qualified employees, trained in accordance with the applicable health and safety regulations,
- the manufacturer is not responsible for any damage caused by improper installation of the product or its use contrary to its intended use,
- during assembly use individual protection equipment: protective clothing, gloves, safety glasses.

6. List of elements

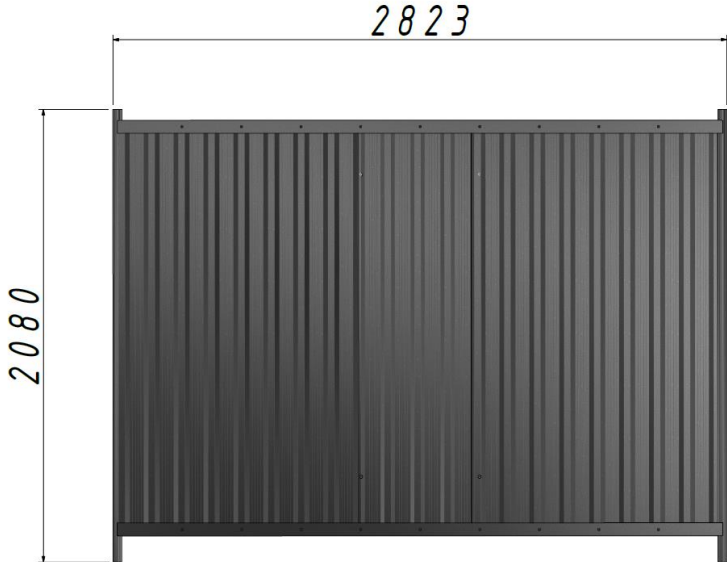
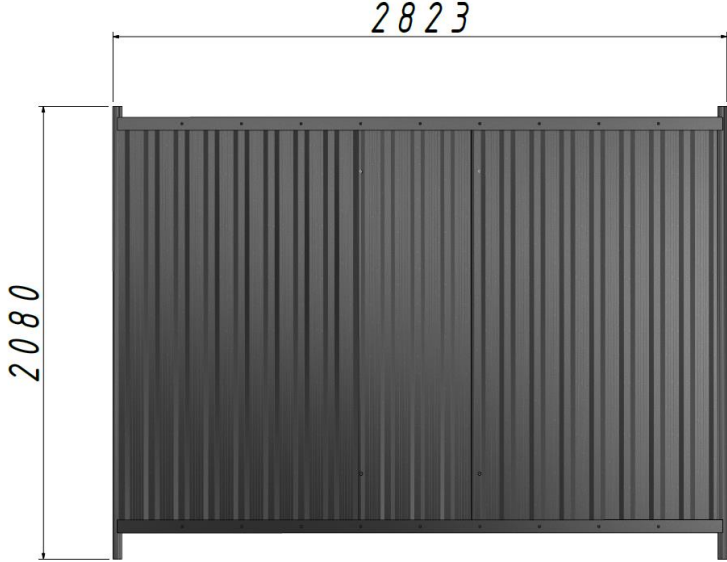
<p>OT-SL</p>  <p>Masa: 35 kg</p>
<p>OT-S</p>  <p>Masa: 39,5 kg</p>

OT-B2-ZN

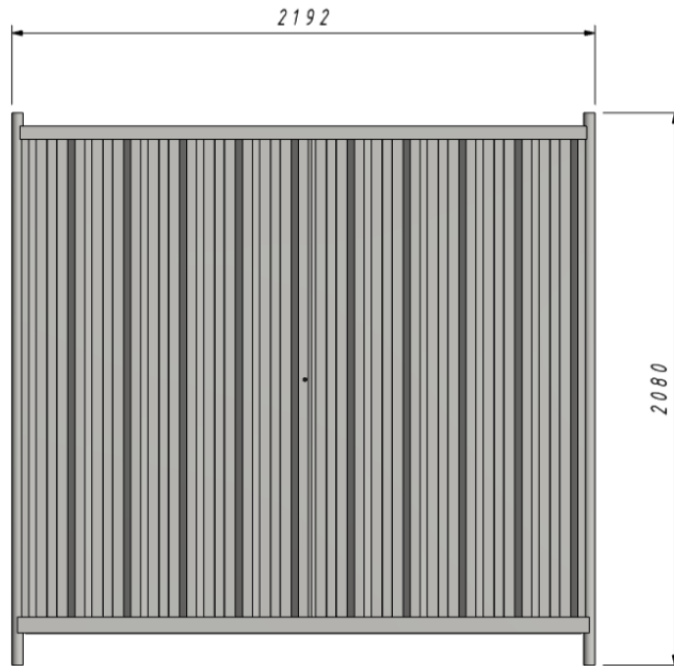

Masa: 27,5 kg

OT-MOB-M1 (OT-MOB)

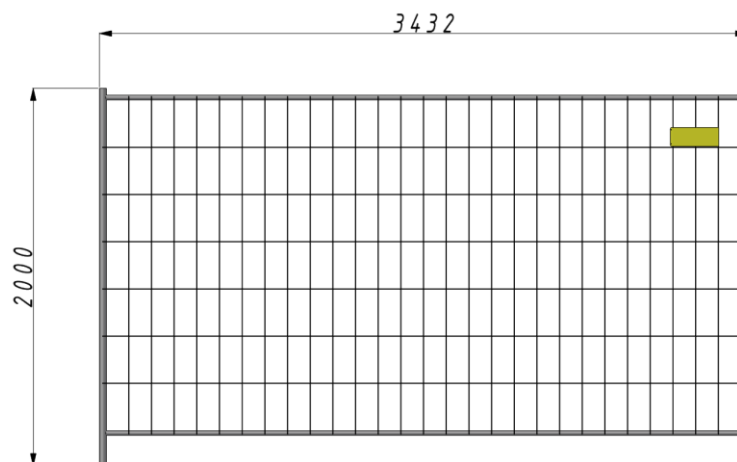

Masa: 11,5 kg

OT-MOB-M2 (OT-MOB-S)

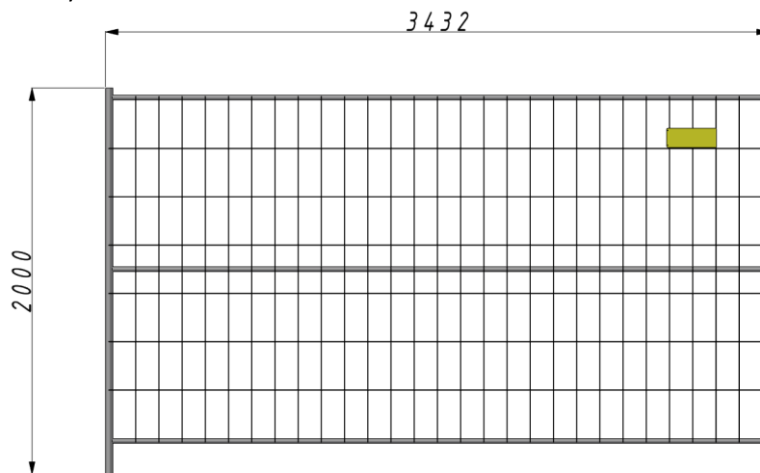

Masa: 13,5 kg

OT-MOB-M3 (OT-MOB-CB)

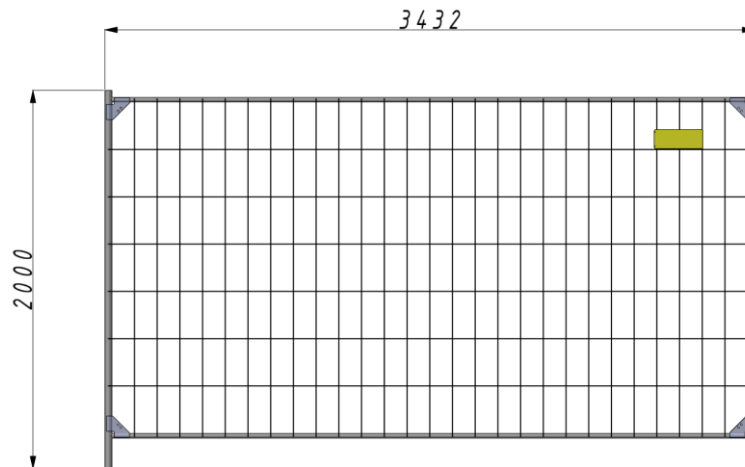

Masa: 11,7 kg

OT-MOB-M4

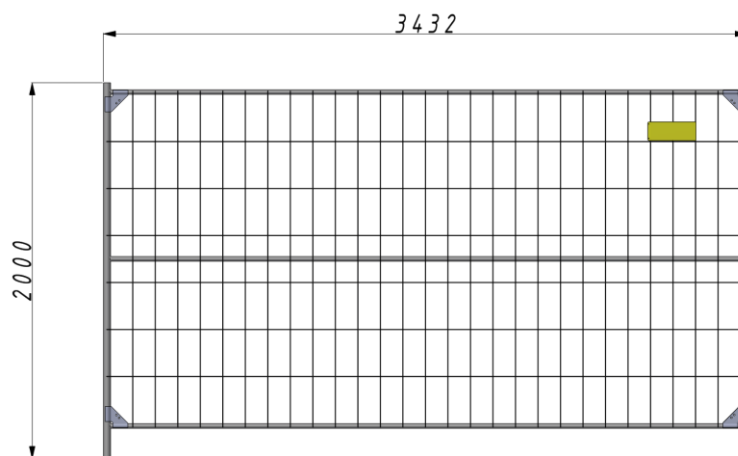

Masa: 13,8 kg

OT-MOB-M5 (OT-MOB-A)

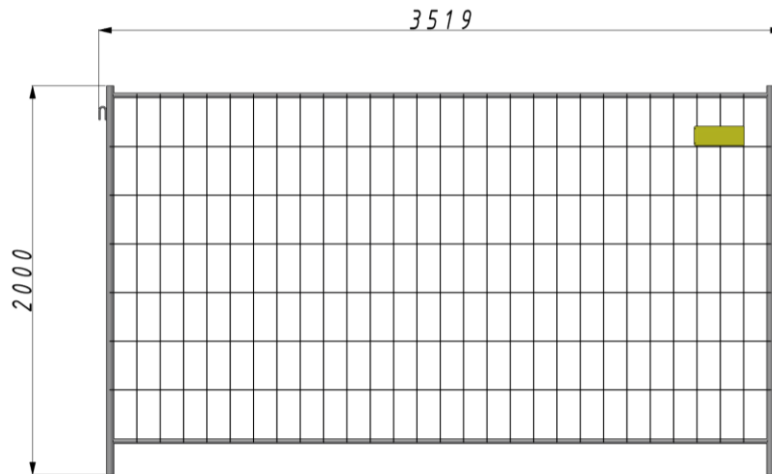

Masa: 11,6 kg

OT-MOB-M6 (OT-MOB-AC)

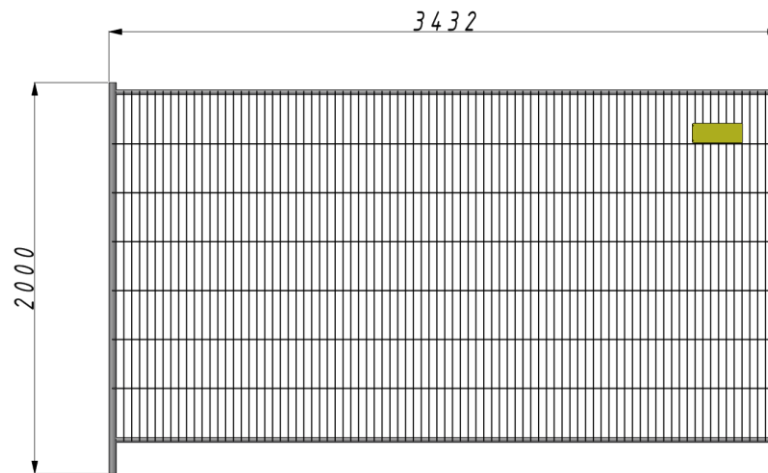

Masa: 18 kg

OT-MOB-M7

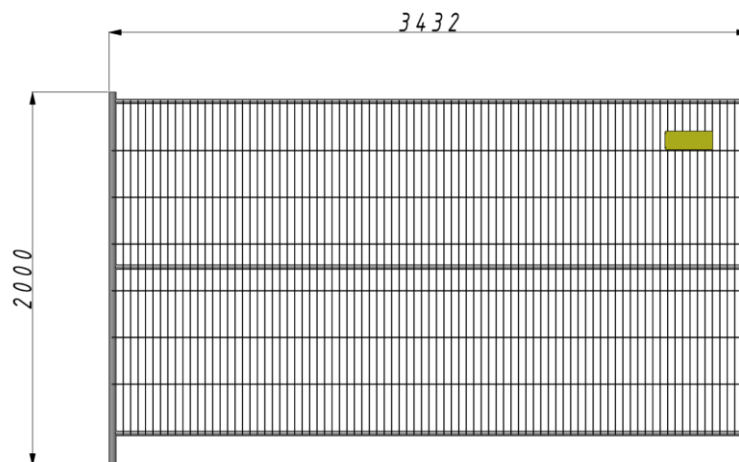

Masa: 20 kg

OT-MOB-M8

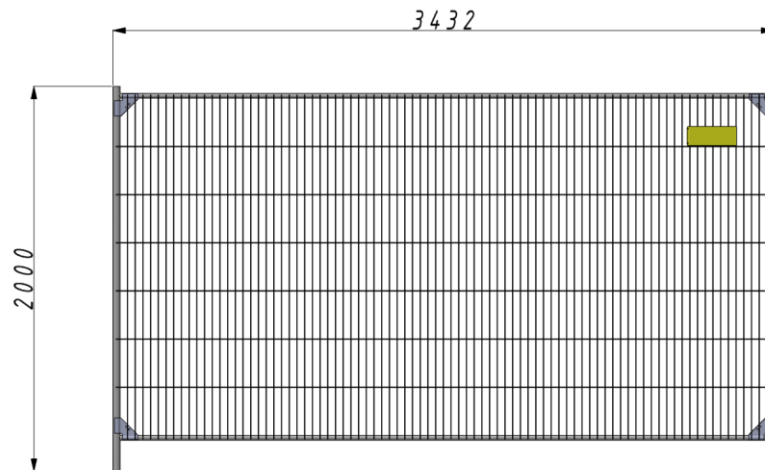

Masa: 18,2 kg

OT-MOB-M9

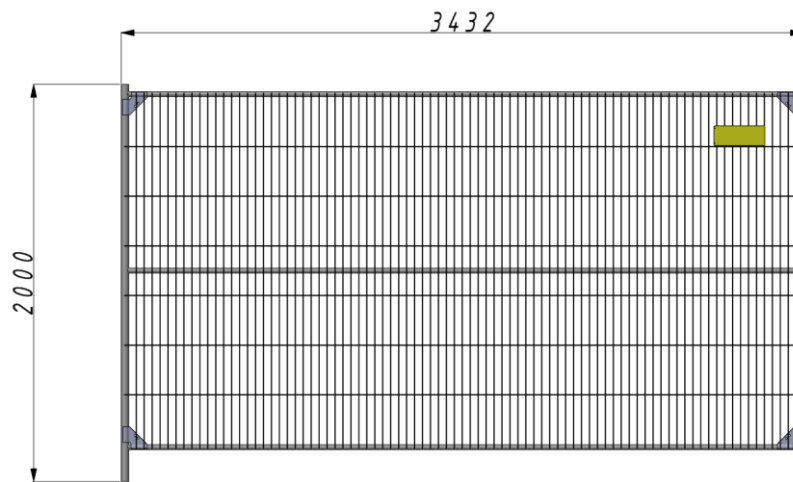

Masa: 20,2 kg

OT-MOB-M10

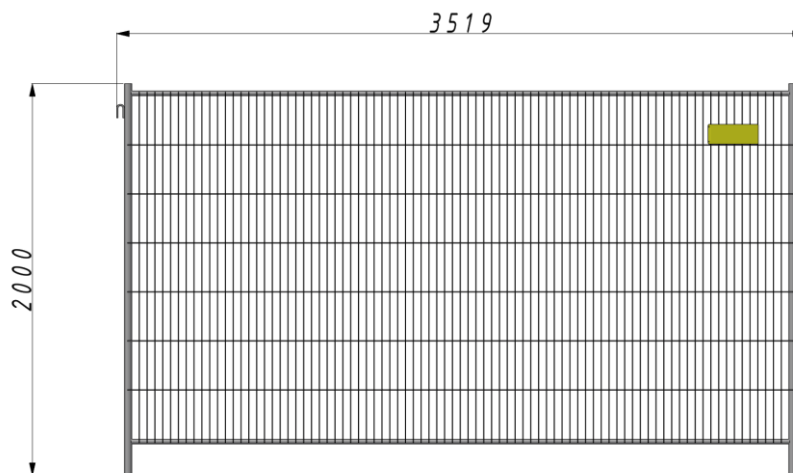

Masa: 18,1 kg

OT-MOB-P1 (OT-MOB-PRO)

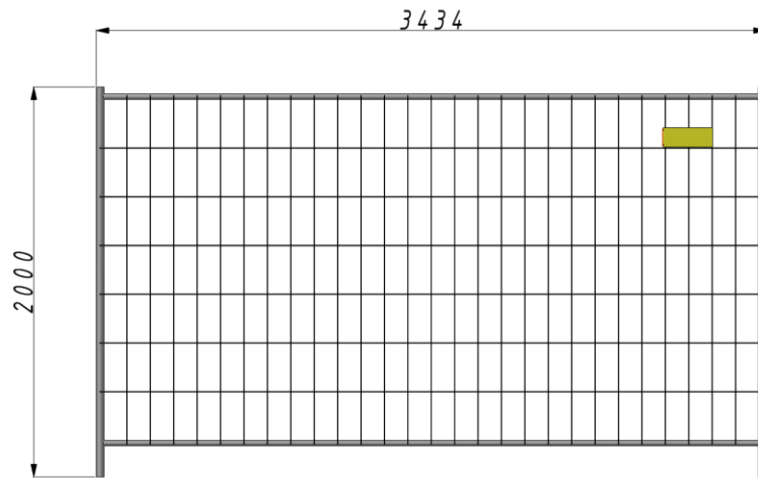

Masa: 14,7 kg

OT-MOB-P2

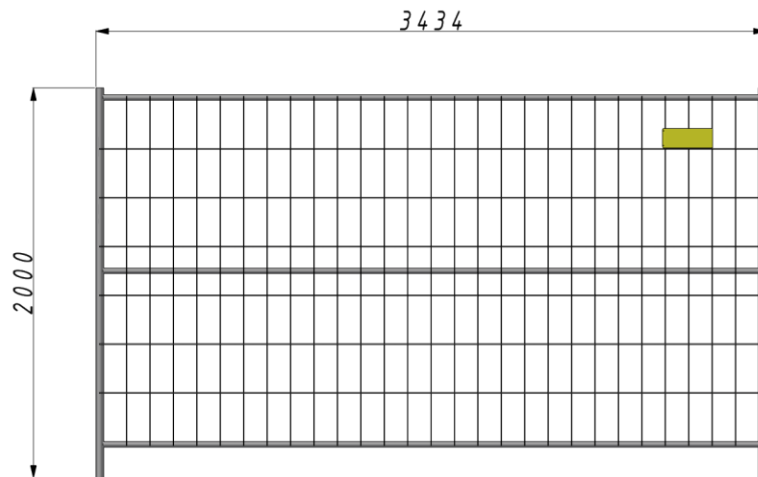

Masa: 17,4 kg

OT-MOB-P3

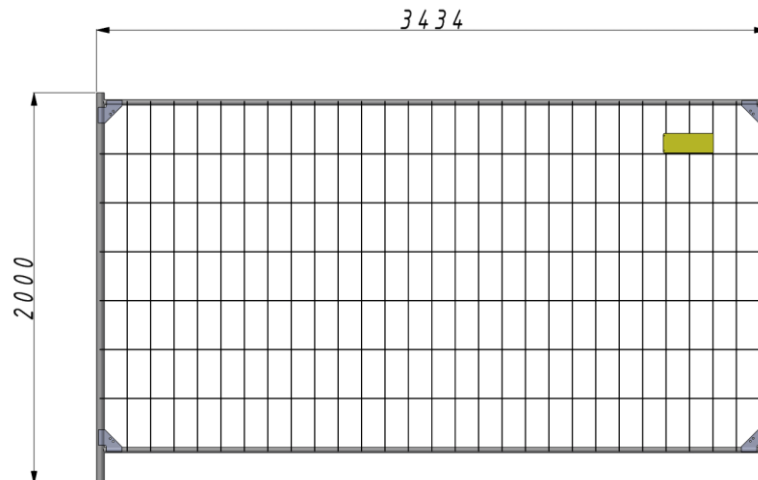

Masa: 15 kg

OT-MOB-P4 ()

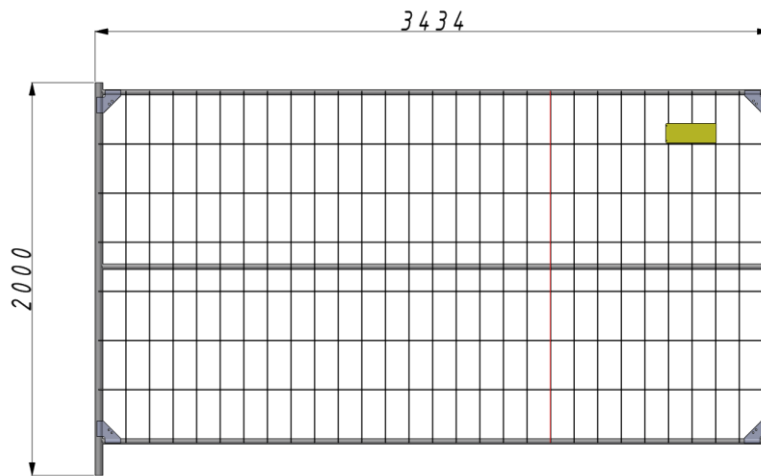

Masa: 17,7 kg

OT-MOB-P5 ()

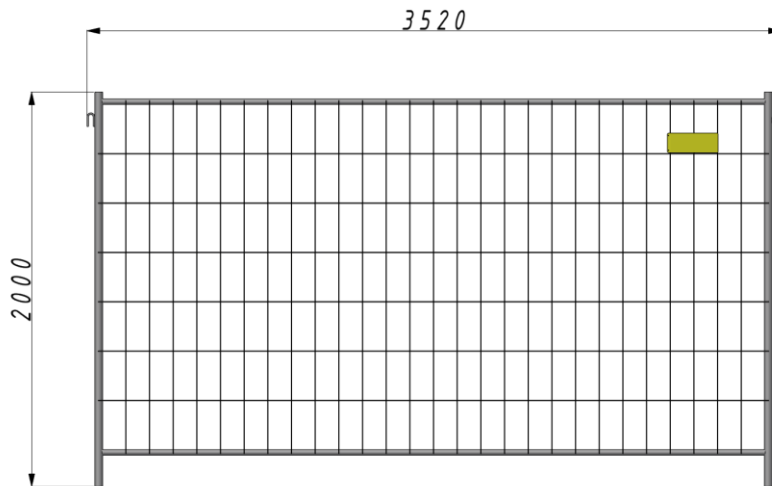

Masa: 14,9 kg

OT-MOB-RC1 (OT-MOB-G1)

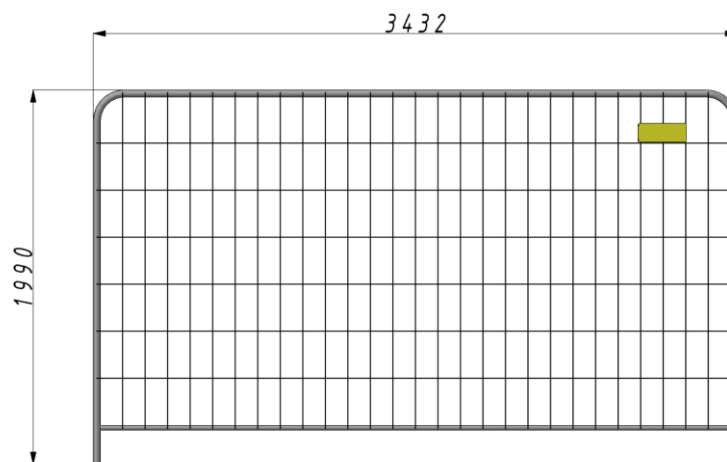

Masa: 12,5 kg

OT-MOB-RC2

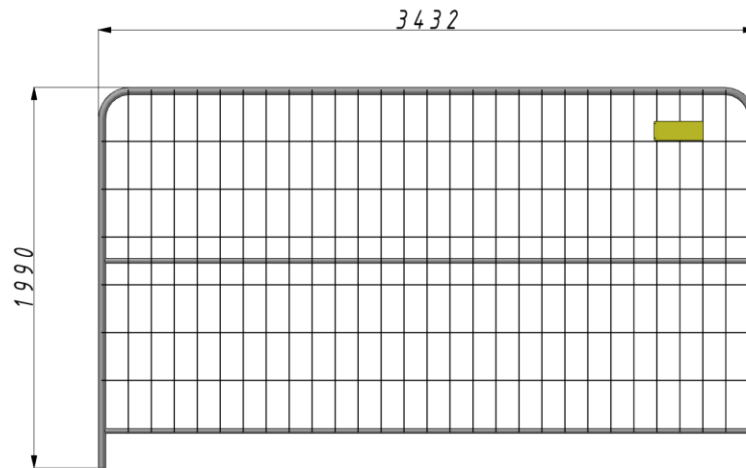

Masa: 14,5 kg

OT-MOB-RC3 (OT-MOB-G2)

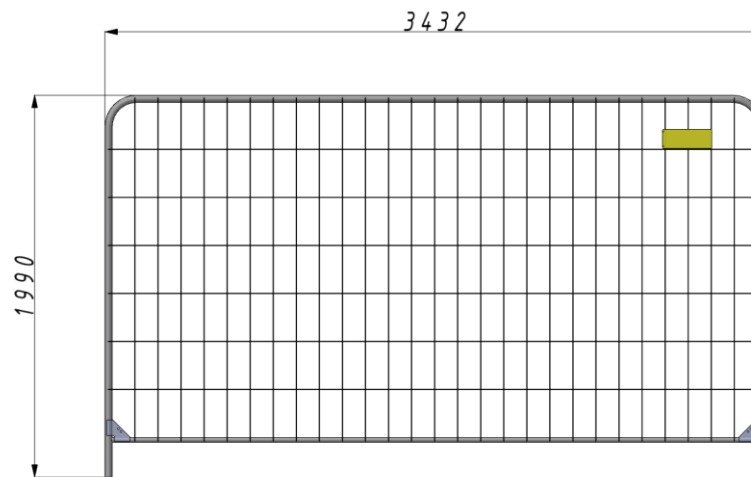

Masa: 12,6 kg

OT-MOB-RC4 (OT-MOB-GS)

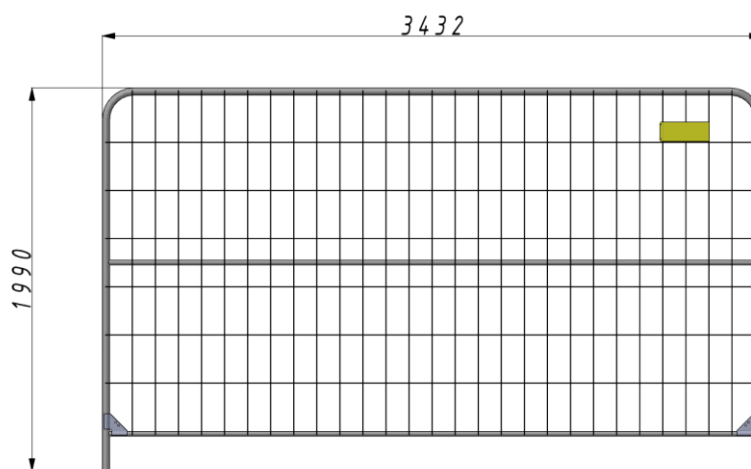

Masa: 14,6 kg

OT-MOB-RC5

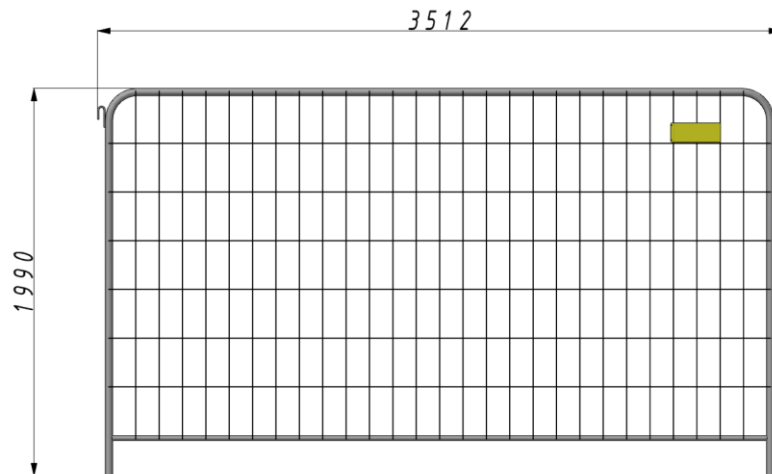

Masa: 12,6 kg

OT-MOB-RC6 (OT-MOB-G2A)

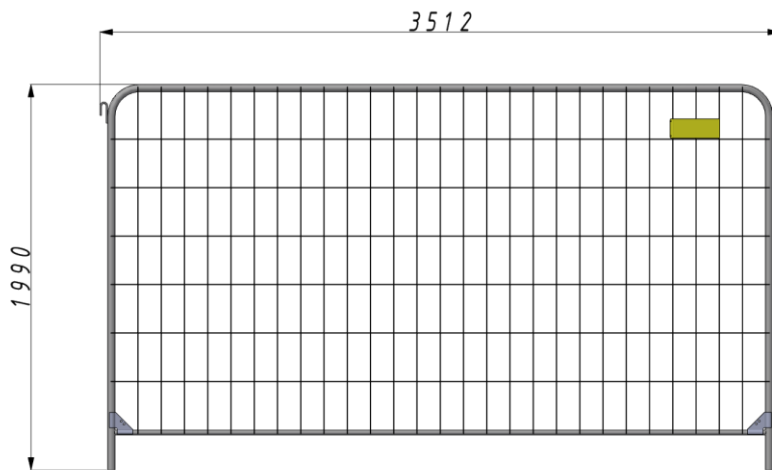

Masa: 12,7 kg

OT-MOB-RC7 (OT-MOB-RCAC)

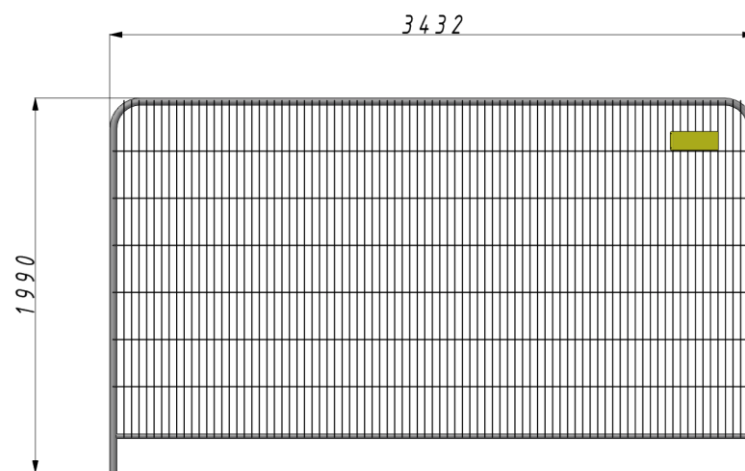

Masa: 18,9 kg

OT-MOB-RC8

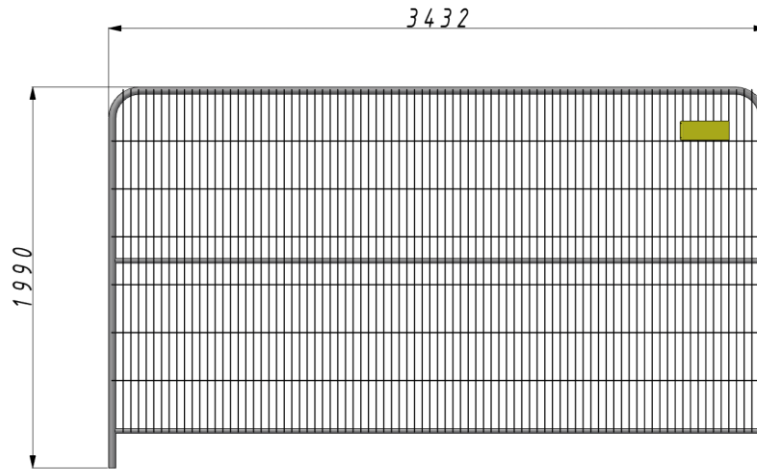

Masa: 20,9 kg

OT-MOB-RC9

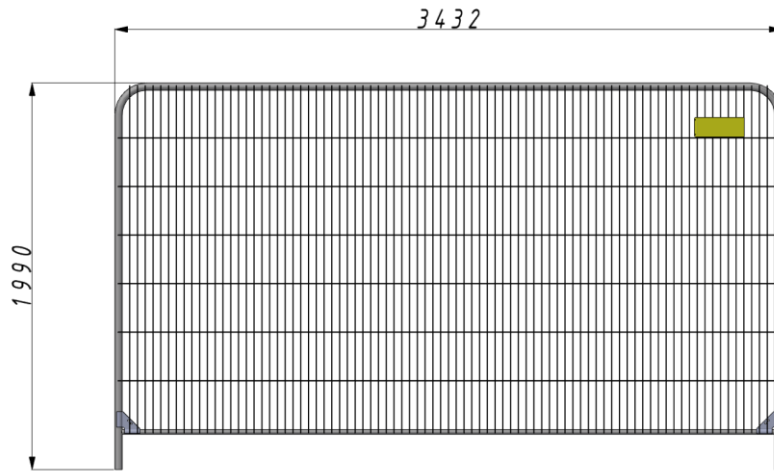

Masa: 19 kg

OT-MOB-RC10

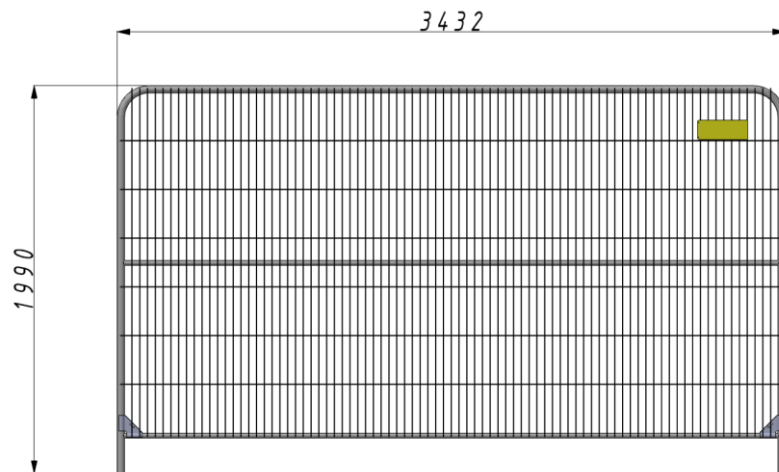

Masa: 21 kg

OT-MOB-RC11

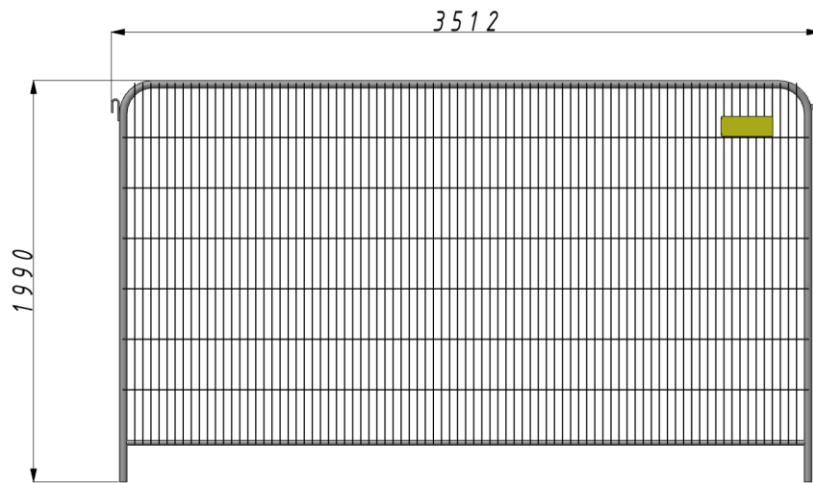

Masa: 19 kg

OT-MOB-H1 (OT-MOB-H)

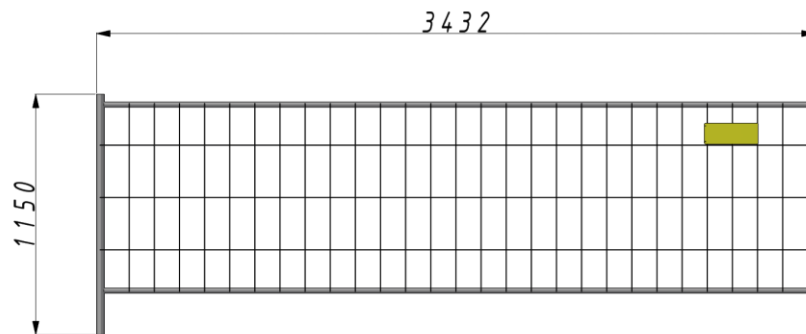

Masa: 8,2 kg

OT-MOB-H2 (G1H)

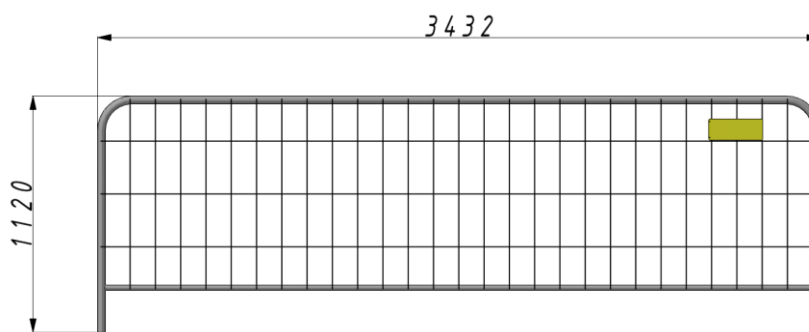

Masa: 9 kg

OT-MOB-H3 (OT-MOB-G2H)

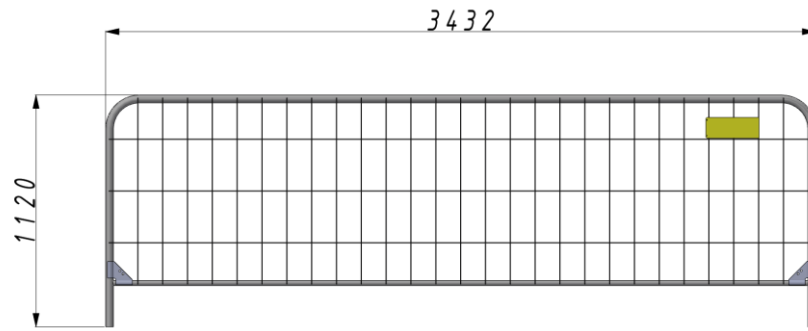

Masa: 9,1 kg

OT-MOB-H4 (OT-MOB-HA)

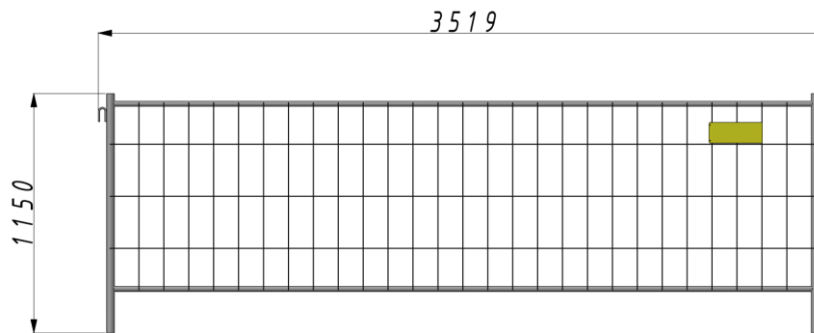

Masa: 8,3 kg

OT-MOB-H5 (OT-MOB-GHA)

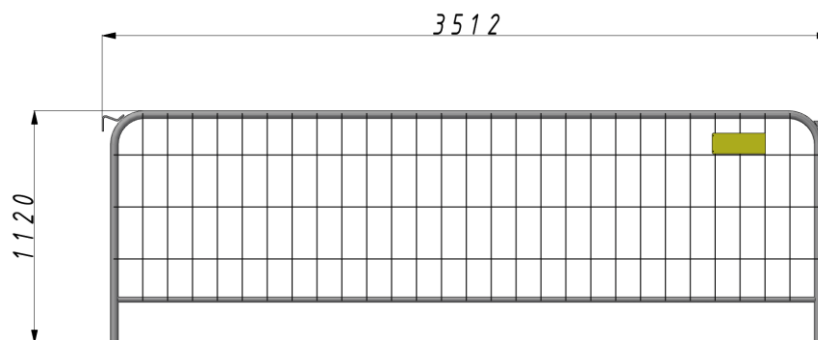

Masa: 9,2 kg

OT-MOB-HDG1 (OT-MOB-HDG)

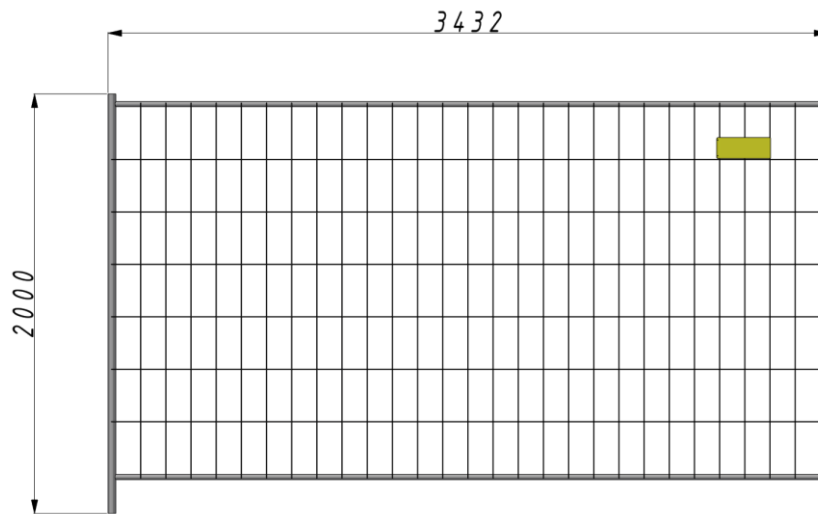

Masa: 15,2 kg

OT-MOB-HDG2 (OT-HDG-A)

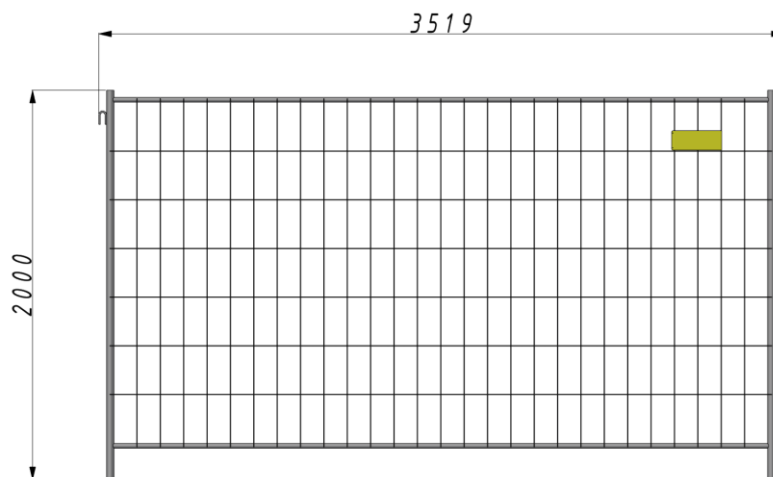

Masa: 15,3 kg

OT-MOB-HDG3

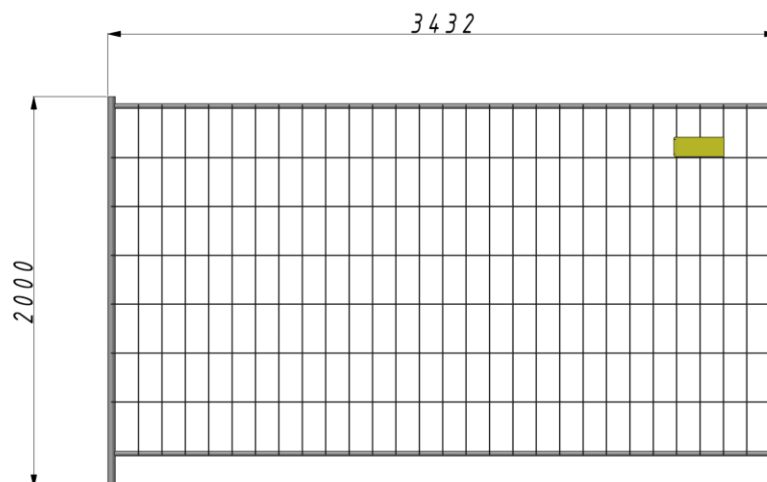

Masa: 18,2 kg

OT-MOB-HDG4 (OT-HDG-B)

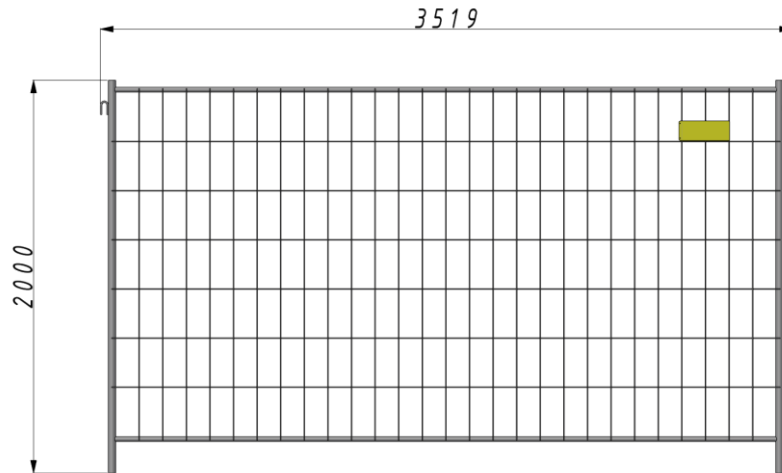

Masa: 18,3 kg

OT-MOB-F1 (P-OT-MOB-F)

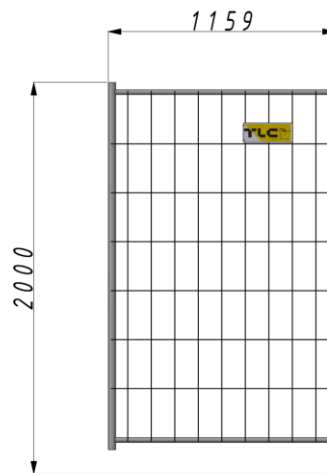

Masa: 6,6 kg

OT-MOB-F2 (OT-MOB-F2)

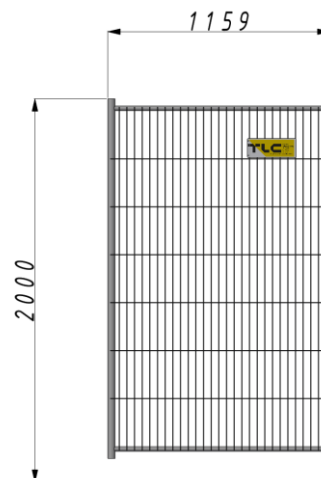

Masa: 6,6 kg

OT-MOB-F3

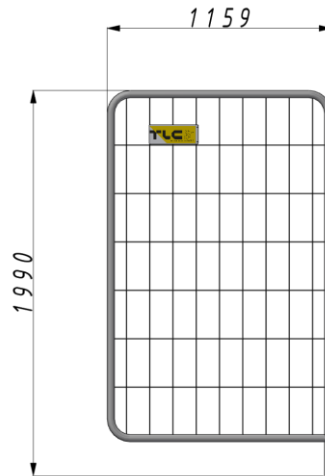

Masa: 8,4 kg

OT-MOB-F4

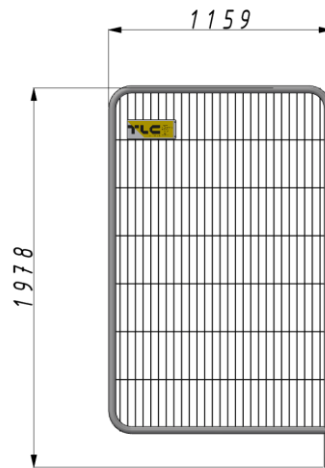

Masa: 8,4 kg

OT-FS

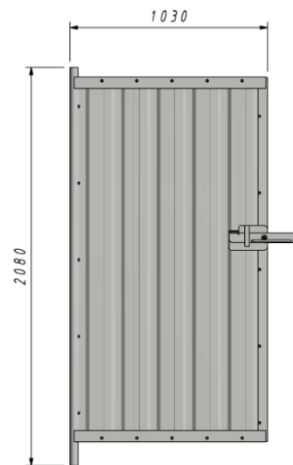

Masa: 26,4 kg

P-OT-KO

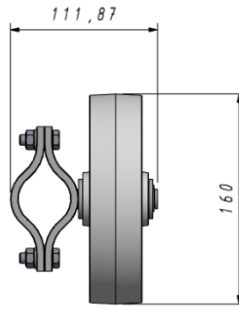

Masa: 1,2 kg

P-OT-KL-Z

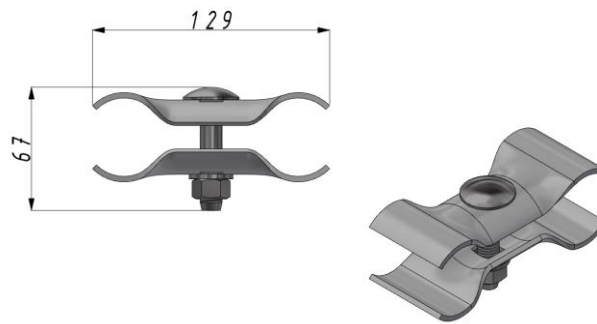

Masa: 0,35 kg

OT-002

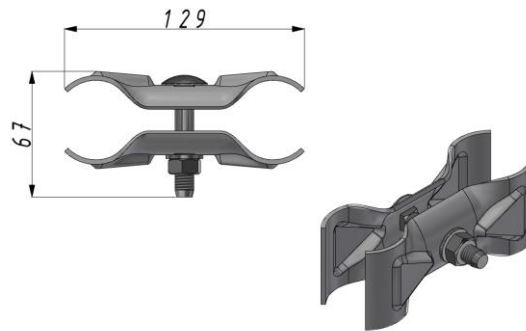

Masa: 0,3 kg

OT-KAK

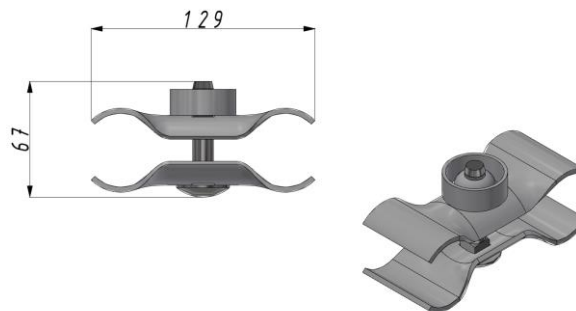

Masa: 0,36 kg

P-OT-Z

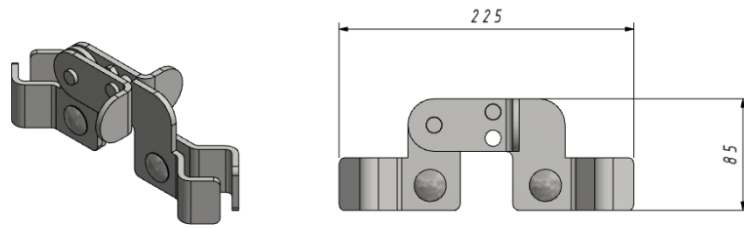

Masa: 1,3 kg

P-OT-RY1

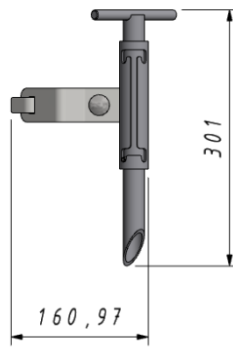

Masa: 1,2 kg

P-OT-RY2

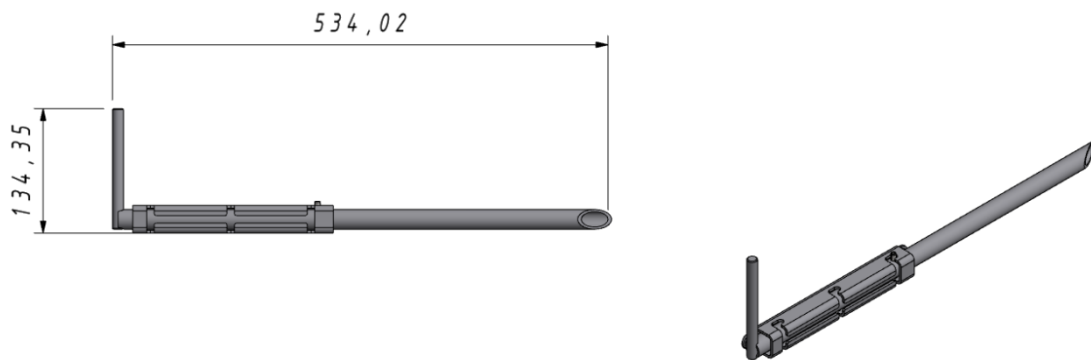

Masa: 1,1 kg

P-OT-ZA-Z

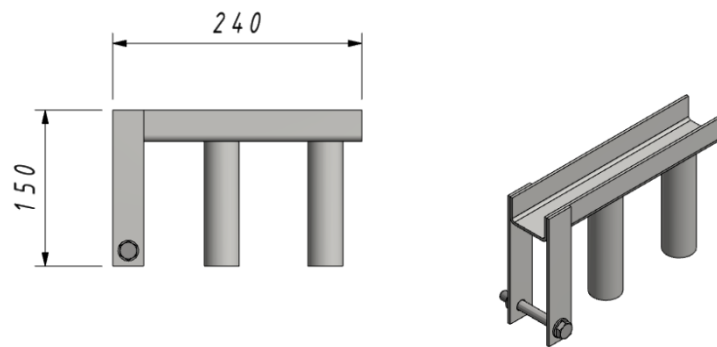

Masa: 1,2 kg

P-OT-P2

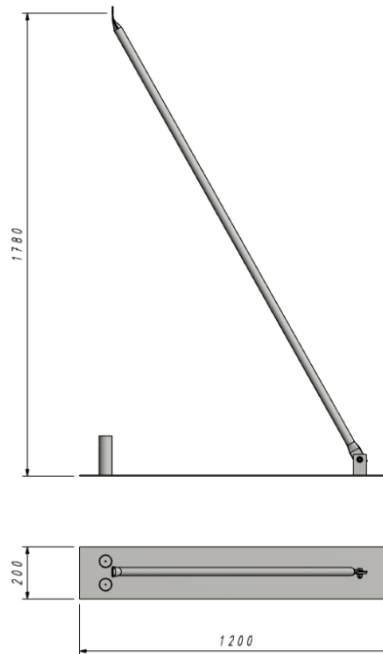

Masa: 11 kg

P-OT-P1

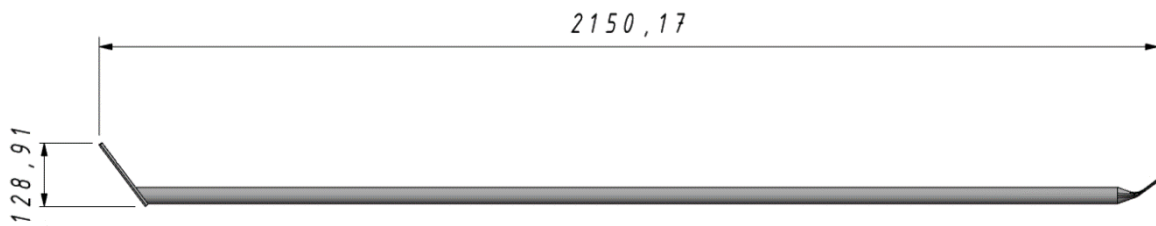

Masa: 2,8 kg

P-OT-KT-Z

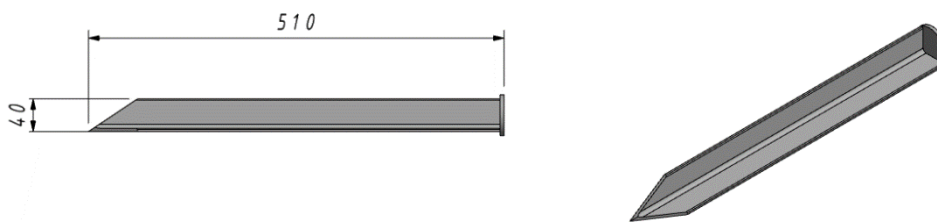

Masa: 1,2 kg

P-OT-KT2

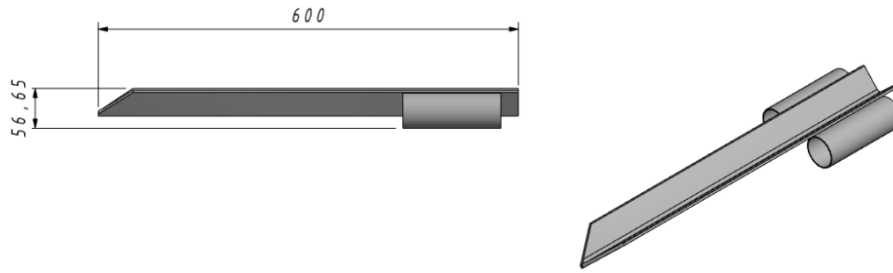

Masa: 2,6 kg

P-OT-SZ-Z

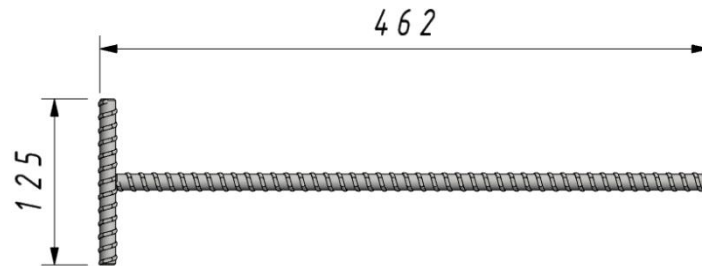

Masa: 0,7 kg

P-OT-ST24 / P-OT-ST32 / P-OT-ST36

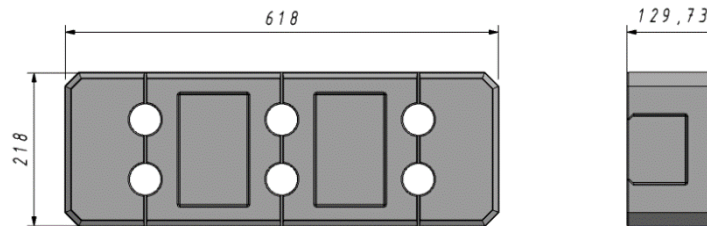

Masa: 24 / 32 / 36 kg

OT-ST18-TLC-EPS-V2

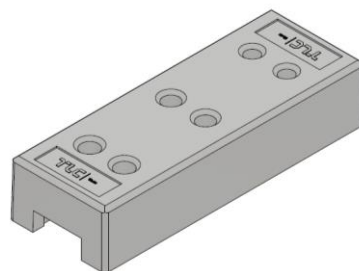
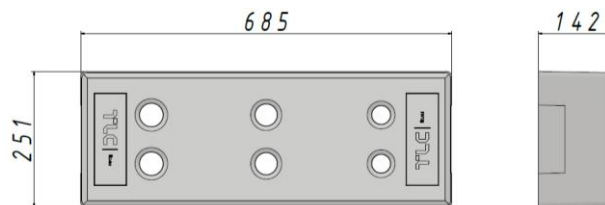

Masa: 18,5 kg

OT-RY3

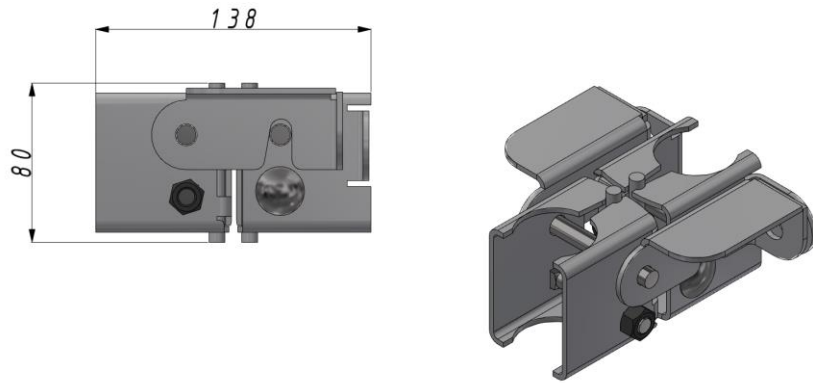

Masa: 1 kg

OT-DK

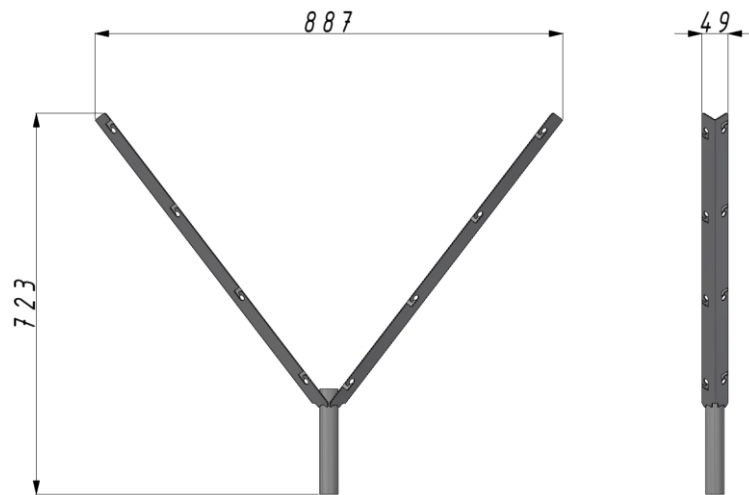

Masa: 1,7 kg

OT-DK2

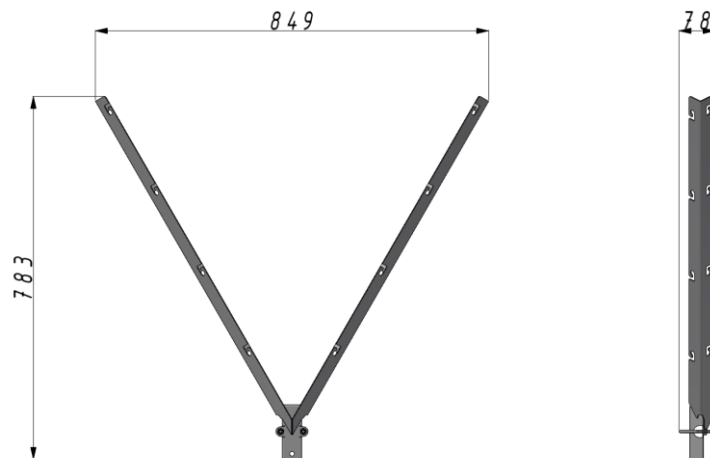

Masa: 1,79 kg

OT-BS

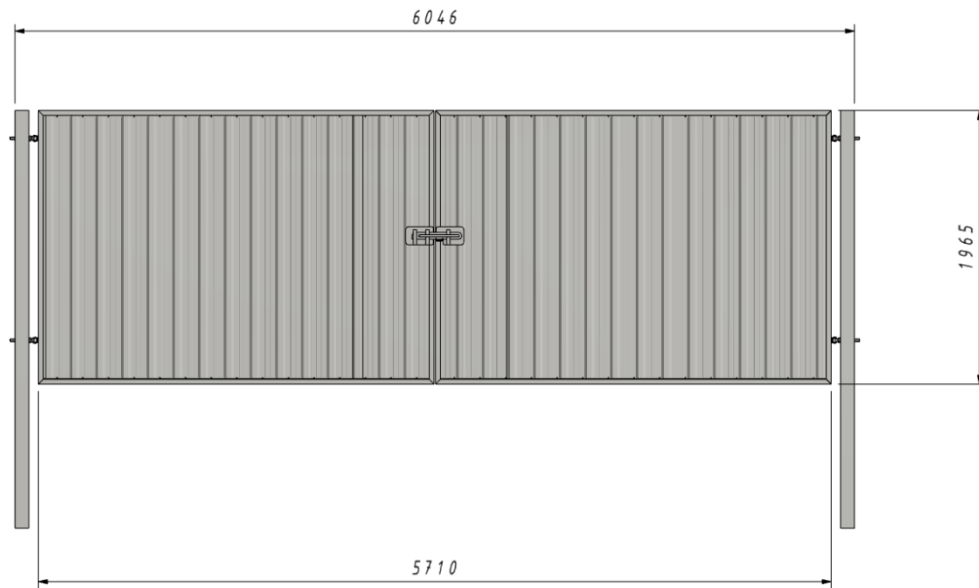

Masa: 166 kg

P-OT-BP

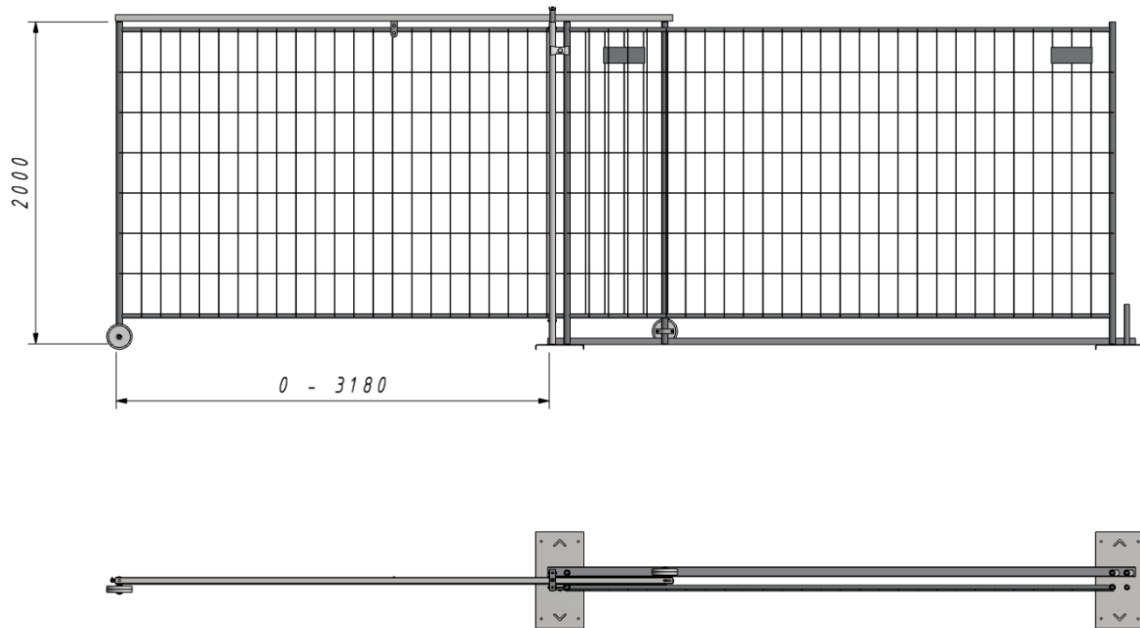

Masa: 39,4 kg

OT-PMOB

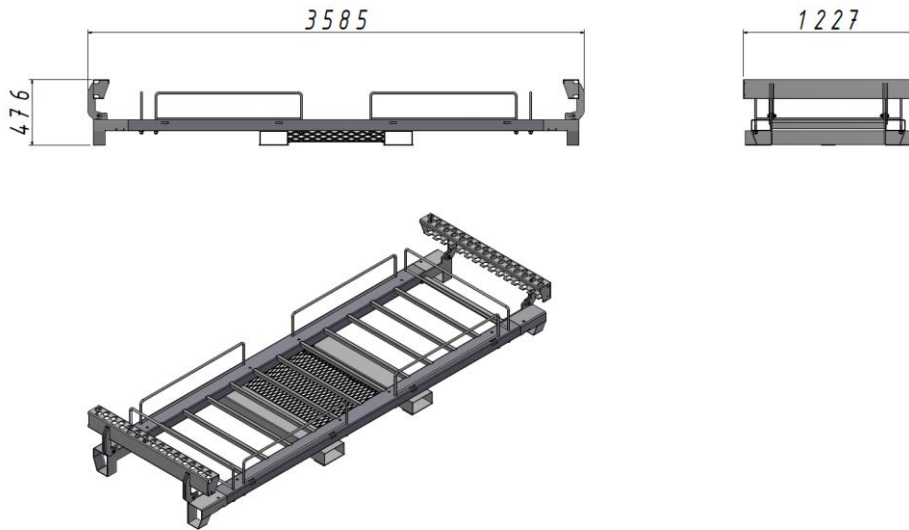

Masa: 183 kg

OT-PMOB3

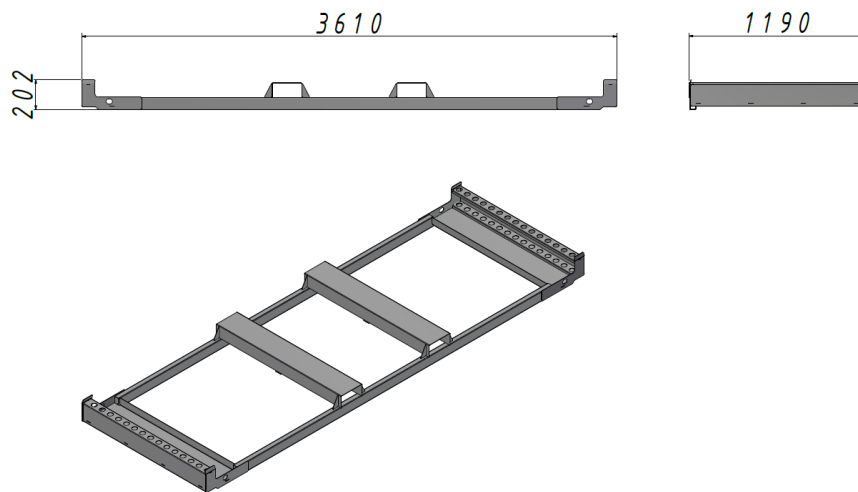

Masa: 65,5 kg

OT-PMOB4

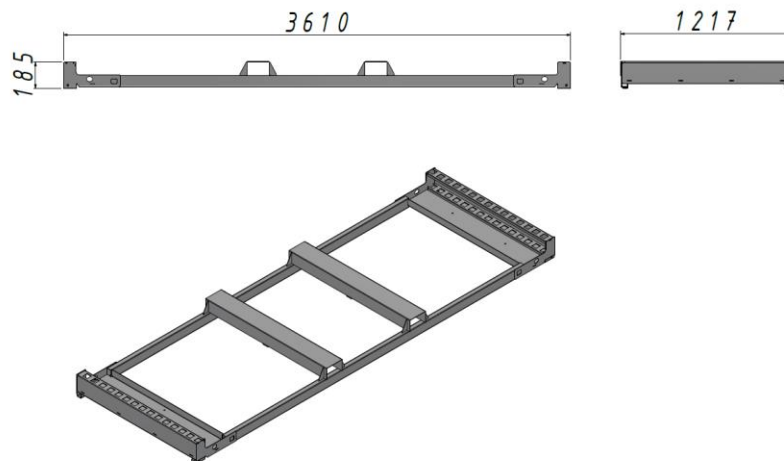

Masa: 63,4 kg

OT-PMOB05

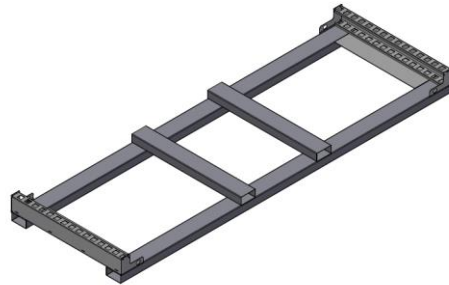
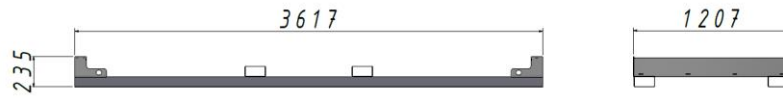

Masa: 124 kg

OT-PMOB06



Masa: 100,5 kg

OT-PMOB07

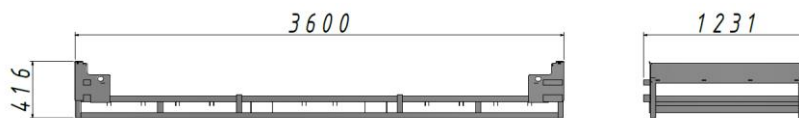

Masa: 96,3 kg

OT-PSM1

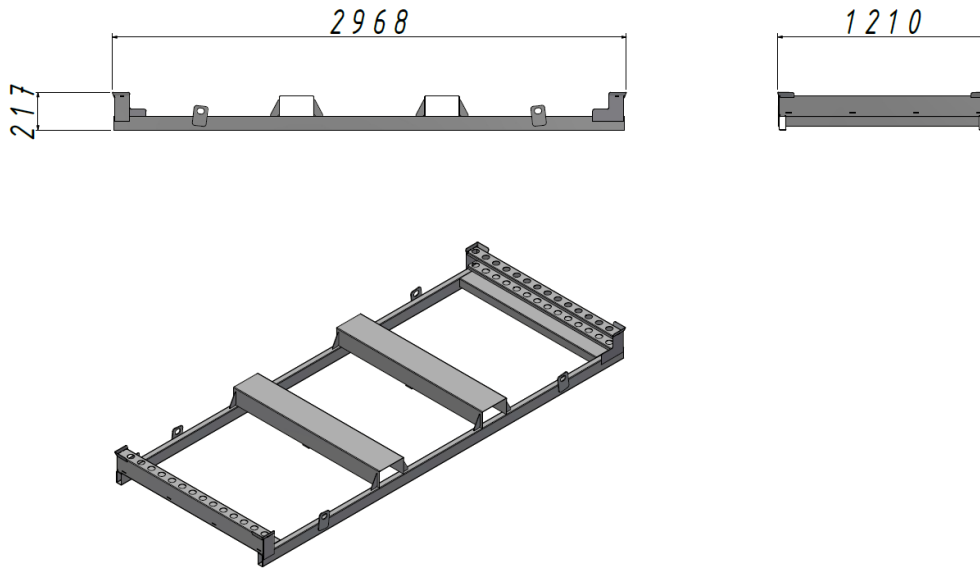

Masa: 59,5 kg

OT-SL01

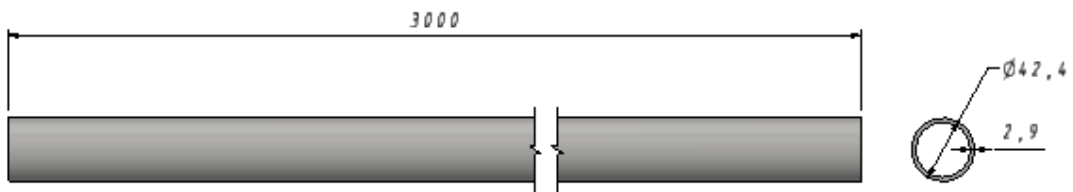

Masa: 8,5 kg

7. Installation

Before installing the fence:

- Level the ground,
- Prepare an appropriate number of elements necessary for assembly,
- Check the condition of the components.

Braces (supports) should be installed simultaneously with placing the panels on the feet.

The manufacturer, the company TLC Sp. z o.o., may conduct training in the scope of installation and use of temporary fences. The training can be carried out at the manufacturer's premises, customer's premises, place of use (construction site).

8. Acceptance, authorisation for use

Acceptance should take place after the assembly is completed with a delivery and acceptance protocol.

The operation of the temporary fencing system must be taken in accordance with the health and safety regulations, field instruction of the construction site and the manufacturer's recommendations presented below:

- read and understand this operation and maintenance manual before assembly, disassembly and transport,
- works related to the use of the system should be carried out by trained personnel,
- after installing the barrier, check the correctness of the works,
- only original parts of the system should be used,
- all system elements should be checked for faults and damage before installation,
- do not use damaged or destroyed temporary fencing system components.

9. Inspections

The following inspections should be performed:

- daily: inspected by the user of the fence (the Lessee); it's relate to fences located directly next to traffic routes, in places of intense traffic, especially of heavy equipment.
- ad hoc: is performed each time after the occurrence of phenomena that may have a negative impact on the safety of fencing operation, after each storm with a wind force exceeding 12 m/s.

The inspection should include checking that:

- the fence panels are not damaged,
- the fence is properly anchored,
- there were no phenomena having a negative impact on safety,
- condition of bolted connections.

10. Maintenance

The steel parts of the temporary fencing system are permanently protected with a zinc anti-corrosion coating in accordance with PN-EN ISO 2081 or PN-EN ISO 1461. This guarantees long-term use of the system in environmental conditions. By following the recommendations given below, you will extend the system's operation in environmental conditions. Additional tips include:

- cleaning of the system components using agents that do not damage the anti-corrosion coating,
- avoiding use of substances on the system components that damage or corrode steel and the anti-corrosion coating,
- using the system components as intended,
- not throwing system elements,
- hitting the system components, if necessary, through shock-absorbing materials: elastomers (rubber), wood, etc.,
- proper storage of system components,
- avoiding external weather conditions such as rain or snow during storage.

11. Additional information

TLC Sp. z o.o. reserves the right to amend and improve the products as required. This publication describes the state of the product at the time of its release and may differ from later versions of the product.

TLC Sp. z o.o. does not provide any guarantees or warranties, including contractual and any resulting from applicable law, for the use of the temporary fencing system in a manner inconsistent with its intended use.

TLC Sp. z o.o. is not responsible for random accidents during installation resulting from failure to comply with health and safety regulations and failure to take into account the conditions of zoning plan and media layout in the place of installation of the fence. This applies both to the route of utilities

running in the ground and on the surface (e.g.: water and sewage installations, gas installations, electrical installations, transmission media, etc.).

TLC Sp. z o.o. recommends reading the zoning plan before proceeding with the installation of the temporary fencing system.

TLC Sp. z o.o. informs that the client must indicate the location of the temporary fencing system prior to installation.

In the event of a failure of the temporary fencing system, the customer is liable for any damage caused during operation if:

- the place of installation of the system was given incorrectly,
- the place of installation of the system has not been specified at all.

TLC Sp. z o.o. is also not liable for damage to persons and property at the user and third parties as a result of improper use of the temporary fencing system specified in this publication.

12. Transport and storage

Fence panels should be stored and transported in an upright position.

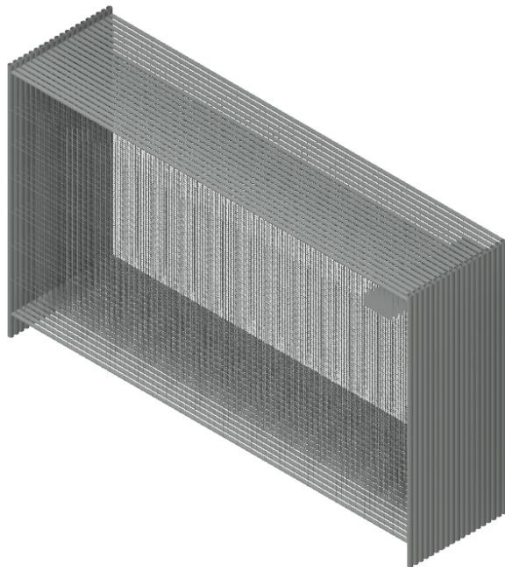

13. Disposal

Damaged elements can be repaired by the manufacturer after agreeing the terms with the customer. Defective parts that cannot be repaired must be disposed of in accordance with local regulations.