

SPIRAL STAIRS

Assembly manual



Table of Contents

1.	Assembly manual	4
2.	Spiral stairs elements	4
	Table 1. Elements	4
	Table 2. Connectors elements	6
	Table 3. Spiral stairs elements	6
3.	Spiral stairs assembly - list of tools	10
	Table 4. Tools	10
4.	The order of spiral stairs assembly	10
4.1.	Central pipe foot assembly	10
4.2.	Proper use of hammer bolts	11
4.3.	Platform-to-pipe assembly	13
4.4.	Central pipe assembly	14
4.5.	Steps assembly	15
4.6.	Railings assembly	17
4.7.	Multilevel stairs*	24
4.8.	Spiral stairs grating cage assembly**	25
4.9.	Grating cage assembly	27

Table of changes

No	NAME	DEPT	DATE OF CHANGE	SCOPE OF CHANGE	REMARKS
1	Piotr Mruk	K-T	15-17.03.2017	New construction set up, addition of elements list and table of change, connectors and assembly elements, graphics, update of the instruction content in accordance to the new spiral stair elements.	
2	Piotr Mruk	K-T	20.03.2017	All graphics edition because of the new elements update of the connectors and their symbols.	
3	Piotr Mruk	K-T	30.03.2017	Update of hinges L1 replaced by L2, update of graphics and tables, additional graphics: lock plate on the door, connection of the pole R1 to the ground, R2 to the ground and to a step.	
4	Piotr Mruk	K-T	08.02.2018	System elements have been updated, adding new and updating current system components, adding and updating current graphics and descriptions. Updating document header and footer.	
5	Miłosz Muzyka	BR	04.07.2018	Adjustment of montage order to currently used handgrip solution	
6	Piotr Abram	B-R	26.10.2018	Pos. 4.2, 4.2 – change of steps/landings connection to the central pipe	
7	Miłosz Muzyka	BR	18.03.2020	Change in general instruction for hammer bolts	

1. Assembly manual

Assembly instruction is the appendix for technical and operational documentation of TLC spiral stairs.

Spiral stairs consist of particular elements in accordance to the delivery specification. Parts are assembled using bolted connections. Product is delivered as separate elements such as platforms, steps, connectors, gates and post. Elements should be assembled in accordance to proper order.

Spiral stairs can have any height and radius in the range between 550mm and 1500mm (radius increase every 50mm), depending on the needs.

2. Spiral stairs elements

List of elements in Table 1 shows spiral stairs elements and their quantity, determined depending on individual customer order.

Spiral stairs elements marking system:

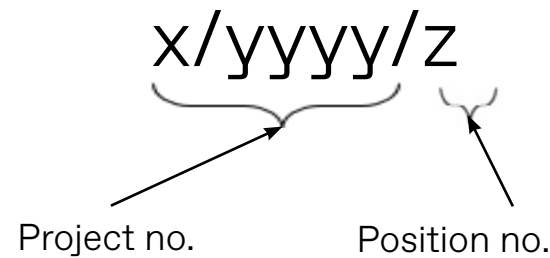

In case of handrails:

- spiral handrails are marked „H” in such a way:
 - first bottom part of handrail has got marking: x/yyyy/z/H-1
 - The last part of handrail before the last stairs platform has the following marking: x/yyyy/z/H-nn,

where:

- x – year
- yyyy – project number
- z – project part (subproject)
- nn – calculated amount of required handrail’s parts

- handrails on platforms, slabs, etc. – are marked „HL” eg. x/yyyy/z/HL-1.

Table 1 Elements.

SPIRAL STAIRS LIST OF ELEMENTS			
No.	Element	Marking/Symbol	Weight [kg]
1	CENTRAL PIPE	S-1	according to the order
2	CENTRAL PIPE FOOT	M-D-A-1 (A,B,C,D)	according to the order
3	FIRST RAILPOST FOOT	M-D-A-6 or A-6	0,28
4	SPIRAL HANDRAIL	H-n	according to the order
5	STRAIGHT HANDRAIL	HL-n	according to the order
6	WALL FIXING	C-n	according to the order
7	WALL FIXING CONSOLE	M-D-A-3	1,46
8	WALL FIXING CLAMP	M-D-OBJ-N	1,11

PLATFORM			
9	PLATFORM (FILLING ACCORDING TO THE ORDER)*	M-1 ... M-n	
STEPS			
10	STEP (FILLING ACCORDING TO THE ORDER *)	S-SP-xxxx -xxx-xxxx	
CHILDREN-SAFE RAILING - RAIL POSTS			
11	STARTING RAIL POST	R-1	2,73
	STAIR RAIL POST	R-n	3,54
	STARTING RAIL POST (for R>1250)	R-2A	2,76
	STAIR RAIL POST (for R>1250)	R-nA	3,62
	PLATFORM RAIL POST	R-n	2,51
INDUSTRIAL RAILING - RAIL POSTS			
12	STARTING RAIL POST	R-1	1,99
	STAIR RAIL POST	R-n	1,96
	PLATFORM RAIL POST	R-n	1,82
ENTRANCE PROTECTION ELEMENTS			
13	GATE	D-1	27,3
14	DOOR FRAME	D-2	19,3
15	HINGE	M-D-Z-3	0,24
CONNECTORS			
16	CAGE CONNECTOR	M-D-OS-L-2	0,37
	CAGE CONNECTOR	M-D-OS-L-3	0,21
	CAGE CONNECTOR	M-D-OS-L-4	0,20
17	CONNECTOR	M-D-A-7	0,96
GRATING CAGE			
18	GRATING PANEL	P-1	according to the order
	GRATING PANEL	P-2	
	GRATING PANEL	P-3	
	GRATING PANEL	P-4	
	GRATING PANEL	P-5	
	GRATING PANEL	P-6	
	GRATING PANEL	P-7	
	GRATING PANEL	P-8	
	GRATING PANEL	P-9	

Steps index/markings depends on the ordered surface.

W-S-SP-xxxx-xxx-xxxxx



A. B. C. D.





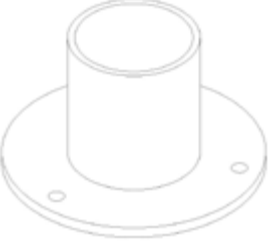

- A. Index prefix
- B. Step (stairs) radius
- C. Step surface
 - KR – press-welded grating
 - KRS – serrated press-welded grating
 - KRP – profiled grating
 - BLR – tear (durbar) plate
- D. Size of grating eye (for KR and KRS options)

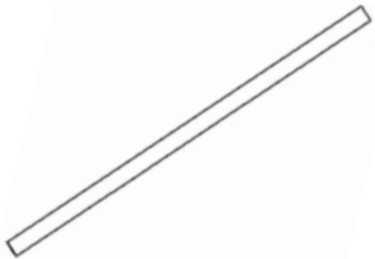

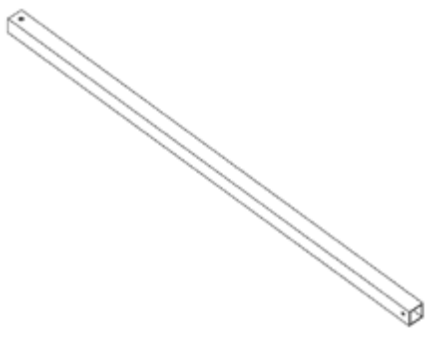
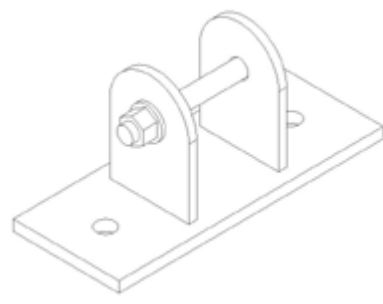
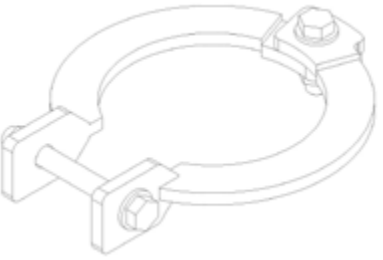
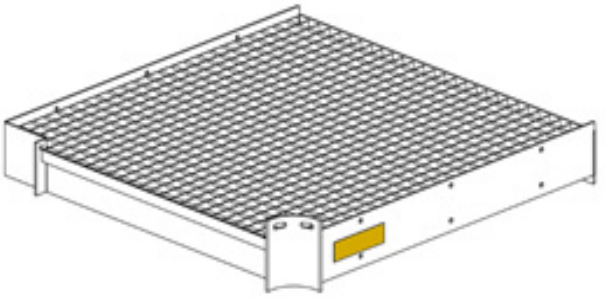
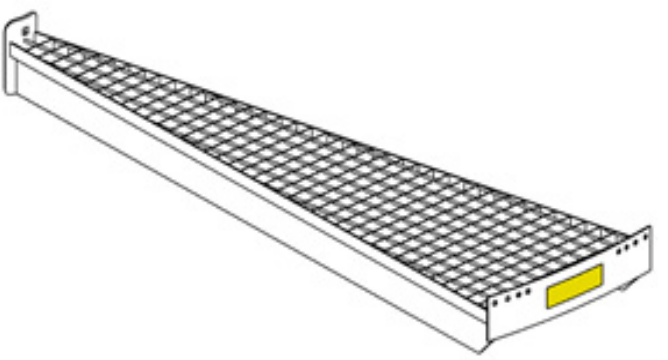
Table 2. Connecting elements.

No.	Element	Marking/Symbol	Weight [kg]
A	Carriage bolt x M10 x 50 cl. 8.8 hot-dip galvanized	Bolt M10 x 50	0,039
B	Threaded rod DIN975 M12 x 200 cl. 8.8 hot-dip galvanized (out of delivery scope)	Rod M12 x 200	0,138
C	Hammer head bolt with square neck DIN 186 12x35 cl. 8.8 electro-galvanized/hot-dip galvanized	Hammer bolt M12 x 35	0,068
D	Hexagon bolt M8x25 cl. 8.8 Zintek	Bolt M8 x 25	0,022
E	Hexagon nut M8 cl. 8 Zintek / hot-dip galvanized	Nut M8	0,006
F	Hexagon nut M10 cl. 8 hot-dip galvanized	Nut M10	0,011
G	Hex nut M12 cl. 8 hot-dip galvanized	Nut M12	0,016
H	Nylon Insert Hex Lock Nut M12 cl. 8 hot-dip galvanized	Lock Nut M12	0,018
I	Self-drilling screw 4,2x16 electro galvanized	Screw 4,2x16	0,005
J	Washer M8 hot-dip galvanized	Washer 8	0,002
K	Washer M10 hot-dip galvanized	Washer 10	0,004
L	Washer M12 hot-dip galvanized	Washer 12	0,006
M	Grating fixing G-11	G-11	0,150
N	Locking washer 12 (plastic)	Locking washer 12	0,001
O	Locking washer 12 (metal)	Locking washer 12	0,001
P	Chemical anchor	Chemical anchor	-
R	Plastic cap for pipe 42,4	42,4 plastic cap	0,03
S	Plastic cap for 30x30 square hollow section	30x30 plastic cap	0,02
T	Plastic cap for pipe 127	127 plastic cap	0,15
U	Hexagon bolt M10x40 cl. 8.8 hot-dip galvanized	Bolt M10x40	0,031

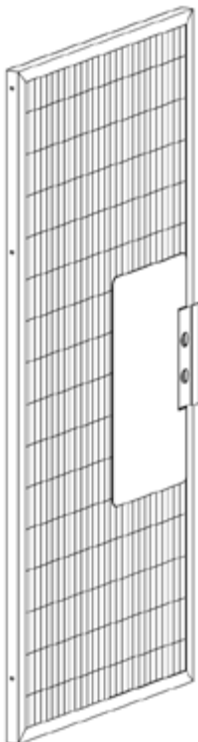

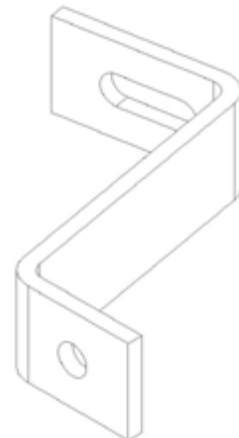
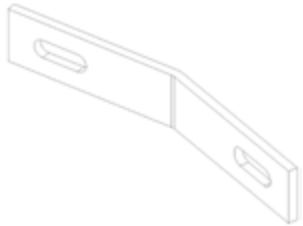

Table 3. Spiral stairs elements.





PIPE x/yyyy/z/ S-1... S-n	CENTRAL PIPE FOOT M-D-A-1 (A,B,C,D) or x/yyyy/z/A-1	FIRST RAIL POST FOOT M-D-A-6
		
	Position. 2	Position. 3
	SPIRAL HANDGRIP x/yyyy/z/H-n	STRAIGHT HANDGRIP x/yyyy/z/HL-n
Position. 1	 Position. 4	 Position. 5

WALL FIXING x/yyyy/z/C-1	WALL FIXING CONSOLE M-D-A-3	WALL FIXING CLAMP M-D-OBJ-N		
				
Position. 6	Position. 7	Position. 8		
PLATFORMS (TYPE OF FILLING ACCORDING TO THE ORDER)* x/yyyy/z/M-1		STEP (TYPE OF FILLING ACCORDING TO THE ORDER)* S-SP-xxxx -xxx-xxxxx		
				
Position. 9		Position. 10		
CHILDREN-SAFE RAILING				
STARTING RAIL POST x/yyyy/z/R-1	STAIR RAIL POST x/yyyy/z/R-n	STARTING RAIL POST (for R>1250) x/yyyy/z/R-2A	STAIR RAIL POST (for R>1250) x/yyyy/z/R-nA	PLATFORM RAIL POST x/yyyy/z/R-n
				
Position. 11				

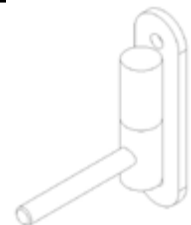
CHILDREN-SAFE RAILING		
STARTING RAIL POST x/yyyy/z/R-1	STAIR RAIL POST x/yyyy/z/R-n	PLATFORM RAIL POST x/yyyy/z/R-n
		

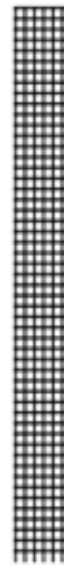

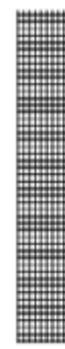
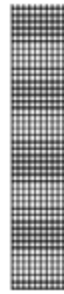
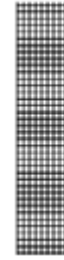
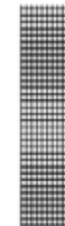
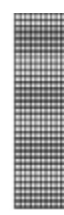

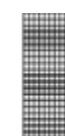

Position. 12

CHILDREN-SAFE RAILING			
GATE / DOOR LEAF x/yyyy/z/D-1	DOOR FRAME x/yyyy/z/D-2	CAGE CONNECTOR M-D-OS-L-2	CAGE CONNECTOR M-D-OS-L-3
			
		CAGE CONNECTOR M-D-OS-L-4	
			
		Position. 15	
		DOOR FRAME CONNECTOR M-D-A-7	HINGE M-D-Z-3
			
Position. 13	Position. 14	Position. 16	Position. 17

GRATING CAGE		
GRATING PANEL x/yyyy/z/P-1	GRATING PANEL x/yyyy/z/P-2	GRATING PANEL x/yyyy/z/P-3
		
GRATING PANEL x/yyyy/z/P-4	GRATING PANEL x/yyyy/z/P-5	GRATING PANEL x/yyyy/z/P-6
		
GRATING PANEL x/yyyy/z/P-7	GRATING PANEL x/yyyy/z/P-8	GRATING PANEL x/yyyy/z/P-9
		
Position. 18		

3. Spiral stairs assembly - list of tools

Table 4. Tools.

Wrenches: 19, 18, 17, 13, 10	Le Lock Nut M12 el	Measuring tape	Hammer drill	Concrete drill 14	Lifting crane min. 1 t
					

4. The order of spiral stairs assembly

Assembly instruction shows the ways of spiral stairs individual elements assembly. Before the assembly, it is advised to check delivery content to comply with enclosed delivery specification. In case of any differences, inform the supplier immediately.

4.1. Central pipe foot assembly

Preliminary assembly of central pipe foot starts by putting it in the center of previously prepared concrete foundation in specific distance L from the wall/existing construction. In this step do not fix it to the ground.

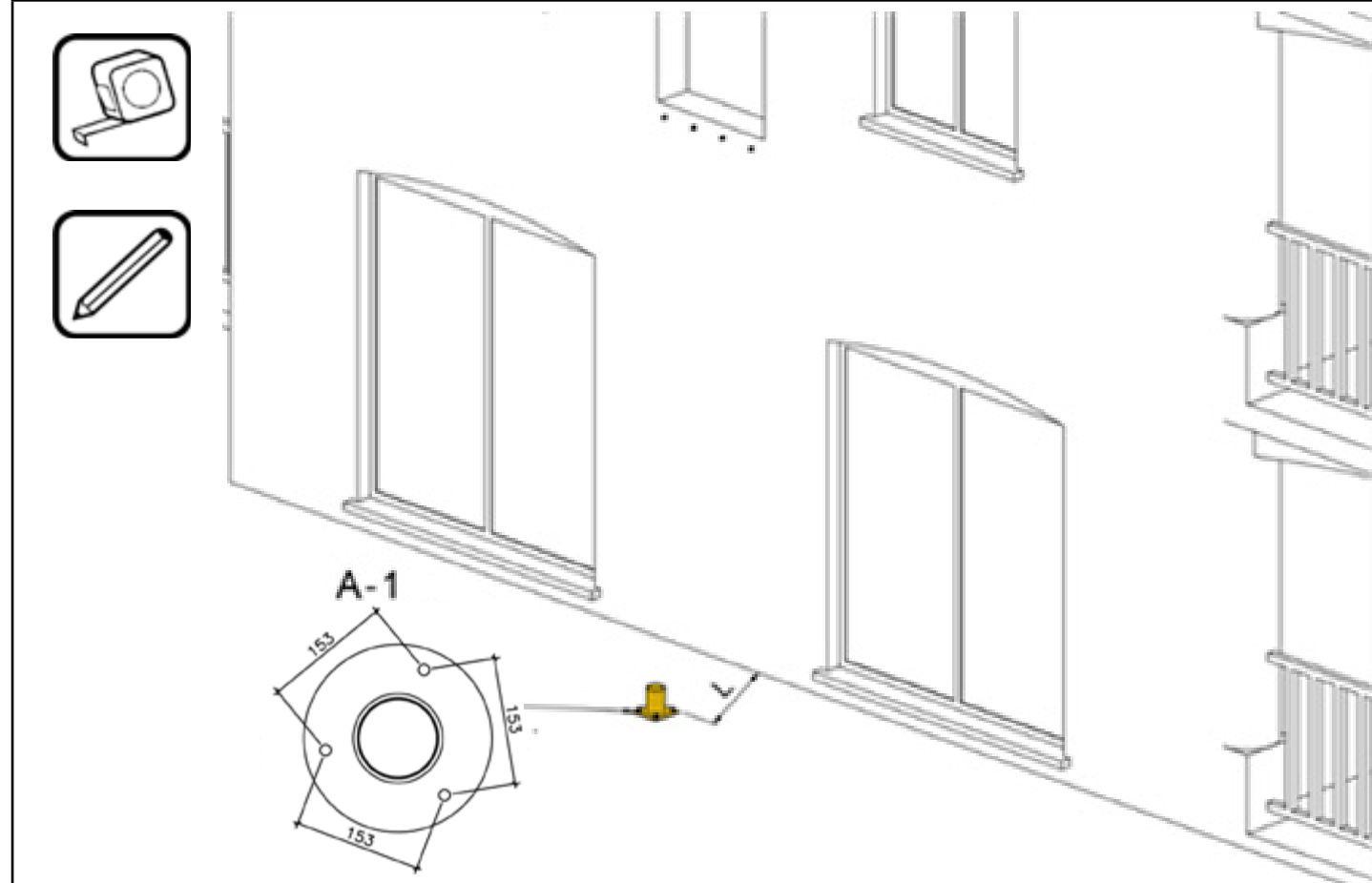

ATTENTION: Anchors and screws for fixing stairs to existing structure are not included in the delivery.

4.2. Proper use of hammer bolts

When assembling components, such as steps or platforms, that are fixed to central columns using hammer bolts, please follow the general instructions below.

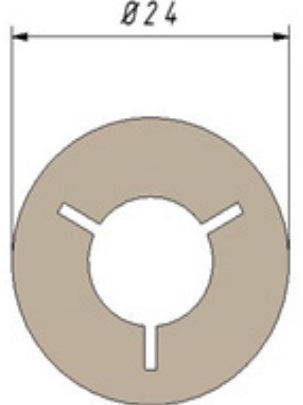
Type of locking washers (O)	Type of locking washers (N)
 <p>Metal – for landings</p>	 <p>Plastic – for steps</p>

First, prepare a set of hammer bolts (C) with plastic locking washers (N). The amount should be equal to the amount of steps:

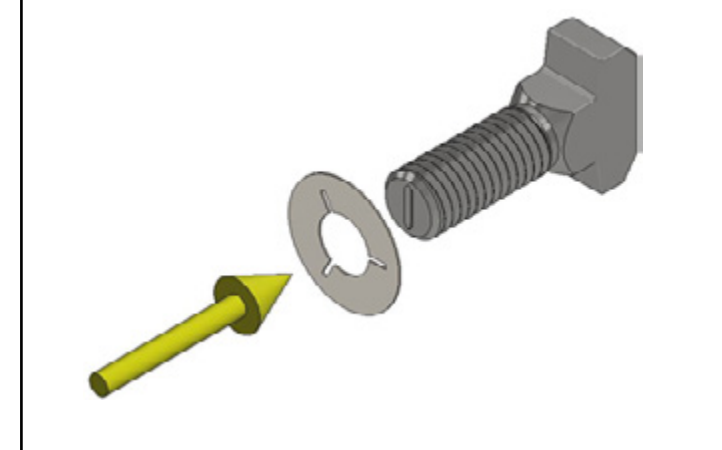

Next, prepare a set of hammer bolts (C) with metal locking washers (O). The amount should be equal to the amount of landing multiplied by 2:

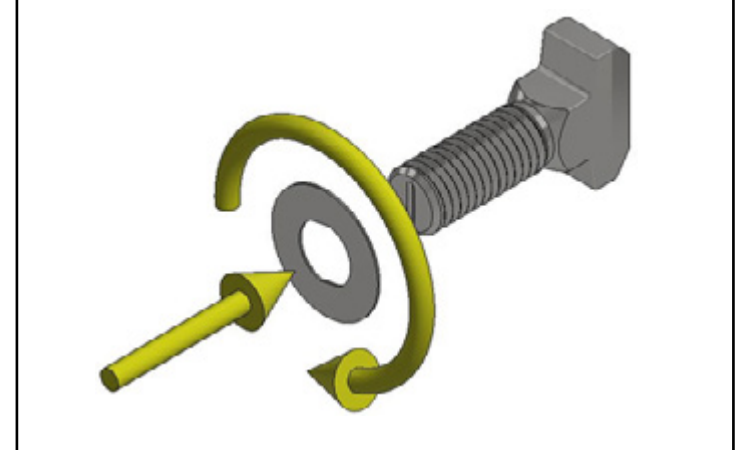

Installation on hammer bolts with locking washer in central column's sockets.

The bolt should be placed in the middle of the hole in the central column, then inserted inwards so that the base of the bolt passes the inner wall of the column.

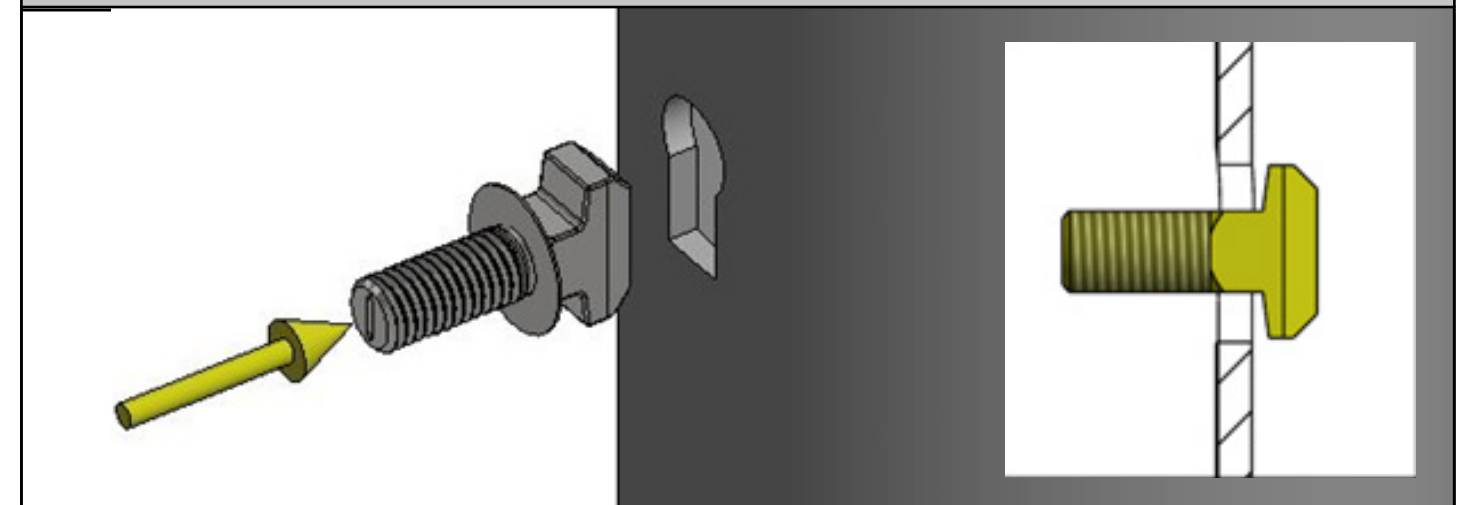

Move the bolt upwards so that its axis is in the center of the circular opening.

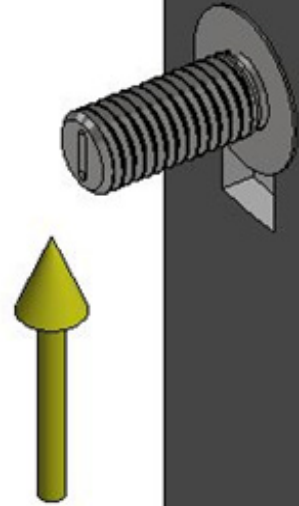

Turn the screw to a horizontal position. Current position of the bolts is shown by the marker at the end of the bolt shaft.

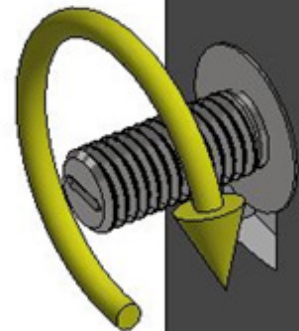

Move the bolt towards the column base to the base of the opening.

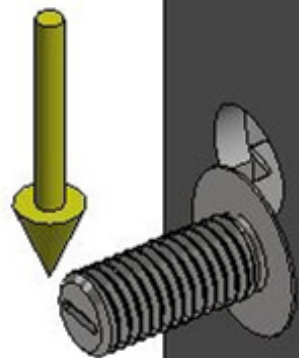

4.3. Platform-to-pipe assembly

Place hammer bolts (C) with locking washers (O) into sockets of central pipe and lock them according to description from point 4.2

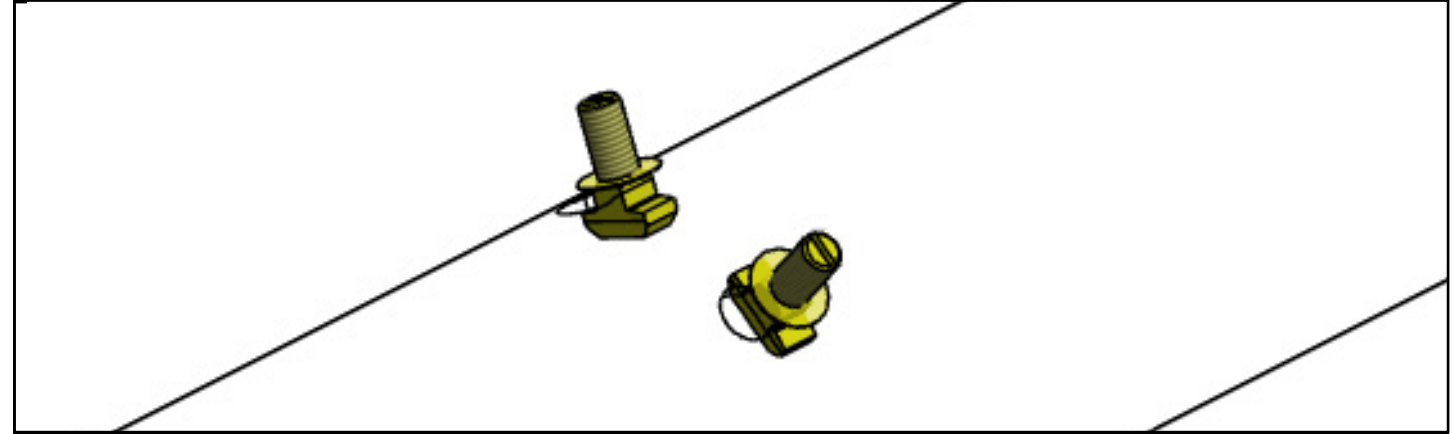

Place the platform on the screws and then tighten connections with the set of:
L - Washer 12; H - M12 self-locking nut.
Tighten the screw connections using approx. 60% of the nominal tightening torque for M12 which is 70 Nm.

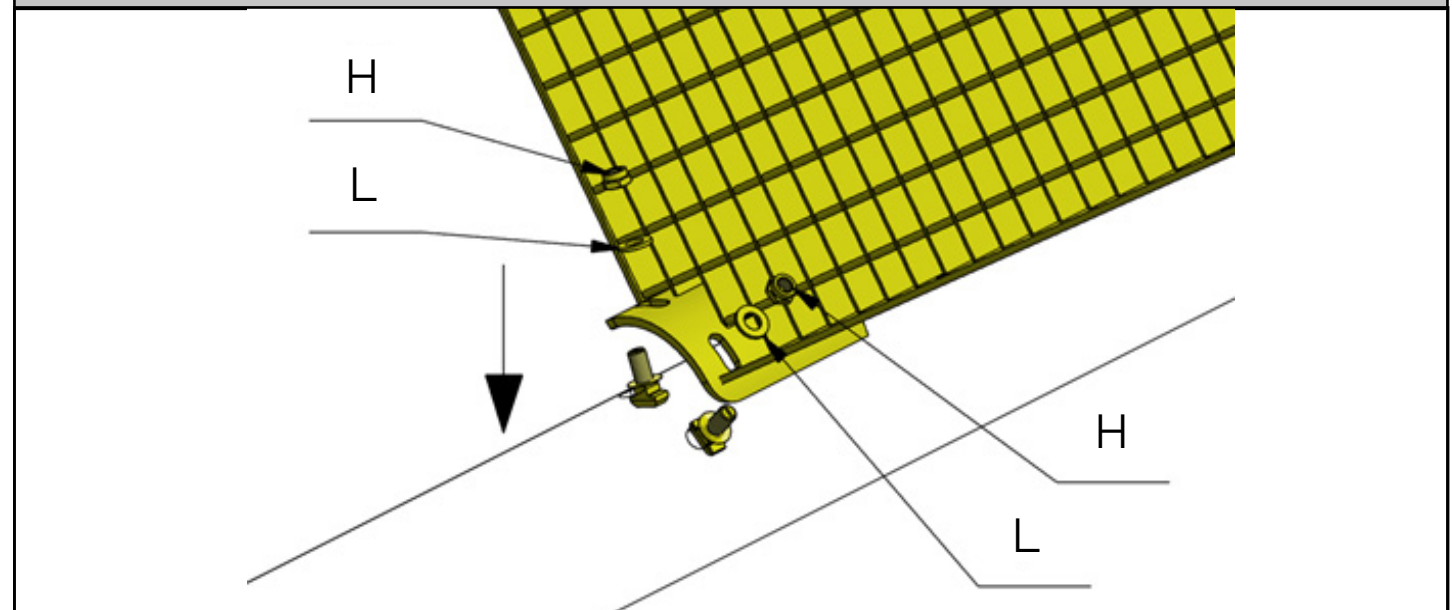

ALTERNATIVE METHOD - WITHOUT USING LOCKING WASHERS
First insert hammer bolts (C) into oval holes of platform's fastening plate. Put M12 washers (L) and screw self-locking M12 nut (H) using fingers until it's possible (till the moment when the end of bolt's thread reaches nylon insert in the nut).
Set hammer bolts vertically - the position of the bolts is shown by the marker at the end of the bolt shaft.
Move the platform with the bolts towards central pipe so that screw heads go into the slots in central pipe.

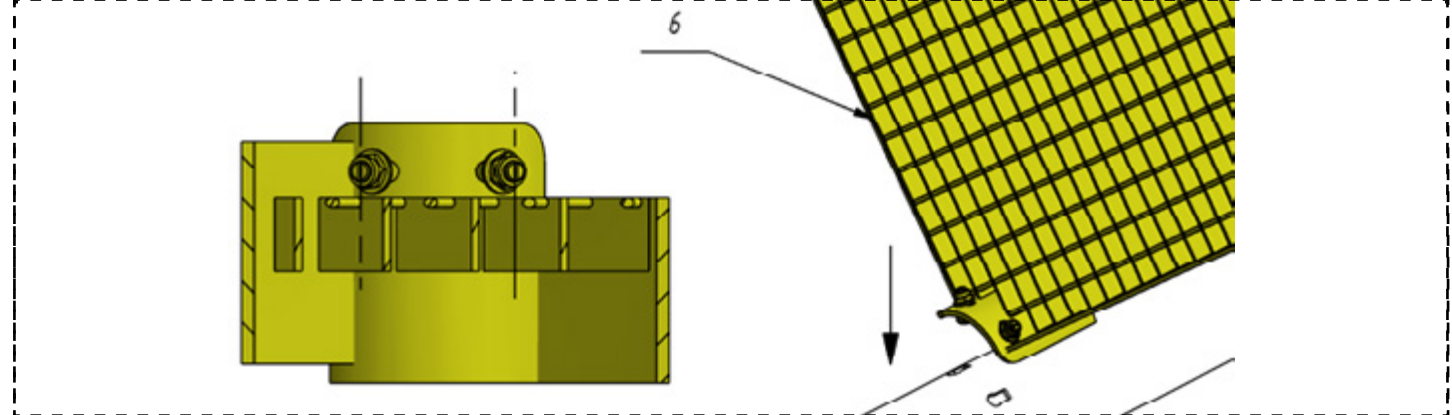

After inserting the platform together with the set of bolts to the sockets, turn the hammer bolts to the horizontal position and then move the whole unit towards the column base until it stops. Align the screws in the center of oval holes in landing's fastening plate. Tighten the screw connections using approx. 60% of the nominal tightening torque for M12 which is 70 Nm.

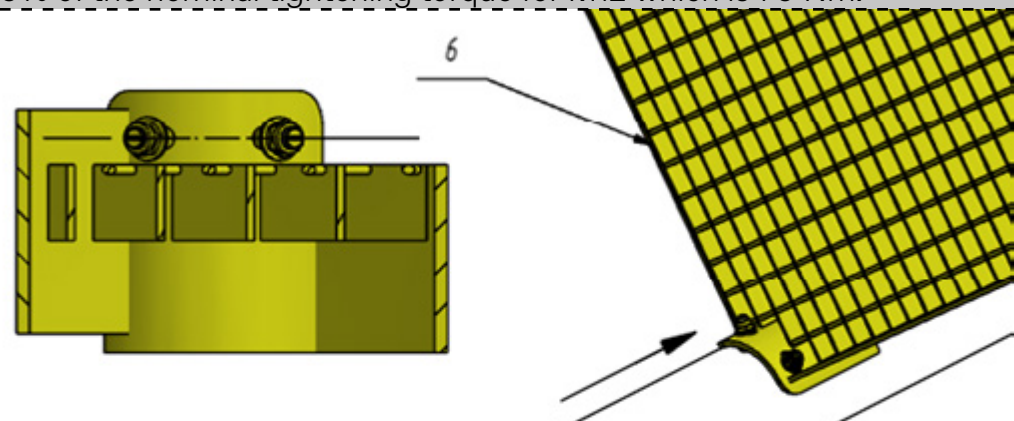

4.4. Central pipe assembly

Lift central pipe together with landing. Place central pipe on foot.

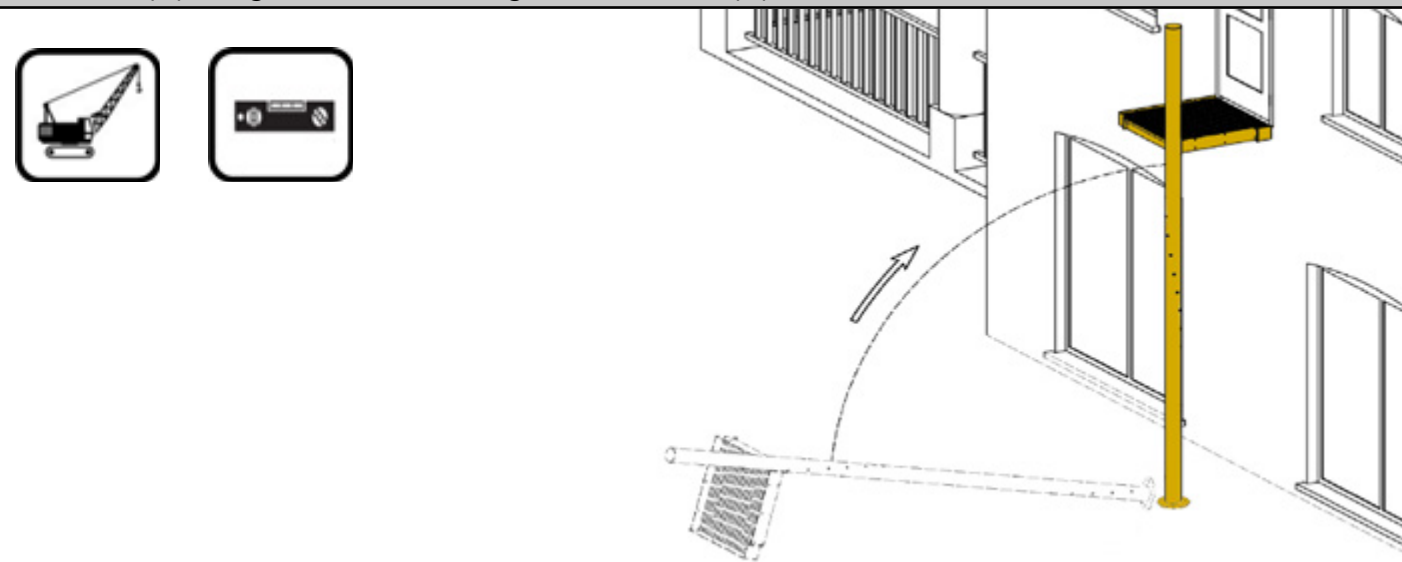

After aligning and leveling of landing, drill $\varnothing 14$ holes and place anchors inside them. B – Threaded rod M12x200; L – Washer 12; G – Nut M12; P – Chemical anchor.

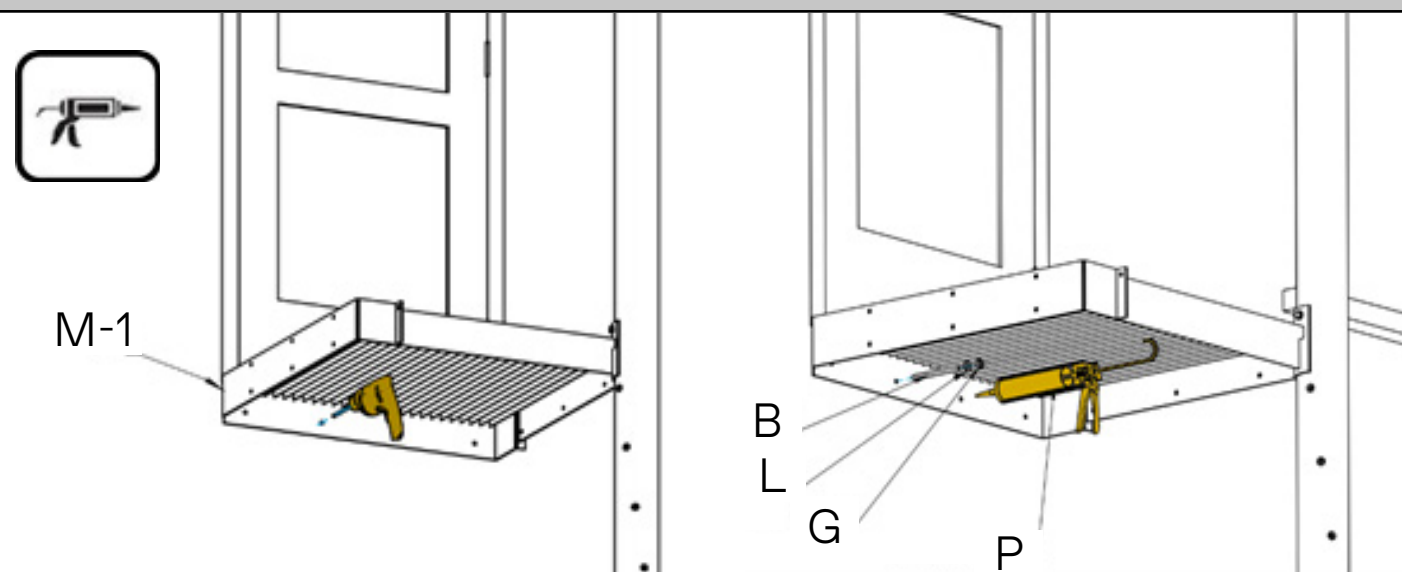

Fix the landing to existing construction.

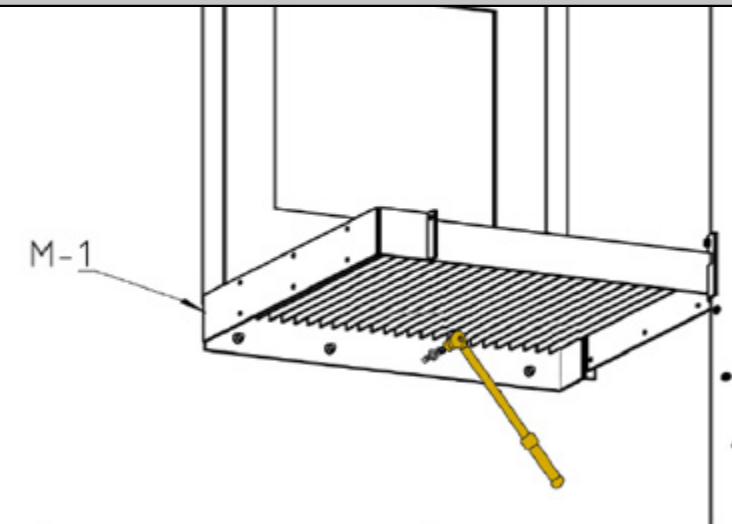

Check the upright position of central pipe and fix foot to the ground using chemical anchors. P – Chemical anchors; G – Nut M12; L – Washer 12, B – Threaded rod M12

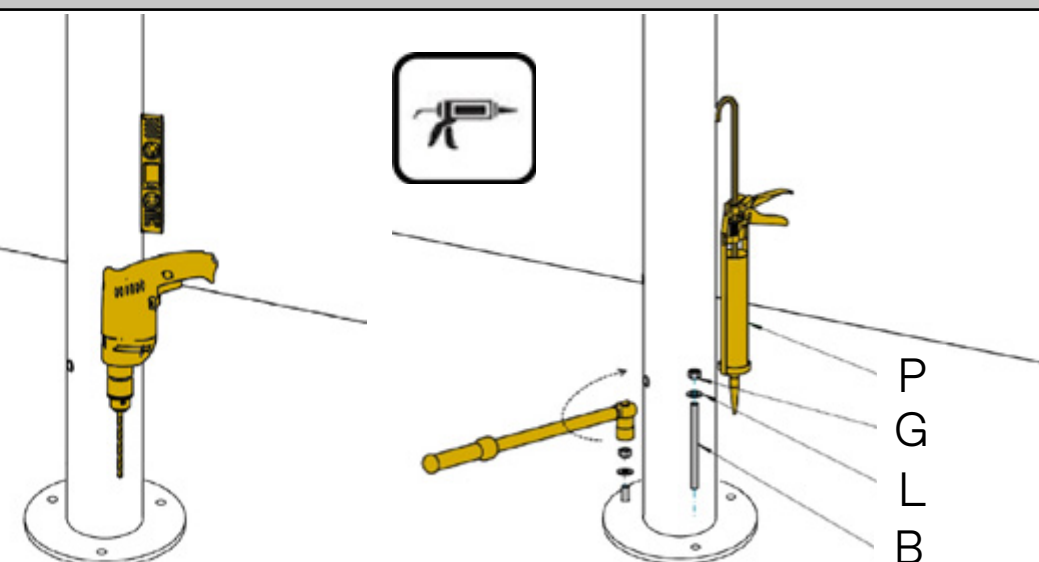

4.5. Steps assembly

Place hammer bolts (C) with locking washers (N) into sockets of central pipe and lock them according to description from point 4.2. Repeat procedure for each step in stair flight.



Place the step on the screw and then tighten it with the set: L - Washer 12; G - M12 self-locking nut. Tighten the screw connections using approx. 60% of the nominal tightening torque for M12 which is 70 Nm.

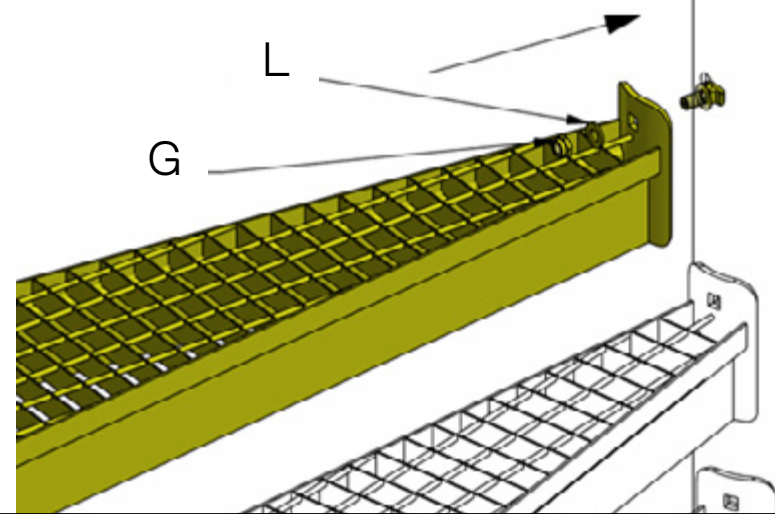

ALTERNATIVE METHOD – WITHOUT USING LOCKING WASHERS

First insert hammer bolts (C) into square holes of step's fastening plate. Put M12 washers (L) and screw self-locking M12 nut (G) using fingers until it's possible (till the moment when end of bolt's thread reaches nylon insert in the nut).

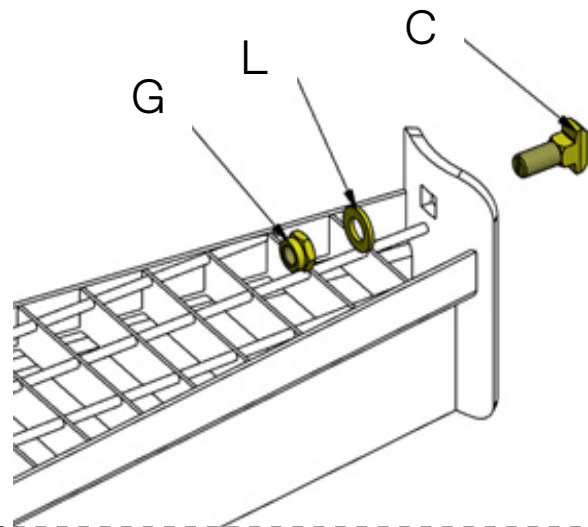

Set hammer bolts vertically - the position of the bolts is shown by the marker at the end of the bolt shaft. Attach steps by inserting the hammer bolts to the sockets in the central pipe.

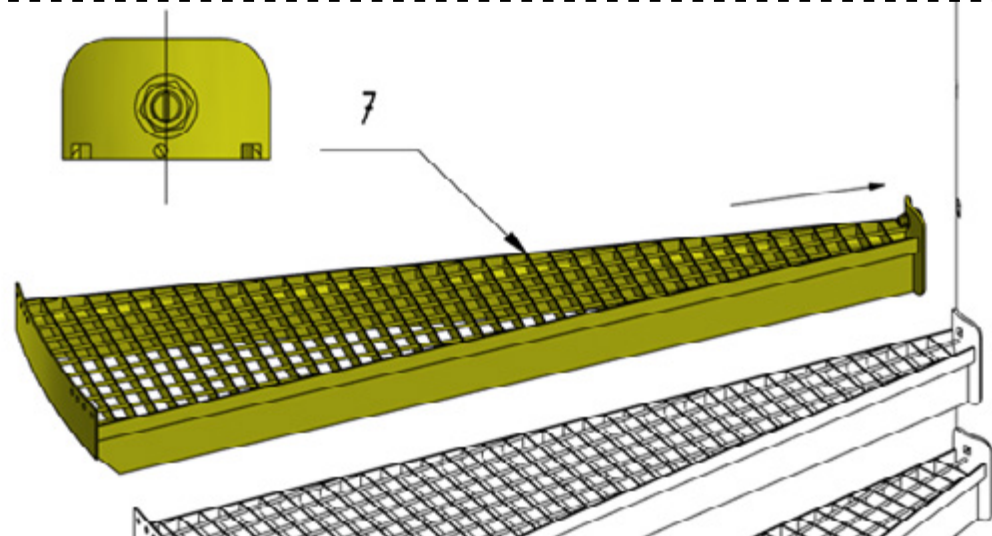

After inserting the hammer bolt into the sockets, turn the hammer bolts to the horizontal position and then move the whole unit towards the column base until it stops. Tighten the screw connection using approx. 60% of the nominal tightening torque for M12 which is 70 Nm. Repeat procedure for every step in stairflight.

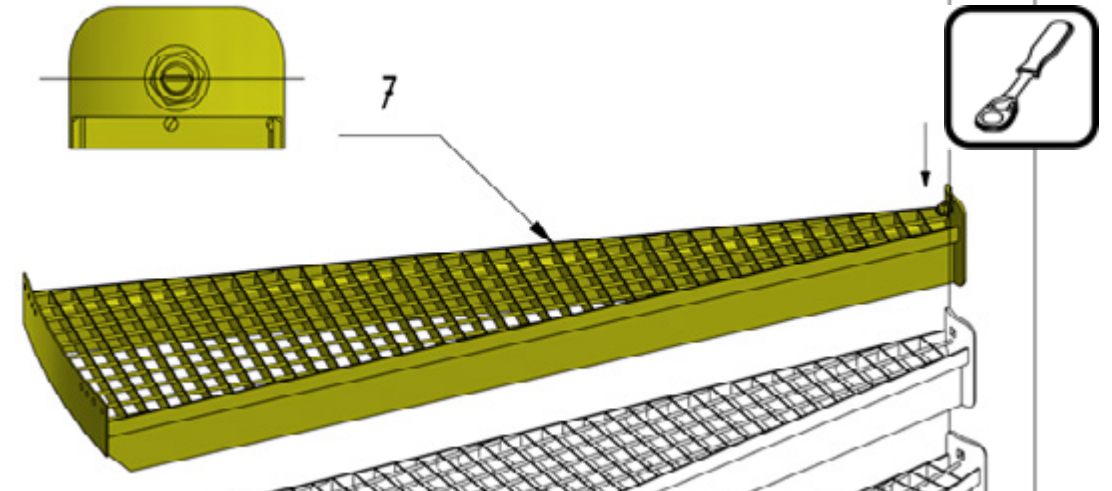

4.6. Railings assembly

Rail posts assembly should be started from hole no. 1 (outward hole in first step). Rail post no. 1 is fixed to the ground using foot M-D-A-6.

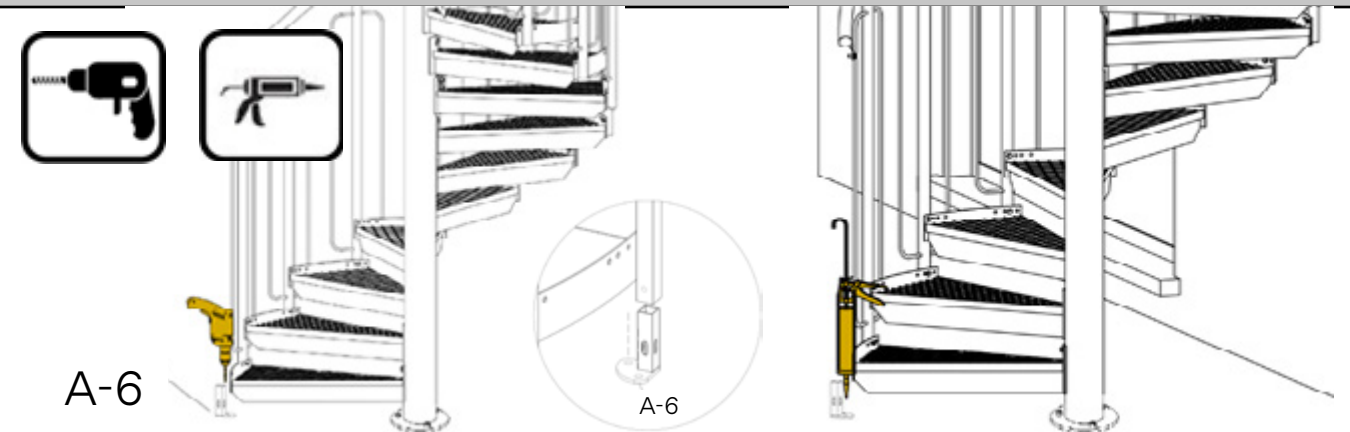

Rail posts have got assembly holes, through which they are fixed to steps according to the assembly drawings. Based on this drawings place D screw through the hole at the back of the step. Fix railpost through the bottom hole. Then repeat above operation using the first hole of front side of following step and the middle hole in rail post.

Remember not to tighten the connection too much - use about 60% of needed tightening torque - about 6 [Nm] D – Screw M8×25; J – Washer M8;

Note, that steps have symmetrical holes in the side plate – the same steps can be used for left of right direction of stairs.

Rail-posts connect two steps together by holes in side plate. Every rail-post have 3 threaded holes – the two of them (first and middle), which are closer to each other, correspond with the steps/landing, while the third one is used to fix handrail. General rule of installing rail-posts on stair's flight is, that middle hole always corresponds with first hole on next step (marked 'M' on drawing below).

First hole of rail-post corresponds with certain hole on current step. Knowing stair radius and number of steps/revolution, it could be easily determined, which hole to use, by looking on the table below.

ATTENTION: Carefully read drawings supplied with stairs to understand how many steps per revolution stairs have. This drawing shows also which hole on current step should be used for connecting rail-post through first (bottom) rail-post hole.

ATTENTION: Sometimes stairs have different steps/revolution factors on different levels

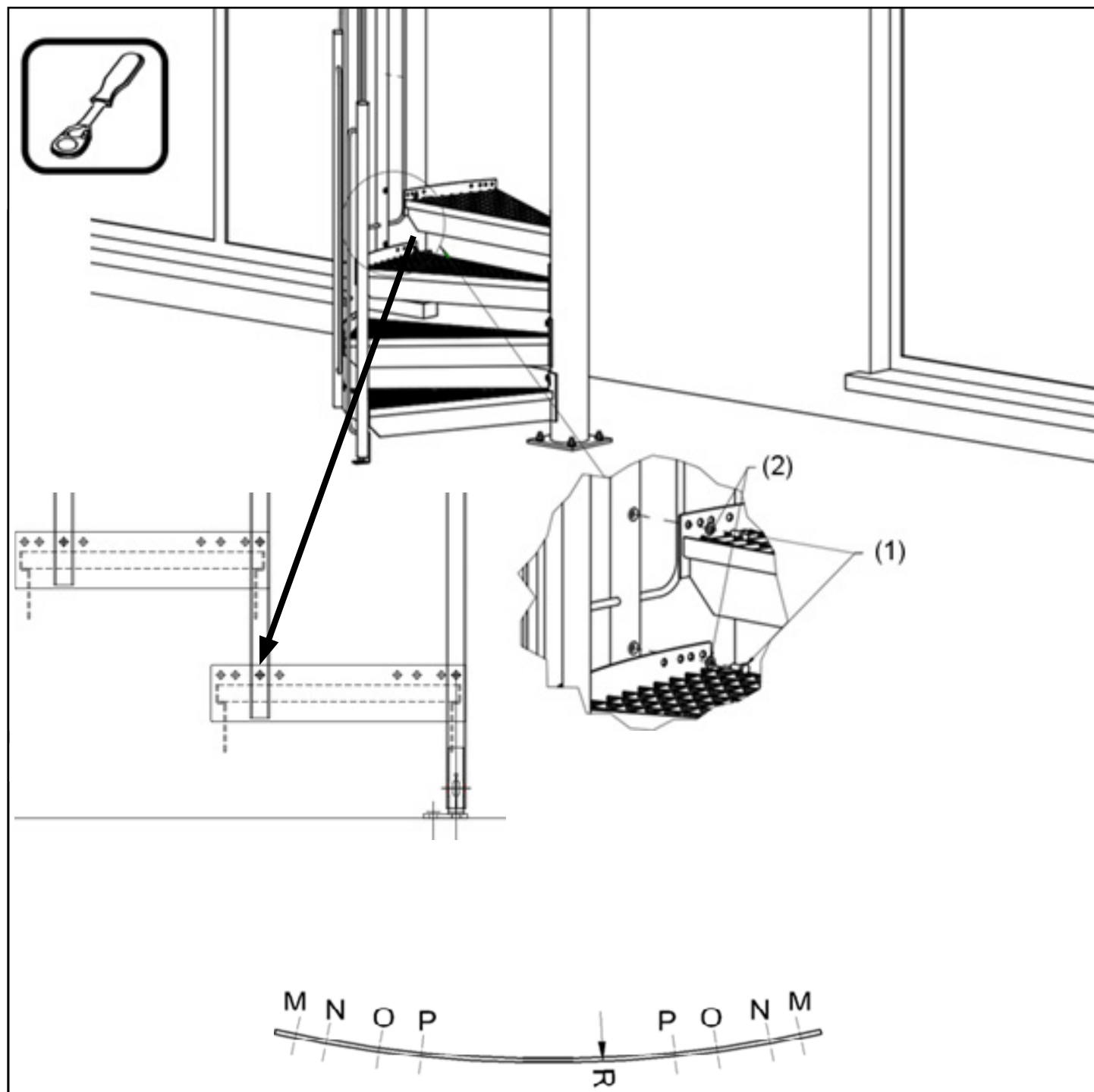

STAIR RADIUS	STAIR RADIUS																				
	550	600	650	700	750	800	850	900	950	1000	1050	1100	1150	1200	1250	1300	1350	1400	1450	1500	
STEPS / REVOLUTION	M	14	14	14	14	14	14	15	15	16	16	16	18	18	18	18	18	20	20	22	24
	N	15	15	15	15	15	15	16	16	18	18	18	20	20	20	20	20	22	22	24	26
	O	16	16	16	16	16	16	18	18	20	20	20	22	22	22	22	22	24	24	26	28
	P	18	18	18	18	18	18	20	20	22	22	22	24	24	24	24	24	26	26	28	30

Assemble handgrip from the beginning of the stairs flight (from step 1), successively tightening particular parts up the stairs flight. (no 2, 3).
 D – Screw M8×25, J – Washer M8, I – self-drilling screw 4,2×16

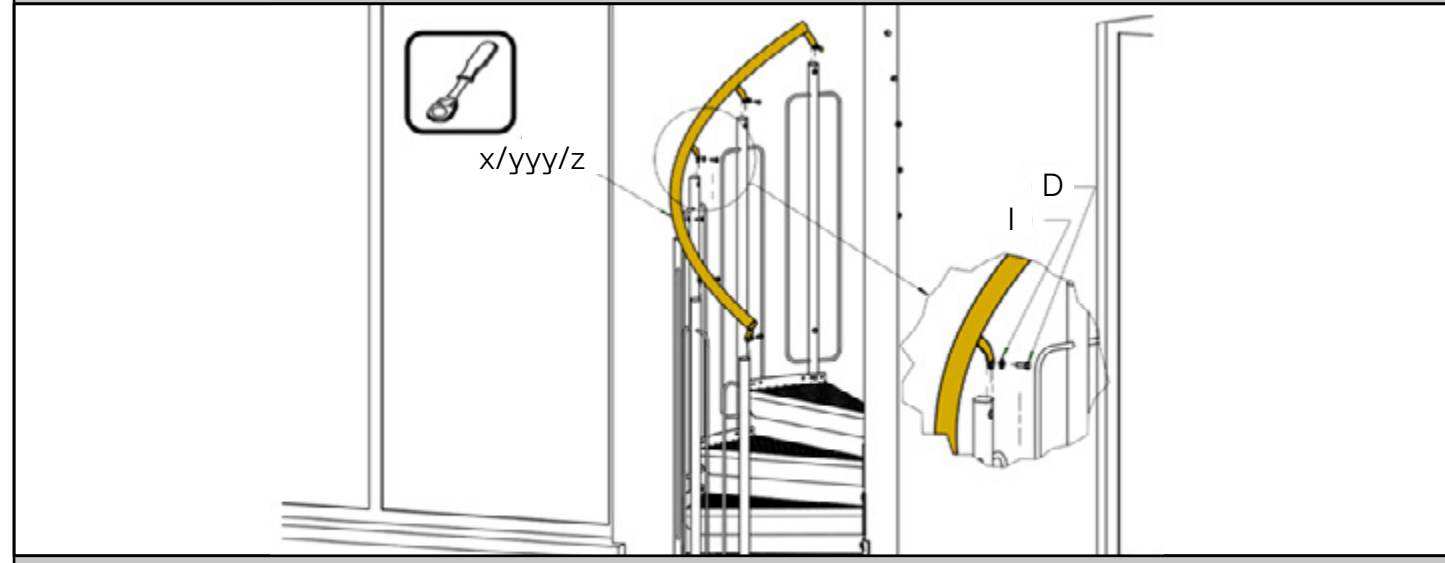

Continue adding next handrail parts (marked x/yyy/z/H-2... x/yyy/z/H-n) until all are in place. Use M8×25 screws (D) + M8 washers (J) to fix handrail parts to rail-posts.

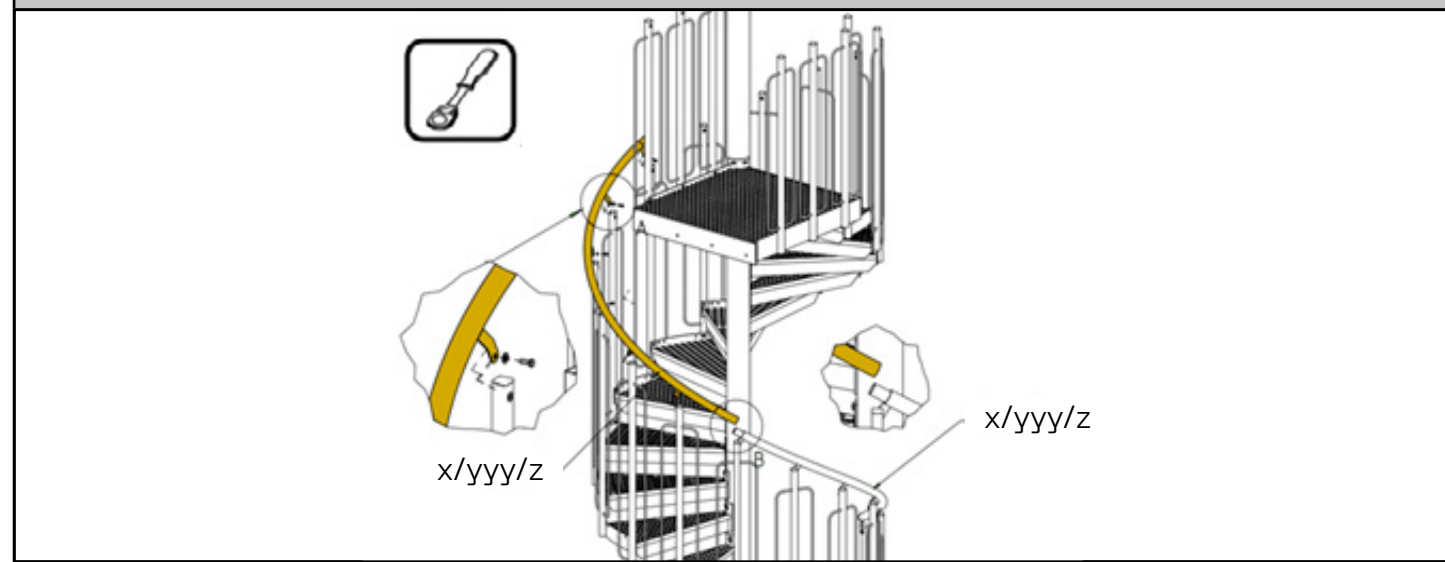

Next, handgrip elements should be fixed together using self-drilling screws.
 D – Screw M8×25, J – Washer M8, I – self-drilling screw 4,2×16

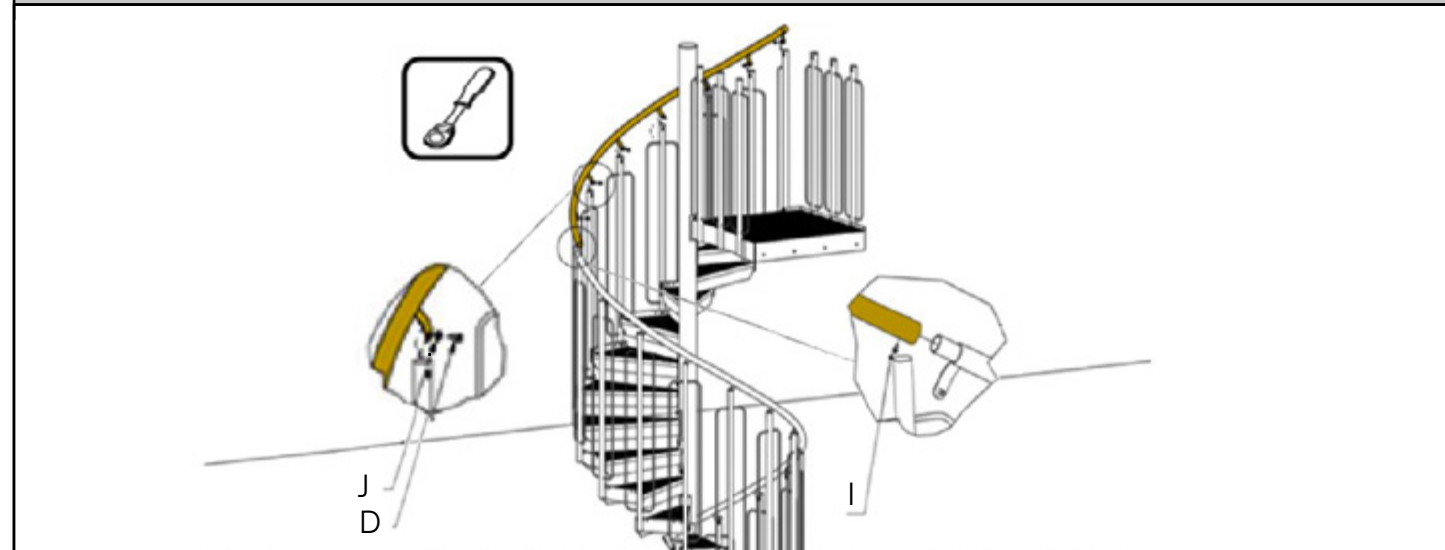

Proceed in the same way with platform handgrips.



x/yyyy/z/HL-n

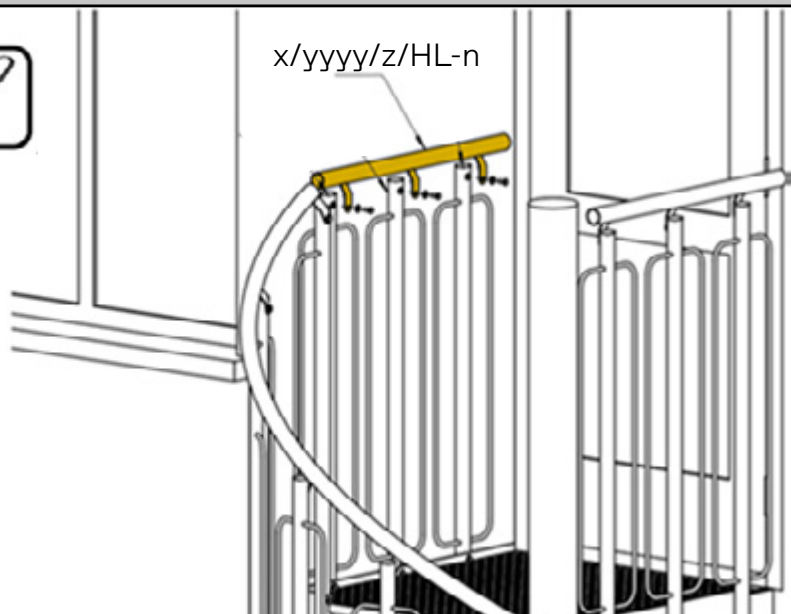

Starting from last step, check with level if rail posts align vertically and after correction (if needed) fix first rail post to the ground using foot A-6.

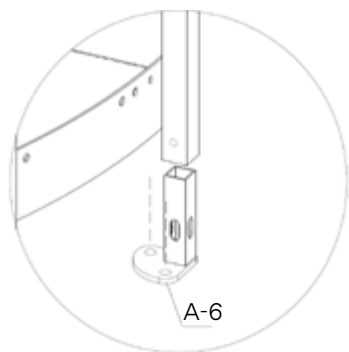
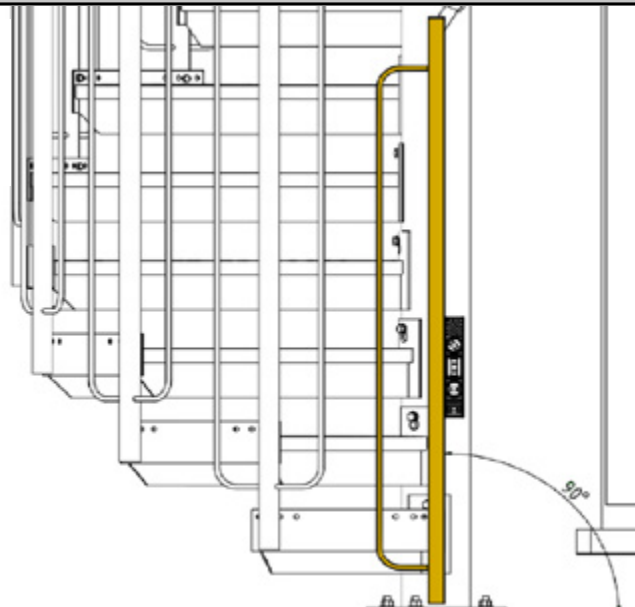

A-6

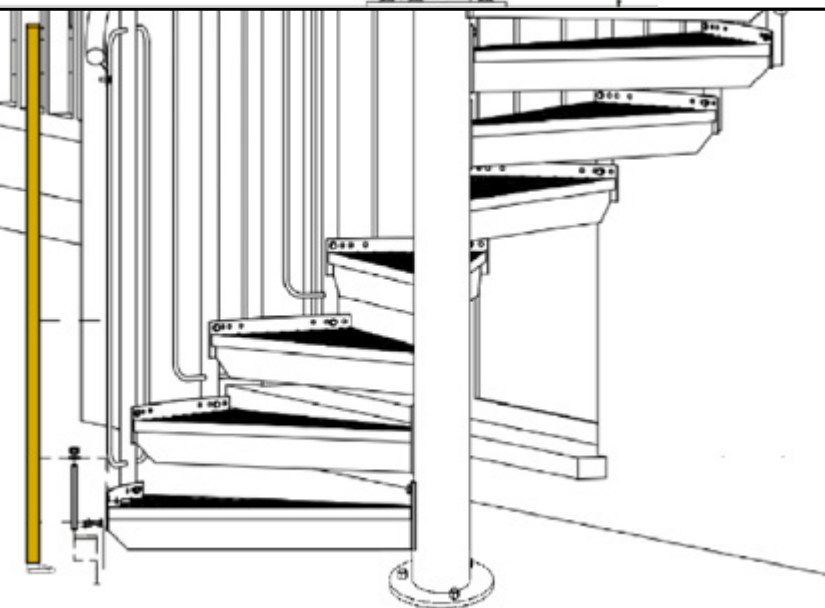

In the case of stairs with a radius greater than 1250 mm, the post no. 2 (R-2A) is fixed with an additional plate to fix to next step (using M8×25 bolt (D), 2 washers 8 (J) and a M8 nut (E) and to the ground with the foot M-D-A-6.



R-2A

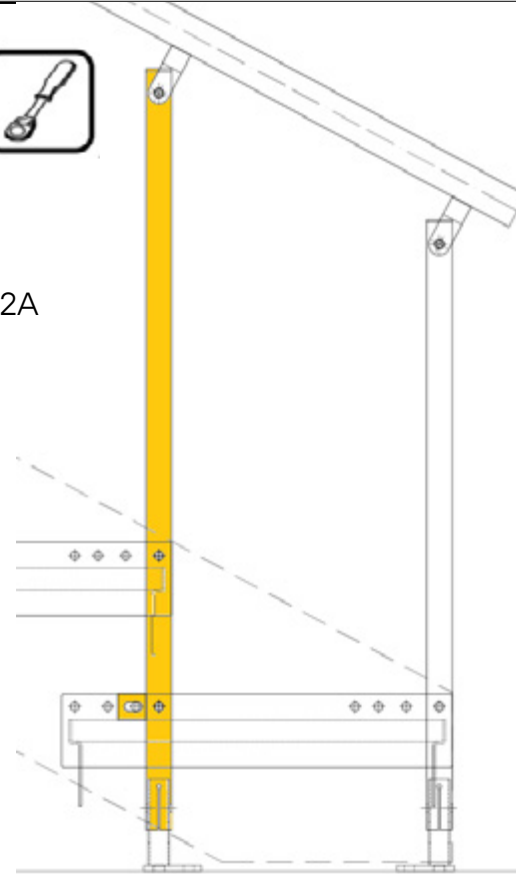

M-D-A-6

M-D-A-6

Other rail posts on spiral part of staircase (R-nA) are also equipped with additional plate to be fixed to next step using M8×25 bolt (D), 2 pcs. washers 8 (J) and a M8 nut (E).

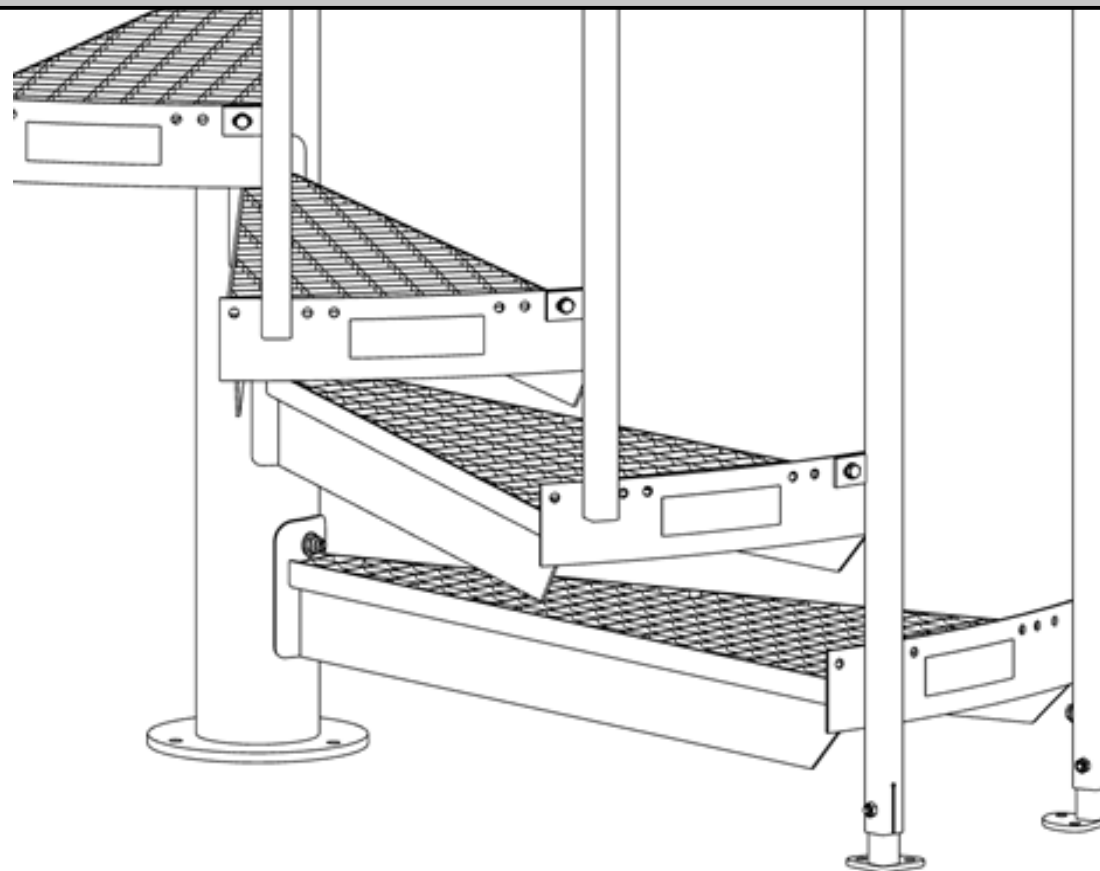

Alternatively to solution presented above, for radius greater than 1250 mm outer kickplate (stringer) can be used. Kickplate should be assembled between steps and railposts using bolts intended to fix railposts to steps: D – Screw M8×25; J – Washer M8;

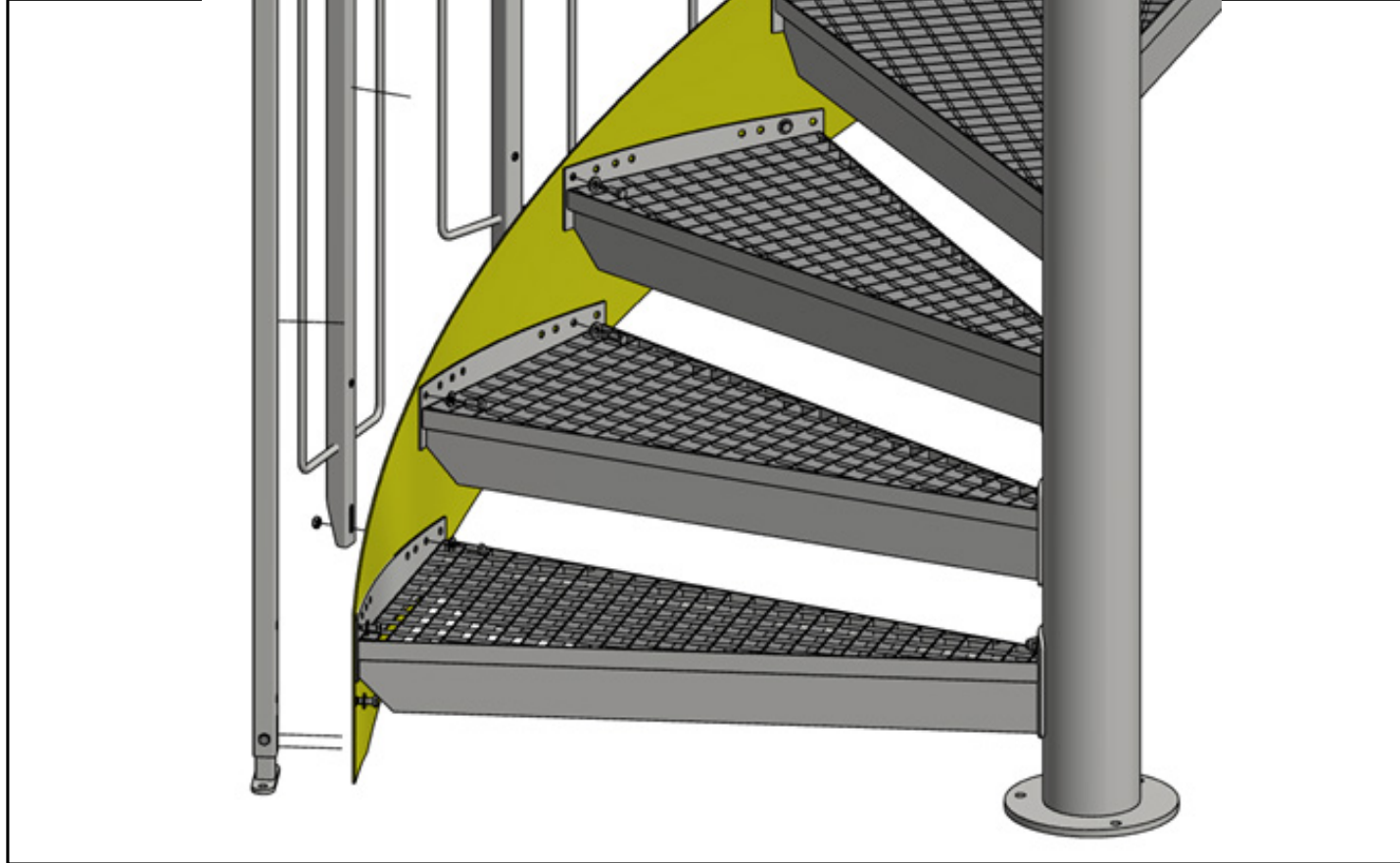

Kickplates should be connected using prepared brackets and fastenings: D – screw M8×25, E – Nut M8, J – Washer M8;

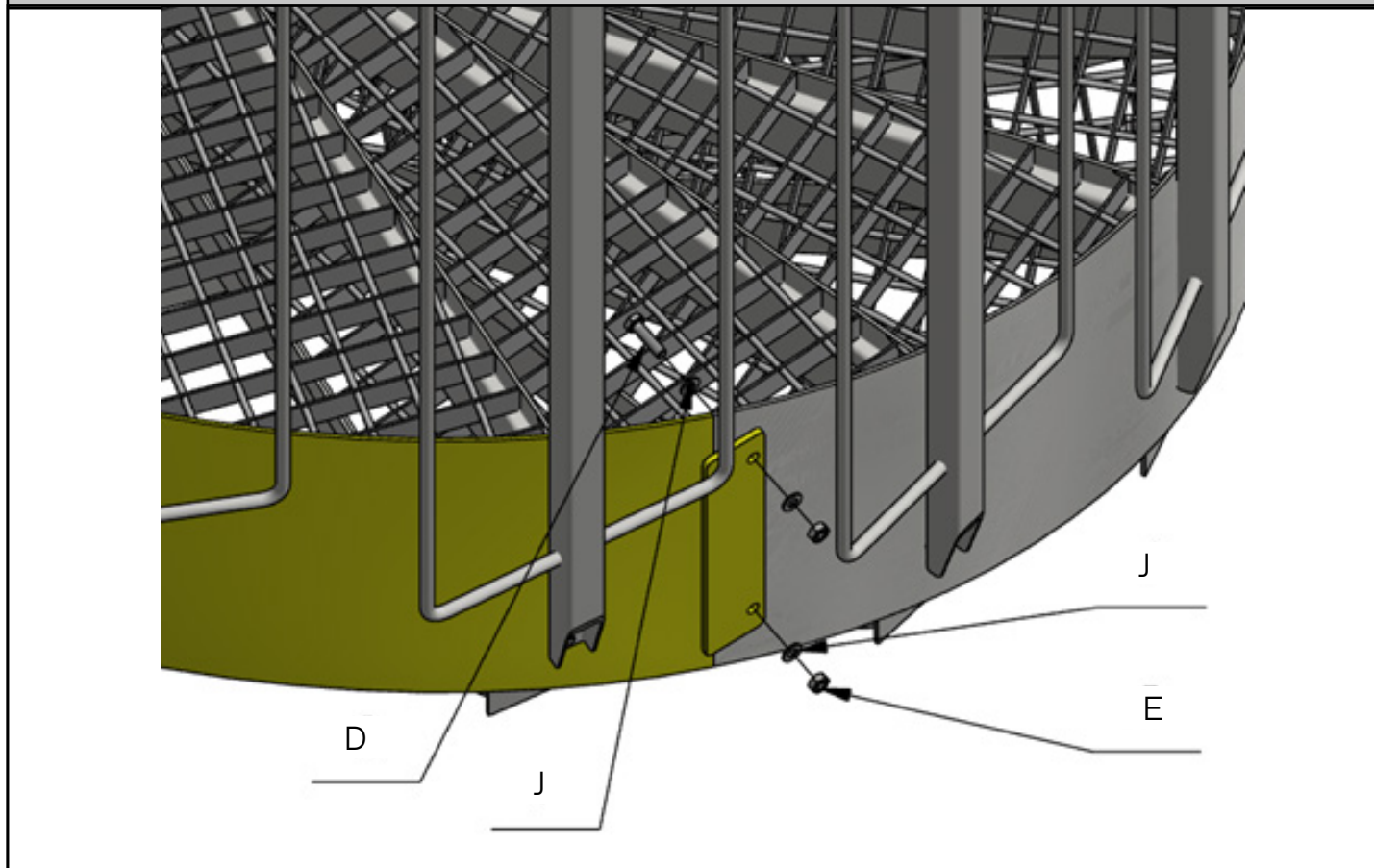

Check presence of plastic caps at the top of the central pipe (T), rail posts (S) and handrails (R) and press them on their place if needed.

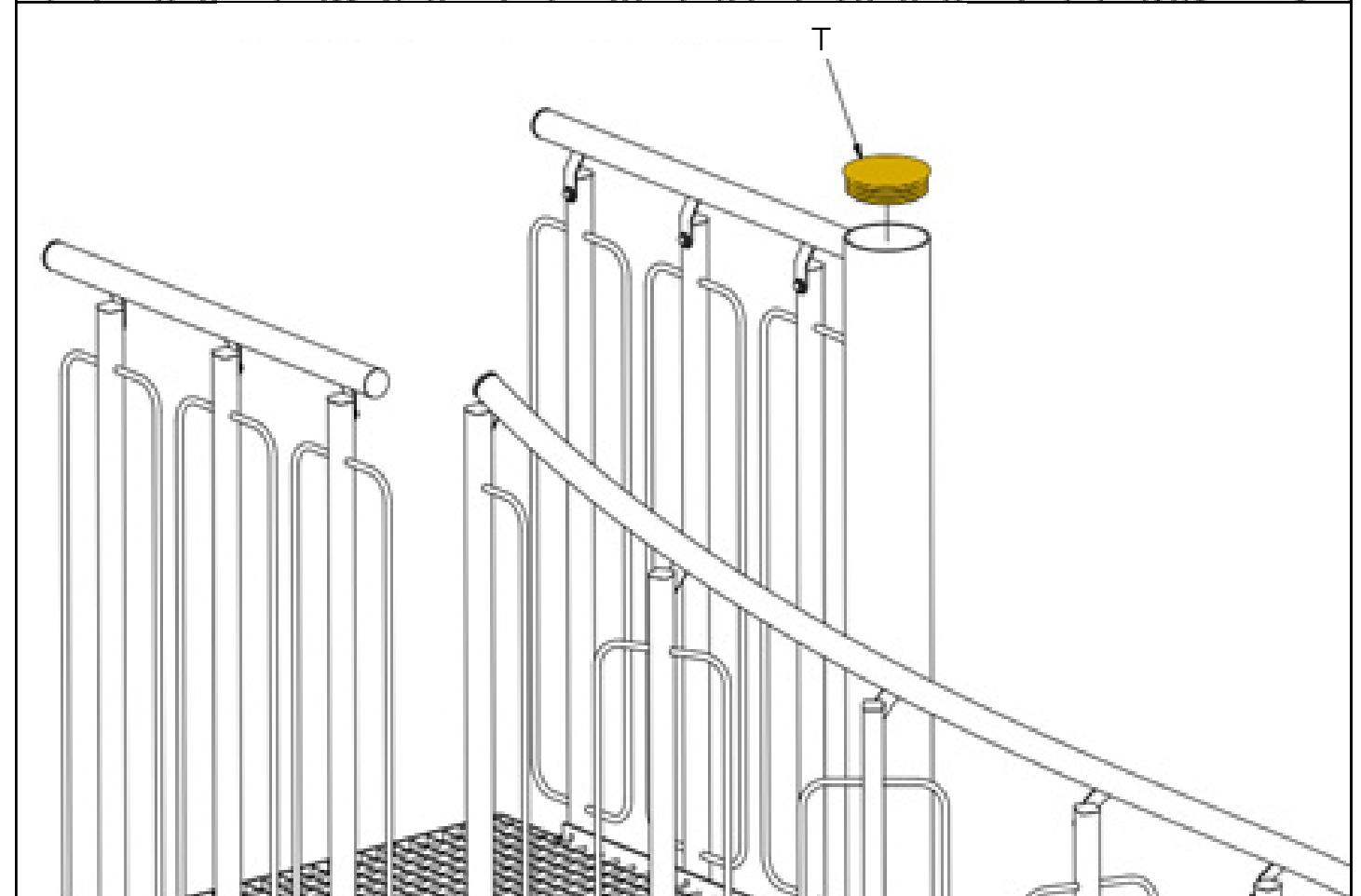
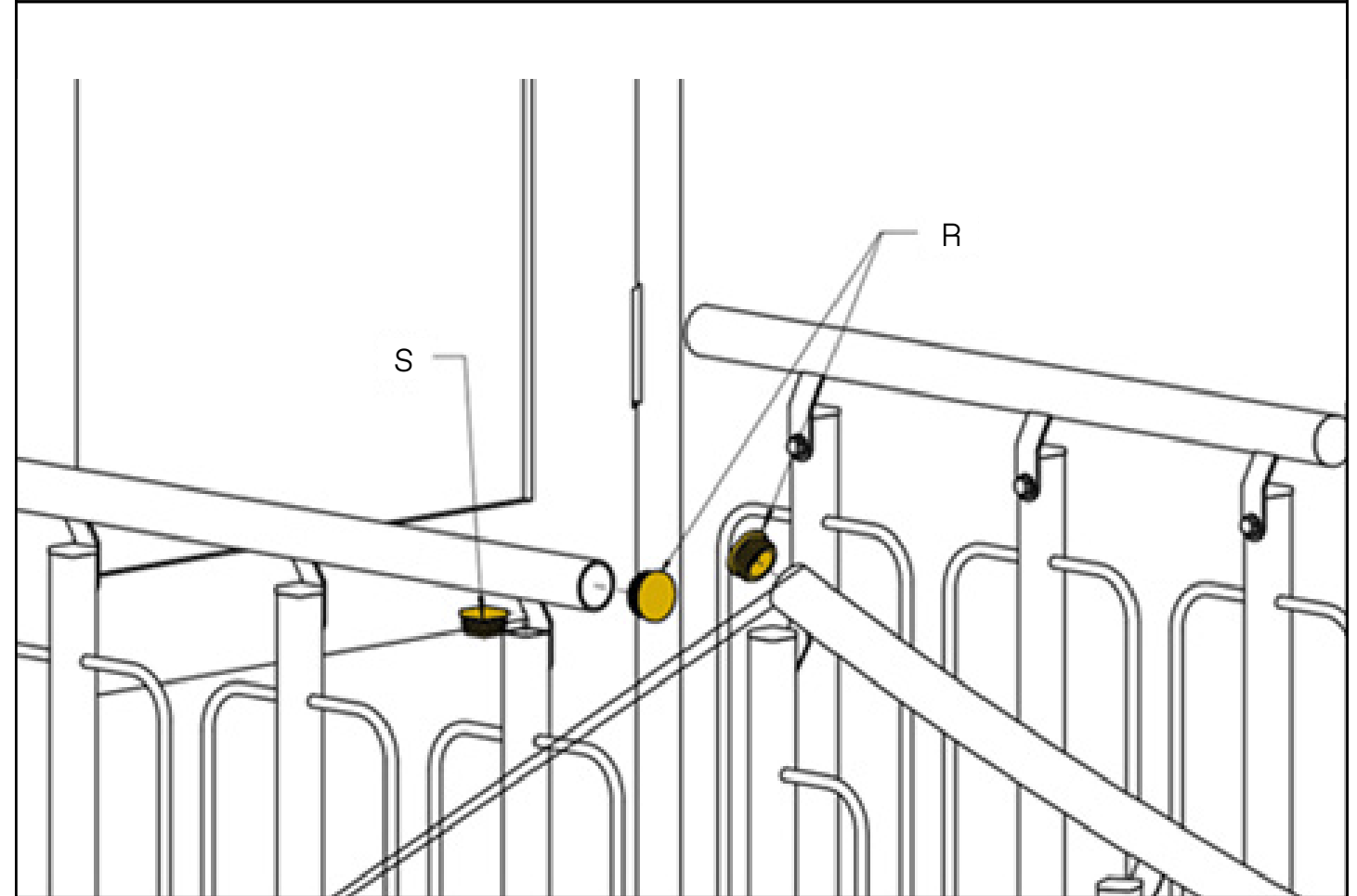

4.7. Multilevel stairs*

In case of multilevel stairs, repeat the action from 4.2 point.

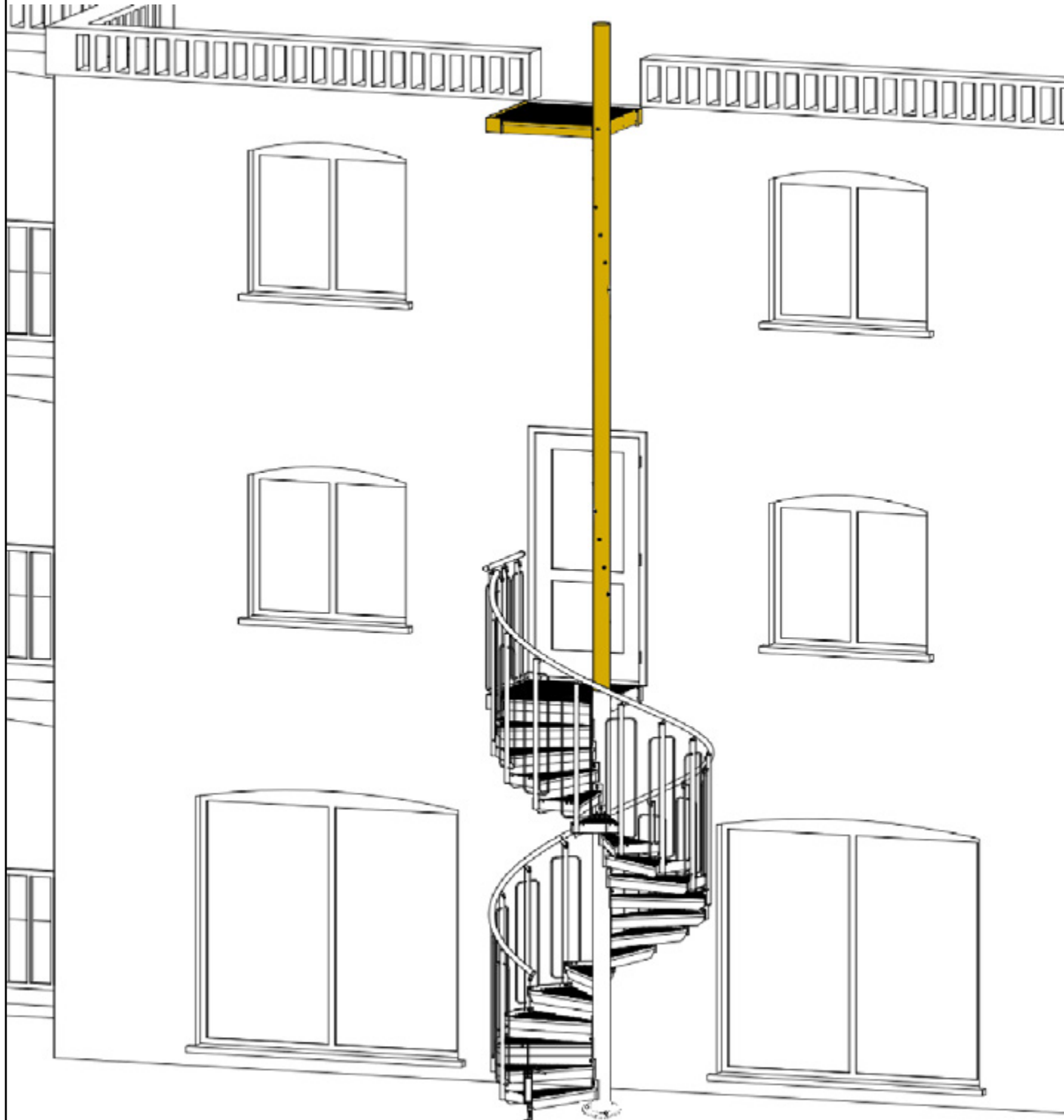

4.8. Spiral stairs grating cage assembly**

Grating cage assembly starts with fixing hinges and the door. Screw the lower hinges parts (Z-3) to the holes in central pipe. Next, place the door leaf on them.

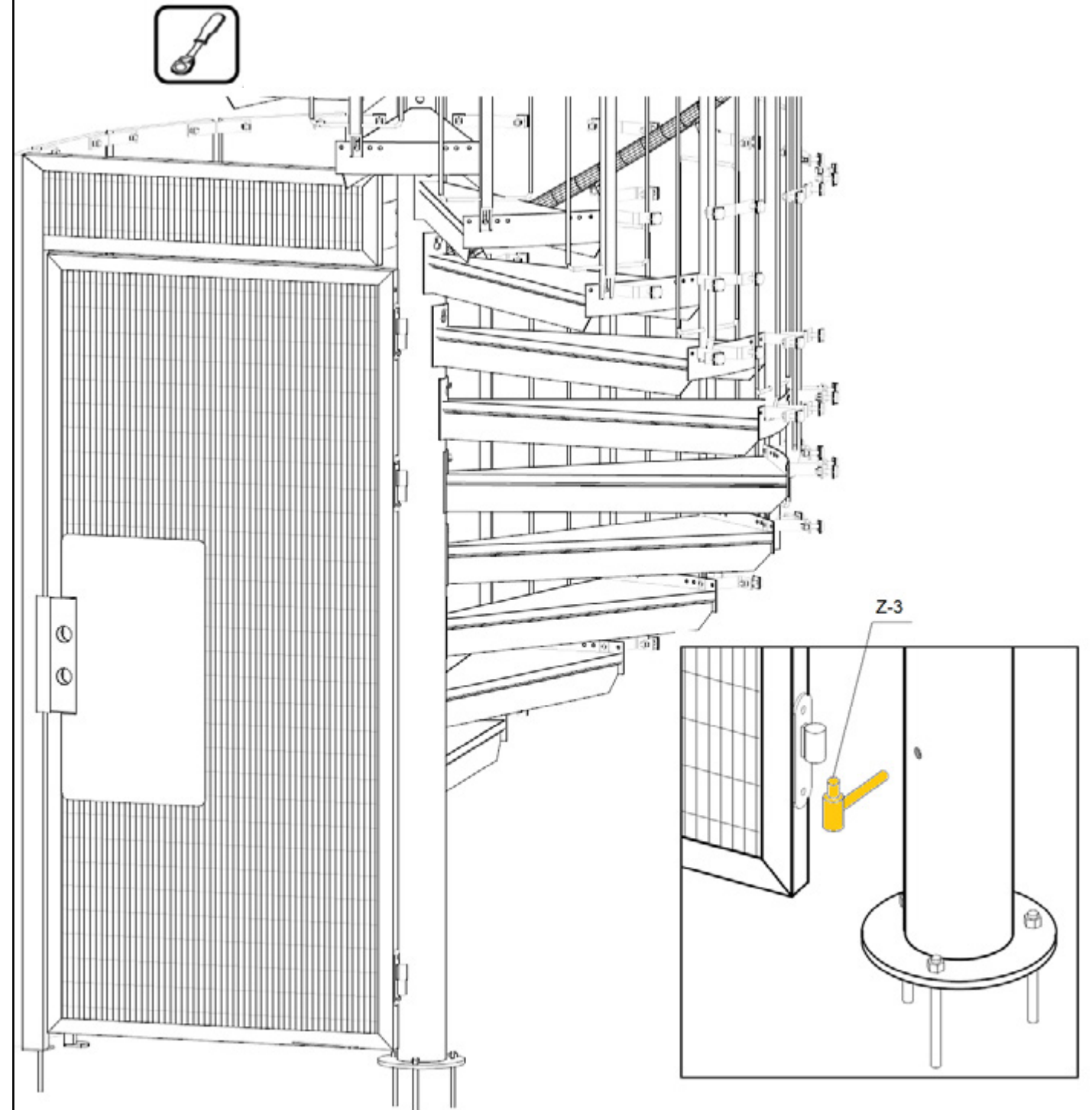

Fix the A-7 door frame bracket to the central pipe, then fix the door frame D-2 to bracket A-7.
 U – Screw M10×40 8.8

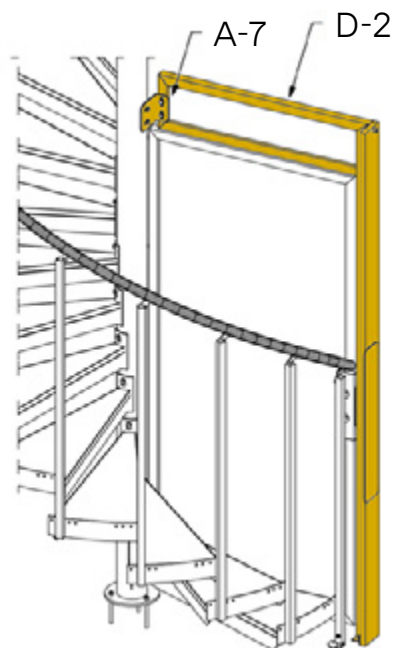

Check upright positions of the door frame D-2 and after correction, if necessary, anchor it (using M12 anchors) to the ground.
 (O – chemical anchor, B – threaded rod M12, L – washer M12, G – nut M12)

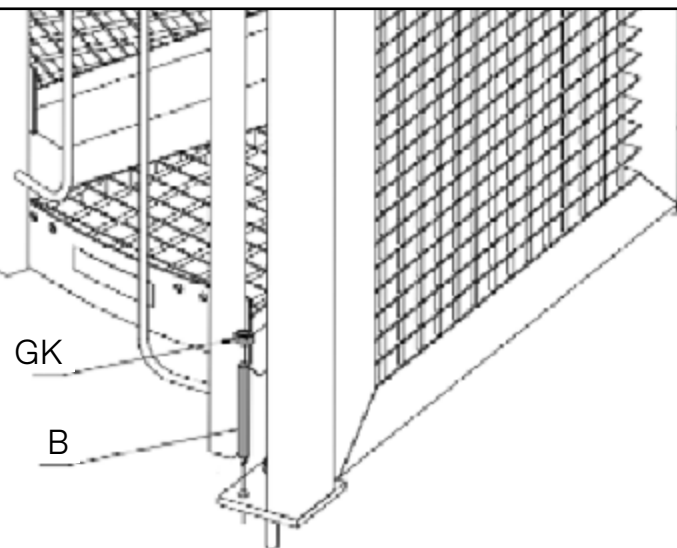
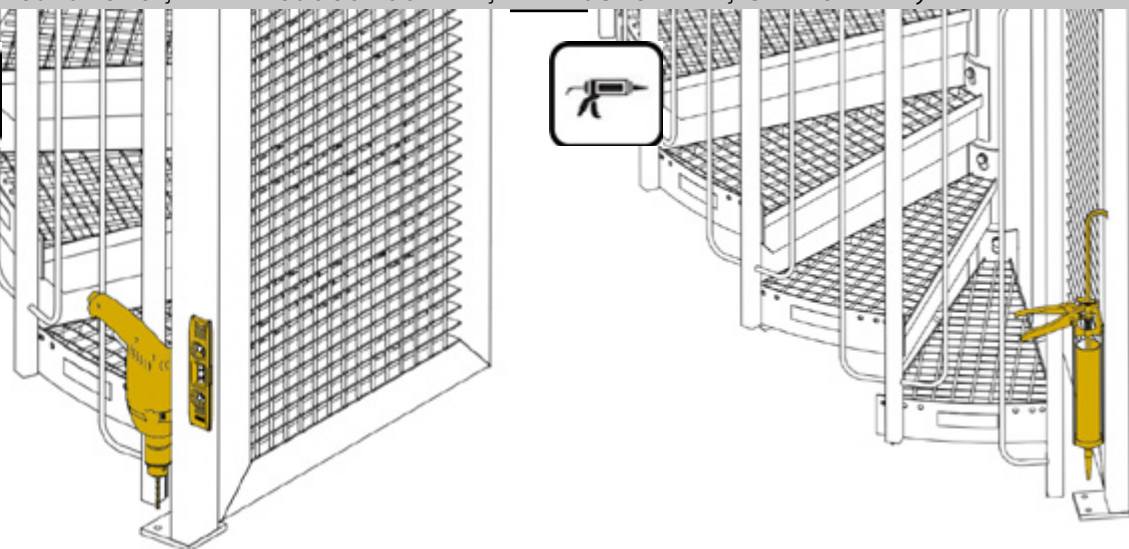

4.9. Grating cage assembly

Fix brackets L-1, L-2, L-3 to rail posts according to the assembly drawing.
 D – Screw M8×25, J – Washer M8

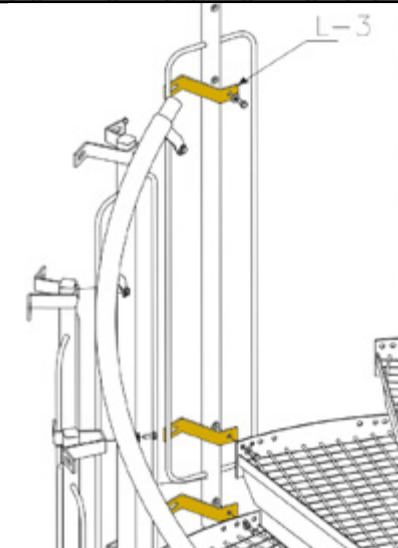
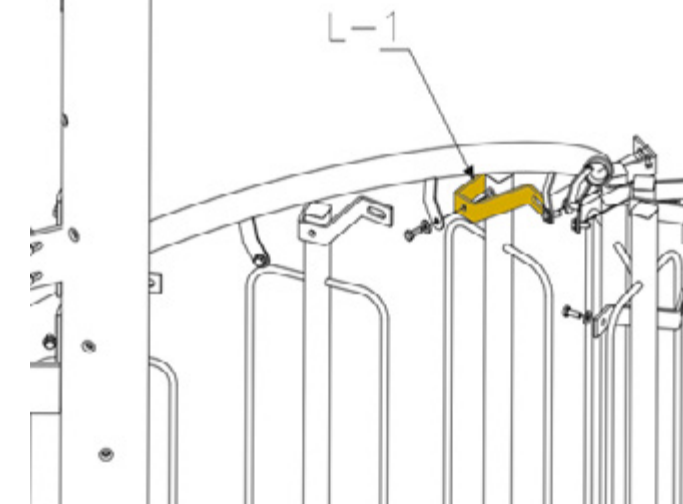

Assembly of cage panels starting with grating P-1 to the last grating according to the assembly drawing. Use top parts of grating fixings (L).
 A – Bolt M10×50; M – grating fixing (top part) G-11; K – Washer 10; F – Nut M10

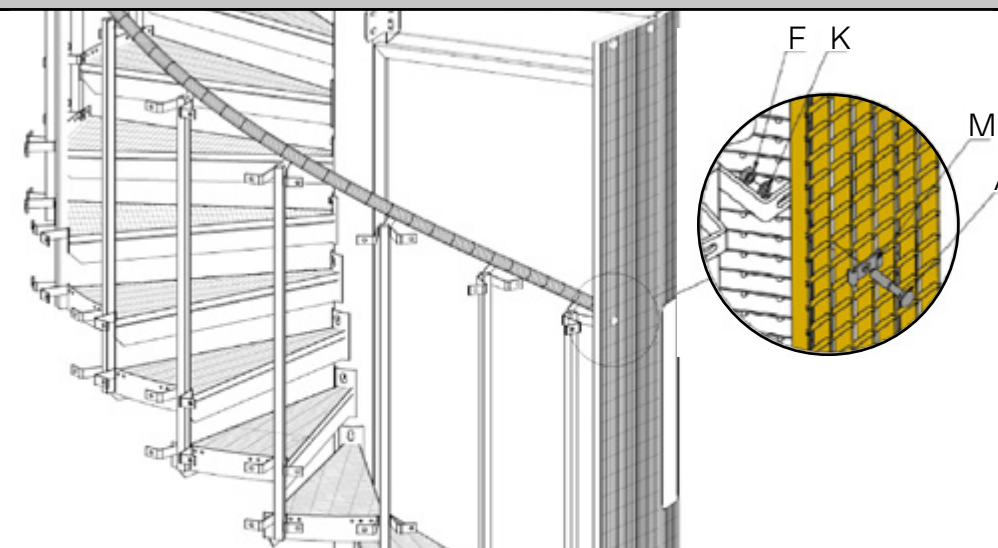

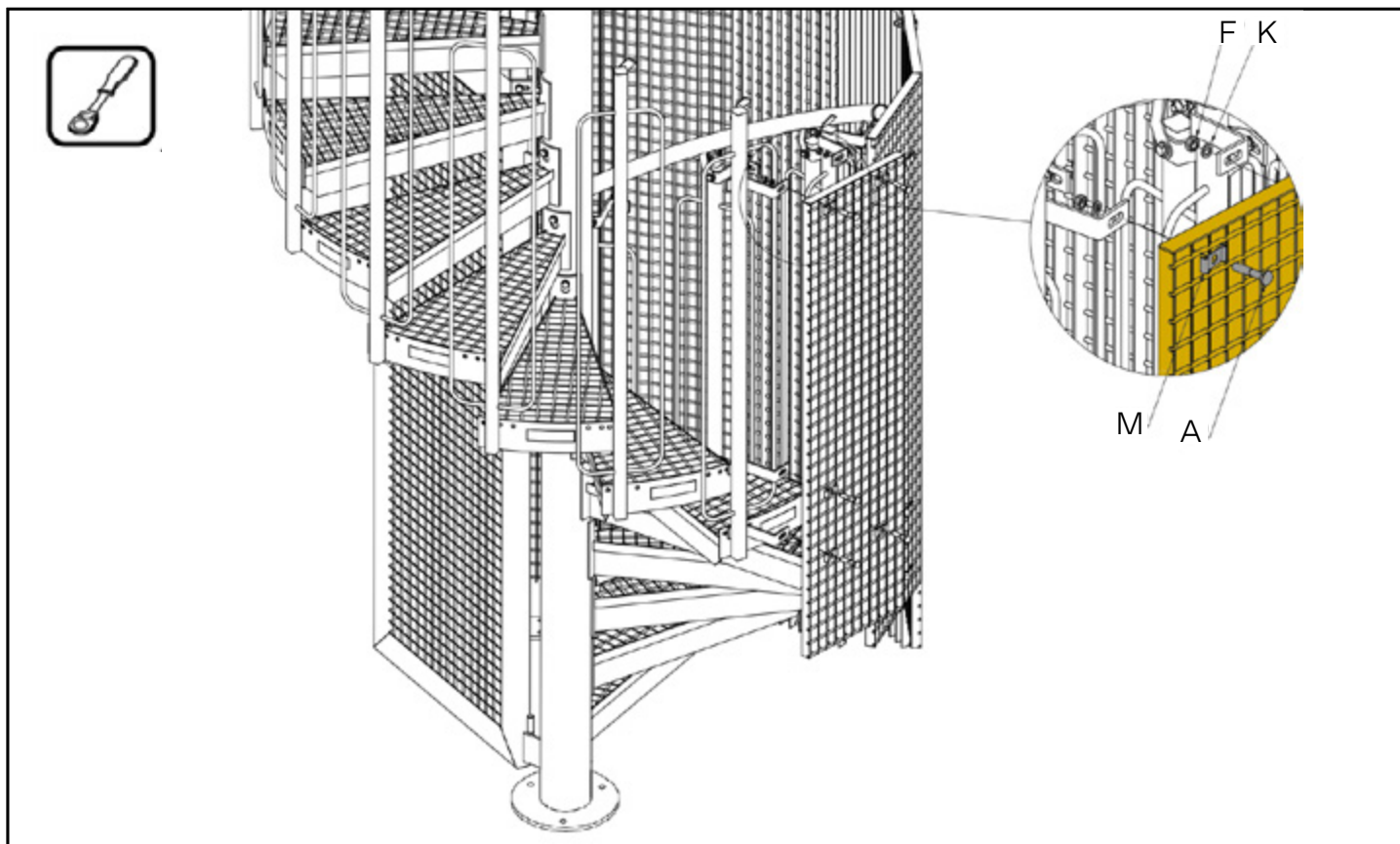

Join upper grating parts together using L-4 connectors.
 A – Bolt M10x50; M – grating fixing (top part) G-11; K – Washer 10, F – Nut M10

